



342 N. Co. Rd. 400 East
Valparaiso, IN 46383
219-464-8818 • Fax 219-462-7985
www.heatwagon.com

Installation and Maintenance Manual

Please retain this manual for future reference.

1801

**Construction
Heater**

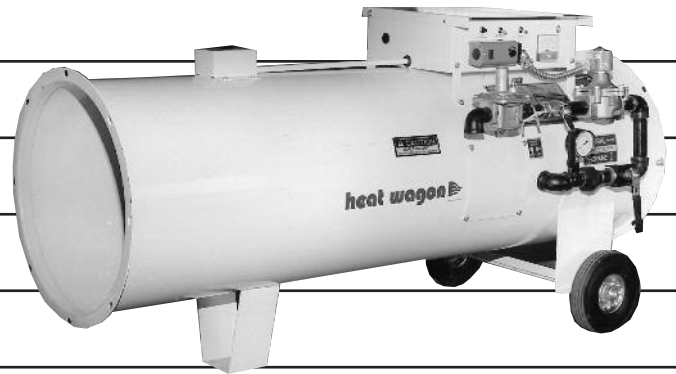

For your safety: Do not use this heater in a space where gasoline or other liquids having flammable vapors are stored.

IMPORTANT INFORMATION! READ FIRST

The heater is designed for use as a construction heater under ANSI Z83.7a-1993. The primary purpose of construction heaters is to provide temporary heating of buildings under construction, alteration, or repair and to provide emergency heat. Properly used, the heater provides safe, economical heating. Products of combustion are vented into the area being heated.

The heater **IS NOT** designed as an Unvented Gas Fired Room Heater under ANSI-Z21.11.2 and **SHOULD NOT** be used in the home.

ANSI A119.2(NFPA 501C)-1987 Recreational Vehicle Standard prohibits the installation or storage of LP-gas containers even temporarily inside any recreational vehicle. The standard also prohibits the use of Unvented Heaters in such vehicles.

NFPA-58 1989 STANDARD FOR THE STORAGE AND HANDLING OF LIQUEFIED PETROLEUM GASES

Use of the heater must be in accordance with this Standard and in compliance with all governing state and local codes. Storage and handling of propane gas and propane cylinders must be in accordance with NFPA 58 and all local governing codes.

We cannot anticipate every use which may be made for our heaters. **CHECK WITH YOUR LOCAL FIRE SAFETY AUTHORITY IF YOU HAVE QUESTIONS ABOUT LOCAL REGULATIONS.**

Other standards govern the use of fuel gases and heat producing products in specific applications. Your local authority can advise you about these.

FOR YOUR SAFETY

DO NOT USE THIS HEATER IN A SPACE WHERE GASOLINE OR OTHER LIQUIDS HAVING FLAMMABLE VAPORS ARE STORED OR USED.

CONSTRUCTION HEATER GENERAL HAZARD WARNING:
Failure to comply with the precautions and instructions provided with this heater, can result in death, serious bodily injury and property loss or damage from hazards of fire, explosion, burn, asphyxiation, carbon monoxide poisoning, and/or electrical shock.

Only persons who can understand and follow the instructions should use or service this heater.

If you need assistance or heater information such as an instruction manual, labels, etc. Contact your local Heat Wagon dealer or the manufacturer.

W A R N I N G

Fire, burn, inhalation, and explosion hazard. Keep solid combustibles, such as building materials, paper or cardboard, a safe distance away from the heater as recommended by the instructions. Never use the heater in spaces which do or may contain volatile or airborne combustibles, or products such as gasoline, solvents, paint thinner, dust particles or unknown chemicals.

Not for home or recreational vehicle use!

Installation and Maintenance Manual Model 180 I Construction Heater

Table of Contents:

	Page
Specifications	4
Installation	5
Proper Set Up	6
On-site Safety Problems & Operating Instructions	7
Preventative Maintenance	8
Trouble Shooting	9-12
Parts Breakdown	13-14
Wiring Diagrams	15-16

WARRANTY

All new Heat Wagon and Sure Flame heaters and fans are guaranteed against defective materials and workmanship for one (1) year from invoice date.

Warranty repairs may be made only by an authorized, trained and certified Heat Wagon dealer. Warranty repairs by other entities will not be considered. Warranty claims must include model number and serial number.

LIMITATIONS

Warrant claims for service parts (wear parts) such as spark plugs, igniters, flame rods will not be allowed. Diagnostic parts such as voltage meters and pressure gauges are not warrantable.

Evidence of improper fuel usage, fuel pressures outside of manufacturer's specification, poor fuel quality, and improper electric power, misapplication or evidence of abuse may be cause for rejection of warranty claims.

Travel time, mileage and shipping charges will not be allowed. Minor adjustments of heaters are dealers' responsibility. Defective parts must be tagged and held for possible return to the factory for 60 days from date of repair. The factory will provide a return goods authorization, (RGA) for defective parts to be returned.

No warranty will be allowed for parts not purchased from Heat Wagon.



342 N. Co. Rd. 400 East • Valparaiso, IN 46383
219-464-8818 • 888-432-8924 • Fax 800-255-7985
www.heatwagon.com

INSTALLATION

The Heat Wagon Model 1801 is a direct fired gas heater intended to be used primarily for the temporary heating of building under construction, alteration, or repair. Since all the products of combustion are released into the area being heated, it is imperative that adequate ventilation is provided. The flow of supply air and combustion gases must not be obstructed in any way. Do not use the heater with ductwork as this will restrict the flow supply air.

1. The heater is designed for indoor or outdoor installation in a horizontal position. Allow the following clearances from any combustible material or fuel containers.

Front Outlet:	10 feet	Sides:	2 feet
Intake:	1.5 feet	Top:	4 feet

Also make sure that no flammable vapors are present in the space where the heaters is being used.

2. The heater should be inspected before each use, and at least annually by a qualified service person.

3. The hose assembly must be inspected prior to each use of the heater. If it is evident that there is excessive abrasion or wear, or the hose is cut, it must be replaced prior to the heater being put into operation. The replacement hose assembly shall be that specified by the manufacturer. See parts list.

4. When connecting the heater to a natural gas or propane supply line ensure that the pressure at the heater inlet is within the specified range. Excessive pressure (over 5 psig) will damage the controls and void the warranty.

5. Connect the hose assembly to the heater gas inlet elbow. The elbow has a 1" female NPT thread. The optional hose assembly is supplied with a swivel connector to avoid kinking or twisting the hose for distances under 25 feet. Use a minimum inside diameter of 1/2" on LP or 3/4" on natural gas installations. Ensure that the hose assembly is protected from traffic, building materials, and contact with hot surfaces.

6. After installation, check hose assembly for gas leaks by applying a soap and water solution to each connection.

7. Connect the heater to an adequate 115 volt electrical supply as specified on the rating plate. For protection against shock hazard the supply cord should be plugged directly into a properly grounded three-prong receptacle.

8. Replacement parts are available from any Heat Wagon distributor or by calling 1-888-432-8924 for parts information.

INSTALLATION USING A PROPANE SUPPLY TANK(S)

- 1) When installing the heater for use with propane gas, set the gas selector to "Propane" and lock in position.
- 2) The propane supply system must be set up for vapor withdrawal from the operating tank(s). Liquid Propane can cause the heater to overfire and will damage valve train components.
- 3) The heater must be located at least 6 ft from any LP-Gas container, and not directed toward any LP-Gas container within 20 ft.
- 4)

<u>Minimum Tank Size</u>	<u>Outdoor Temperature</u>
500 Gal.	Above +25°F
1000 Gal.	+25°F to + 10° F
2 x 1000 Gal.	Below +10°F
- 5) The installation must conform with local codes, or in the absence of local codes, with the Standard for Storage and Handling of Liquefied Petroleum Gasses ANSI/NFPA 58.
- 6) Turn off the propane supply valve at the tank(s) when the heater is not in use.
- 7) When the heater is to be stored indoors the propane tank(s) must be disconnected from the heater and the tank(s) stored in accordance with Chapter 5 of the above National Standard.

COMMON INSTALLATION AND OPERATIONAL PROBLEMS

- 1) **LOW VOLTAGE AT THE HEATER**
This is one of the most common problems and is usually the result of the supply cord having too small a wire gauge for its length, or low voltage at the power source. Low voltage results in the motor overheating, burnt relay contacts, or a relay that will not make contact. Check voltmeter on heater before start-up.
- 2) **SUPPLY LINE TOO SMALL**
Minimum Size: 1/2" for LP, 1" for Natural Gas.
- 3) **INSUFFICIENT VAPORIZATION AT SUPPLY**
Normally caused by undersized supply tank.
- 4) **IMPROPER GAS SUPPLY PRESSURE**
Usually a result of propane supply pressure being too high because of improper or lack of regulation or too low of natural gas pressure at meter.
- 5) **DIRTY GAS SUPPLY**
Dirty gas can cause strainers to plug or form a build-up in the burner orifice.
- 6) **LACK OF PREVENTIVE MAINTENANCE**
Heaters must be cleaned as required, especially when used in a dirty environment.
- 7) **IMPROPER SUPPLY OF FRESH AIR**
It is strongly recommended that the intake air of the heater be taken from outside the enclosed area. This provides a slight pressurization and prevents any problems associated with recirculation of products of combustion.

ON-SITE SAFETY PROBLEMS

1) SHORTING OUT OF DEFECTIVE COMPONENTS

This is a very common problem which saves short term expense at the risk of a large future cost. Any heaters found in this condition should be removed immediately.

2) IMPROPER ENCLOSURES

When heaters are installed partially to the outside for fresh air intake, strict adherence must be made to the minimum clearance to combustibles given on the instruction plate. Wood framing around a heater can cause a safety hazard.

3) SUPPLYING LIQUID PROPANE TO HEATER

This problem has occurred upon initial start-up. To minimize the damage, shut off the gas supply and let the heater run until all of the liquid in the lines had been consumed.

OPERATING INSTRUCTIONS

- 1) Set the **gas selector valve** for fuel being used. Check for proper gas pressure.
- 2) Open **manual shut-off valve** on heater.
- 3) Connect power supply (115 volt). Check voltmeter to confirm full voltage.
- 4) Slowly open shut-off valve at gas meter or propane tank. Check for leaks.
- 5) Set **fan** and **burner switches** to "on" position.
- 6) Set **thermostat** for desired room temperature.
- 7) To stop, turn **thermostat** down or turn **fan switch** "off".
(Burner will turn off; after 5 seconds fan will turn off.)
- 8) Close **manual shut-off valve** on heater.

NOTE: If the heater will be shut down over night, close valve at fuel supply first and burn all gas out of line.

The appliance area should be kept clear and free from combustible materials, gasoline, and other flammable vapors and liquids.

Ensure that the flow of supply air and combustion gases is not obstructed.

The installation and operation of the heater shall comply with the code requirements specified by the authorities having jurisdiction.

General criteria for the use of construction heaters may be found in the applicable sections of American National Standard A-10.10-1987, Safety Requirements for Temporary and Portable Space Heating Devices and Equipment Used in the construction industry.

THE INSTALLATION AND MAINTENANCE OF THE HEATER MUST BE ACCOMPLISHED BY A QUALIFIED SERVICE PERSON.

PREVENTIVE MAINTENANCE

Heat Wagon Construction Heaters are built to withstand the rigors of operating on construction sites, for mining applications, and a multitude of other locations where heaters are used. To maintain the reliable performance required it is necessary to do a certain amount of regular maintenance.

A) VISUAL CHECKS

The following items should be checked for excessive wear or damage:

- 1) Wheels (if installed)
- 2) Cords and Connectors
- 3) Wiring and Conduit
- 4) Heater shell (including heat shield) and control box

It is recommended that units purchased as spares be rotated periodically, so that each unit will be placed in operation at least once every 90 days.

B) BURNER

Igniter/Flame: Clean with soap and water or solvent on a routine basis.
Sensor Assembly: Any build up on burner should also be removed at this time.
Make sure all burner ports are open.

Ground Wire: Ensure that the ground wire is secured to the burner. This is necessary for the flame detection system to operate.

C) AIR SWITCH

Check for dirt build up inside air tube. Remove tube before cleaning with compressed air. Tube inlet must face fan blade.

D) CONTROL BOX

The inside of the control box should be cleaned using a dry cloth or by blowing compressed air. Tube inlet must face fan blade.

E) MOTOR

The electric motor on the 1801 Heater is fitted with sealed bearings and no oiling required. Keep the motor clean by blowing or wiping off dust or dirt in order to prevent the motor from over heating.

F) FAN

Check for dust or dirt build up on fan blades. Check the tightness of the set screws and run the heater to check for fan vibration.

G) HEATER HOUSING

Clean with soap and water. Pay attention to decals and labels so that they remain legible.

TROUBLE SHOOTING

Note: In order to make these checks a voltmeter is required. The motor and the control circuit is 120 volt. Use extreme caution when checking voltage. With no flame present at igniter, the flame control will try for ignition for 7 seconds after it is energized. After 15 second delay, the flame control will retry for another 7 seconds to establish flame.

I) Problem: Fan motor will not start.

1) Sequence:

With fan and burner switches "on", the thermostat is turned up to start the heater. Power is sent from the thermostat, through the fan toggle switch and energizes the fan delay timer. The timer sends power to the motor (power) relay holding coil which then closes the motor relay contacts to send power to the fan motor.

2) Possible Causes:

- A) No power at plug or bad ground.
- B) Blown 20 amp fuse.
- C) Defective thermostat or fan switch.
- D) Defective motor relay coil.
- E) Defective 3 amp circuit breaker or fuse.
- F) Defective fan delay timer.
- G) Motor overload tripped or defective motor.
- H) Wire from motor relay to motor burnt or broken

3) Check:

- A) For reading at voltmeter on control panel (minimum 105 volts).
- B) For 120 volt at 20 amp fuse.
- C) For 120 volt at L1 and L2 of motor relay.
- D) That thermostat is set to call for heat and fan toggle switch is in the "on" (up) position.
- E) For 120 volt at motor relay coil.
- F) For fan blade interference.
- G) If there is power to the motor, the overload in the motor may have tripped. Wait 30-40 minutes for overload to reset. If the motor does not start this time, the motor must be replaced. The overload must be manually reset by pushing in the reset button located on wiring junction box on the motor.

II) Problem: No spark at igniter

1) Sequence:

Just before the fan reaches full speed, the air flow switch closes from the air pressure produced by the fan and turns on the indicator lamp. At the same time power is sent to the flame (ignition) control where a 15 second delay occurs before a high voltage spark is sent to the igniter.

2) Possible Causes:

- A) Worn out or broken igniter.
- B) Ignition wires burnt or broken or shorted to ground.
- C) Defective flame control.
- D) Defective burner switch.
- E) Air flow switch defective or out of adjustment.

3) Check:

- A) For 120 volt at air flow switch terminal #2 (yellow) and neutral (white wires).
- B) For 120 volt at air flow switch term. #3(red) and neutral wires.
- C) For 120 volt at terminals L1 and L2 of fenwal flame control.

III) Problem: Spark but no flame.

1) Sequence:

At the same time that spark is sent to the igniter, the flame control sends 120 volts to the coil of the gas solenoid valve(s). This allows gas into the burner to be ignited by the spark at the igniter.

2) Possible Causes:

- A) Manual gas valve closed at heater or at fuel source.
- B) Fuel line blockage or restriction.
- C) Defective flame control board.
- D) High limit switch tripped or defective.
- E) Defective gas solenoid valve coil.
- F) Incorrect pressure regulator installed in fuel line.
- G) Plugged burner ports.

3) Check:

- A) For proper reading on pressure gauge.
- B) Fuel line blockage or restriction.
- C) Defective flame control board.
- D) High limit switch tripped or defective.
- E) Defective gas solenoid valve coil.
- F) Incorrect pressure regulator installed in fuel line.
- G) Plugged burner ports.

IV) Problem: Flame is on for only a few seconds, and fan continues to run.

1) Sequence:

When flame is established, it is sensed by the long electrode of the igniter. The flame will stay on as long as the proper current is produced by the flame and the thermostat calls for heat.

2) Possible Cause:

- A) Flame sensing wire (E2 terminal at flame control) broken or burnt.
- B) Worn or damaged igniter assembly.
- C) Heater and/or burner not properly grounded.
- D) Incorrect polarity at heater power supply.
- E) Flame is beyond sensing electrode of igniter.

3) Check:

- A) For reversed polarity at power cord. There should be 120 volts between the black (hot) and the green (ground) wires. There should be 0 volts between the white (neutral) and the green (ground) wires.
- B) For proper grounding of the heater. If there is 120 volts between the black and the white wires of the power cord, and there is low or zero volts between the black and green (ground) wires, the poor ground must be corrected for proper burner operation. Or the black & white wires are reversed at receptical.
- C) Condition of igniter assembly. Replace or clean if there is carbon deposits.
- D) That burner is not overfiring. Gauge readings are: 7.0" w.c. natural and 3.0" w.c. propane.

V) Problem: Small burner flame.

1) Possible Causes:

- A) Partially plugged burner ports.
- B) Restricted gas flow in the heater pipe train.
- C) Inlet screen dirty at gas connection of heater pipe train.
- D) Too low of supply pressure.
- E) Too small of a supply line.

2) Check:

- A) The manifold gauge for proper reading. A low reading indicates a restriction at the regulator or solenoid valve(s) on the heater.
- B) The supply pressure to the heater by installing a high pressure gauge (psi) at the heater gas inlet. Turn gas on at source, and not gauge reading first with heater off, then with heater on. If gauge reading drops to zero with heater running, the restriction is at the fuel source or in the supply line. If the gauge reading does not drop, the restriction is in the heater pipe train.

VI) Problem: Fan continues to run after thermostat turns off burner

1) Sequence:

When thermostat setting is reached or fan switch is turned off, the burner will shut off. The fan will shut off after a 5-7 second delay.

2) Possible Causes:

- A) Defective fan delay timer.
- B) Motor (power) relay stuck closed.

3) Check:

- A) For burnt or welded motor relay contacts and free travel of relay armature

VII) Problem: Burner shuts off after several minutes, fan continuous to run.

1) Possible Causes:

- A) High limit switch defective.
- B) Air flow restricted at heater inlet.
- C) Air flow restricted at heater outlet.
- D) Burner is over firing.

2) Check:

- A) Reading on manifold gauge. If reading is within specifications, replace limit switch. If reading is high, adjust pressure regulator or replace regulator if outlet pressure cannot be reduced.

VIII) Problem: Erratic burner operation (Burner shuts off, after 15-20 seconds, burner comes on) Light flashes on and off.

1) Possible Causes:

- A) Air flow switch sensitivity too high.
- B) Air flow switch tube partially plugged or turned.
- C) Wind gusts causing air switch to fluctuate.

2) Check:

- A) Air flow switch setting is typically .4" to .6" w.c.. Tube must be pointing at fan blade and be free of dirt.
- B) Light on control box should glow continuously during heater operation. When light is off air flow switch is open.
- C) Strong wind gusts can be deflected with a plywood wind break at inlet end of heater.

IX) Problem: Excessive products of combustion (strong odor) and/or yellow flame.

1) Possible Causes:

- A) Heavy ends (oil) from propane collected in heater pipe train and burner ports
- B) Contaminated fuel line or fuel source
- C) Lack of fresh air to burner
- D) Polluted air entering combustion chamber
- E) Improper air/fuel mixture

2) Check:

- A) For oil residue inside burner and heater housing. Pipe train and burner must be cleaned out and a drip leg installed if oil is present. Alert propane supplier of this problem, so corrective action can be taken.
- B) Inspect fuel supply lines for dirt, oil, etc.
- C) That heated air is not being recirculated through heater. Fresh air for combustion is required for maximum efficiency and heated air quality.
- D) For damage to the heater housing and burner air baffles. Any alteration can cause increased levels of combustion by-products.
- E) Engine exhaust, paint fumes, drywall dust, etc. will have an adverse effect on heated air quality.

MODEL 1801 PIPE TRAIN AND BURNER BREAKDOWN

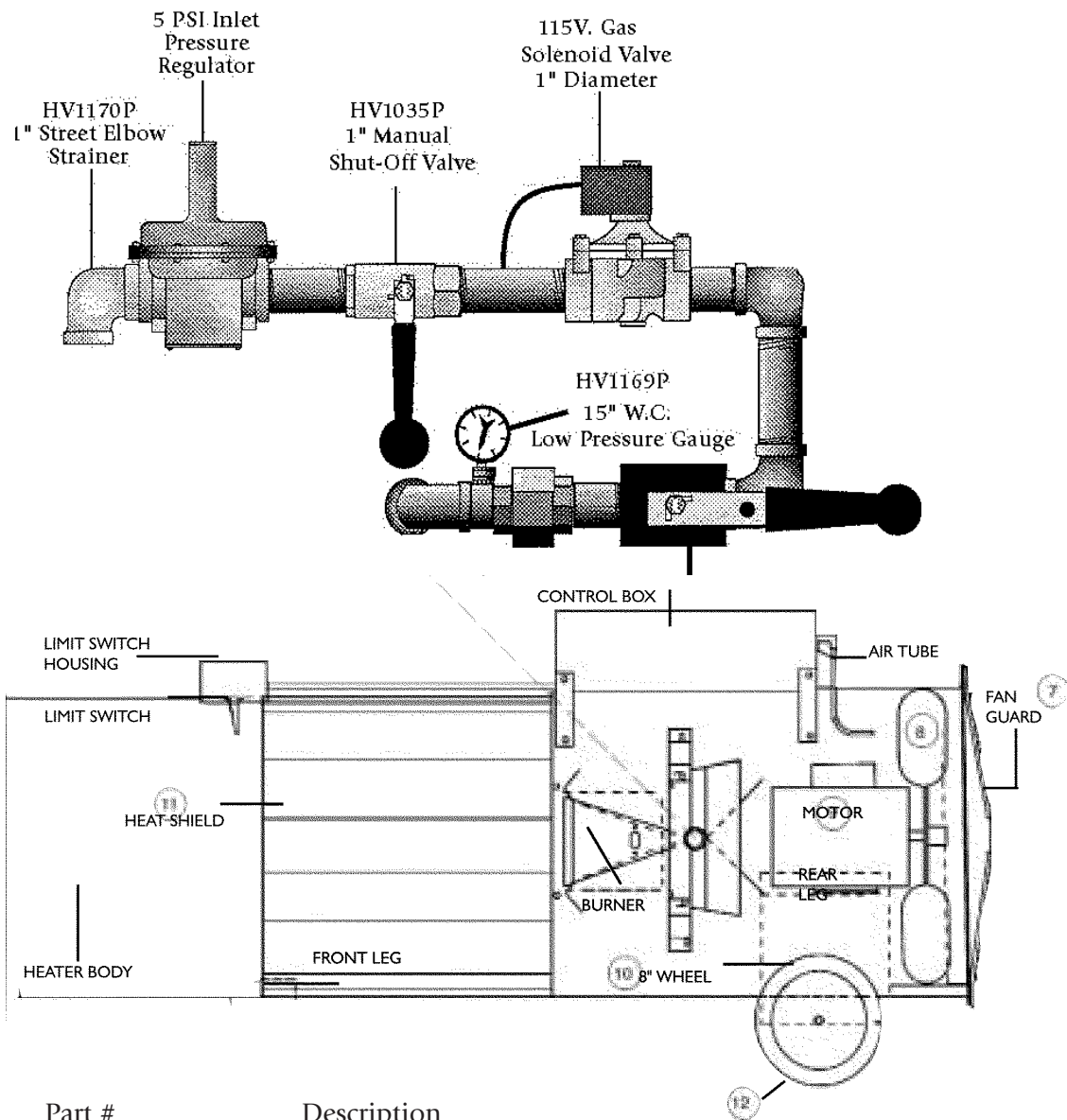

<u>Item #</u>	<u>Part #</u>	<u>Description</u>
1	HWP HV1170	1" Street Elbow Strainer
2	HWP HV1162	5 PSI Inlet Pressure Regulator
3	HWP HV1035	1" Manual Shut-Off Valve
4	HWP HV1032	115 V. Gas Solenoid Valve 1" Dia.
5	HWP HV1169	15" W.C. Low Pressure Gauge
6	HWP HV1160	1" Locking Gas Selector Valve
7	HWP HG1167	Fan Guard
8	HWP HP1161	Fan Blade 18" Diameter
9	HWP HM1166	1 HP TEAO Motor
10	HWP HB1171	Burner Assembly - 1801
11	HWP HB1177	Heat Shield
12	HWP HW1164	Wheel : 8" Dia. x 1.75 x 1/2" Hub
<u>Not Shown</u>		
	DEC DK1801	Decal Kit for Model 1801
	HWP HV1032C	Coil Cover
	HWP HV1032RK	Rebuild Kit for HV1032
	HWP HW1164B	Axle

MODEL 1801 CONTROLS BREAKDOWN

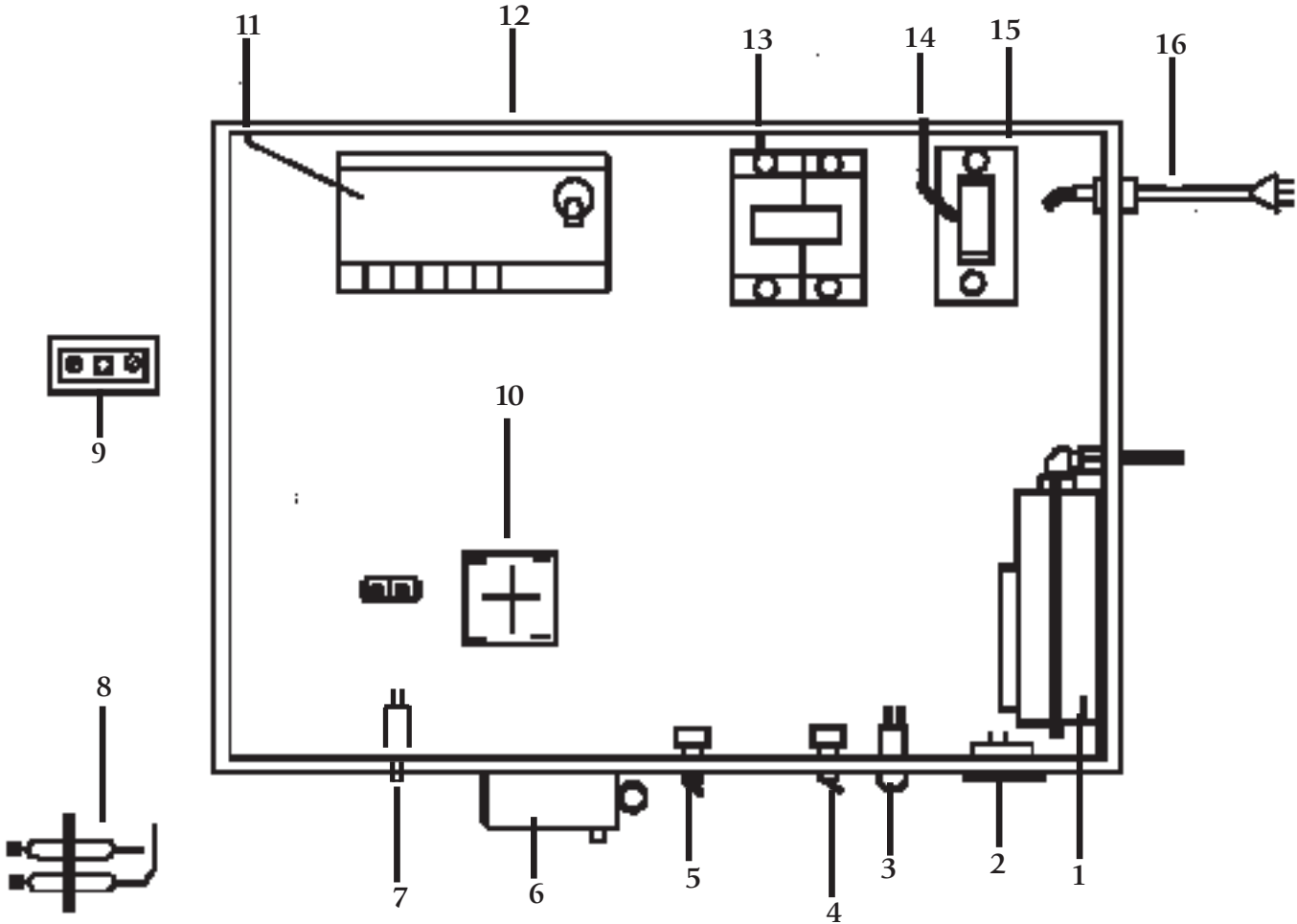

<u>Item #</u>	<u>Part #</u>	<u>Description</u>
1	HWP HC1010	Airflow Switch
2	SFP 5989	Supply Voltage Meter (0 - 150)
3	SFP 2505	Indicator Light
4	HWP HC1011	Fan On/Off Switch
5	HWP HC1011	Burner On/Off Switch
6	SFP 2453	Thermostat (35-95°)
7	HWP HC1019B	3 amp. Circuit Breaker
8	HWP HC1004B	Electrode Assembly
9	HWP HC1163	High Limit Switch
10	SFP 5988	Fan Delay Timer
11	HWP HC1001C	Ignition Control Board w/ Time Delay
12	HWP HC1069A	Control Box w/ Cover
13	SFP 2436	Motor Contactor
14	HWP HC1115	20 AMP. Fuse (SC - 20)
15	HWP HC1122	Fuse Block
16	HWP HC1020	Power Cord

Not Shown

HWP 1069B

Control Box Lid

MODEL 1801 WIRING DIAGRAM

HEAT WAGON INC.		SEQUENCE	MACHINE	REVISED
PART NO.	1801	X	X	DATE
NAME	WIRING DIAGRAM			BY
MATERIAL	AS SHOWN			
	SCALE 1/2			
	OLD DRAWING NO.			
	DATE			
	DRAWN BY IJV ∞ DAR			

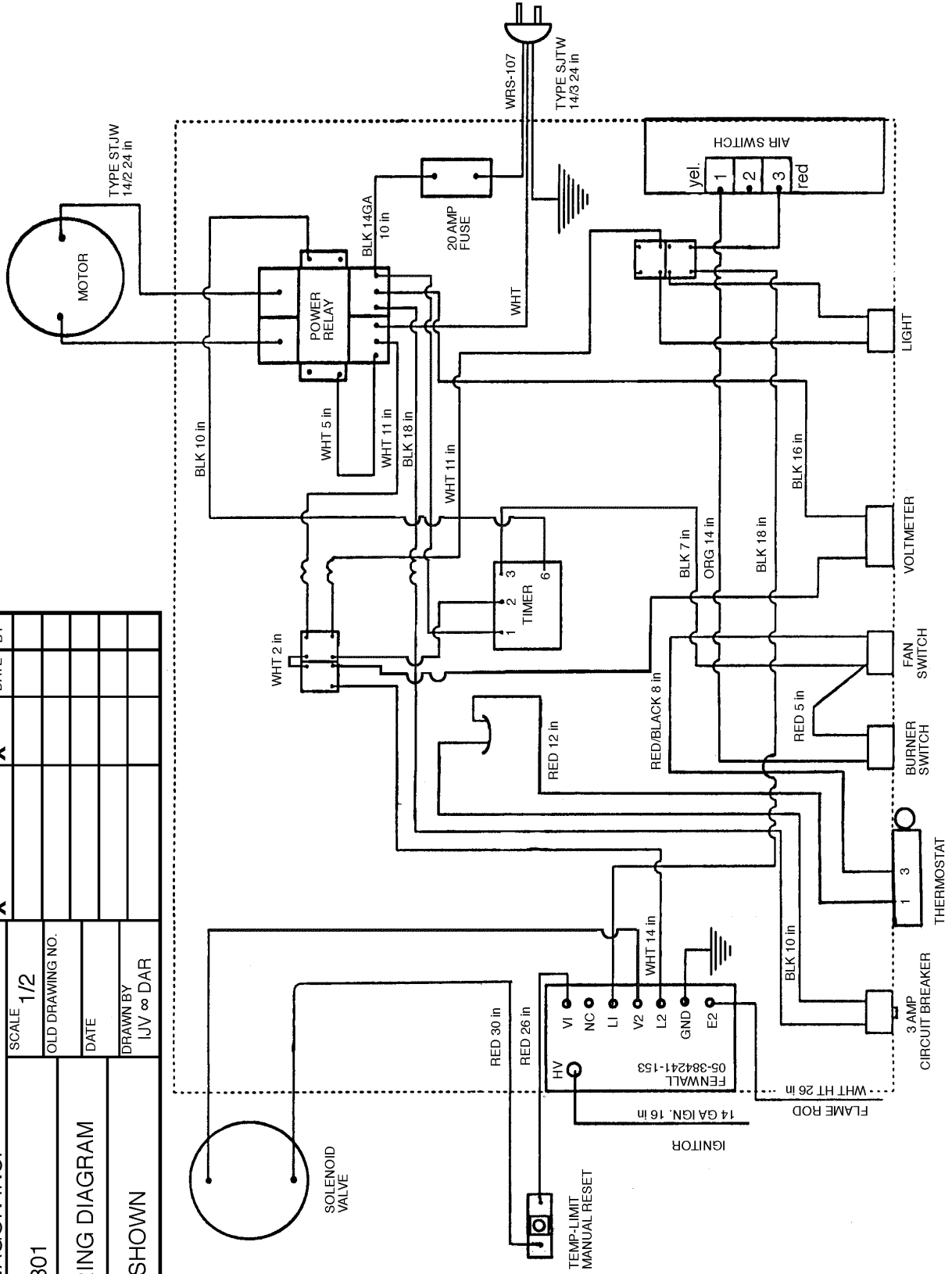

MODEL 1801 WIRING DIAGRAM

