



342 N. Co. Rd. 400 East  
Valparaiso, IN 46383  
219-464-8818 • Fax 219-462-7985  
[www.heatwagon.com](http://www.heatwagon.com)

## Installation and Maintenance Manual

Please retain this manual for future reference.

# *S1505*

*Construction  
Heater*



*For your safety: Do not use this heater in a space where gasoline or other liquids having flammable vapors are stored.*

# **IMPORTANT INFORMATION! READ FIRST**

The heater is designed for use as a construction heater under ANSI Z83.7a-1993. The primary purpose of construction heaters is to provide temporary heating of buildings under construction, alteration, or repair and to provide emergency heat. Properly used, the heater provides safe, economical heating. Products of combustion are vented into the area being heated.

The heater **IS NOT** designed as an Unvented Gas Fired Room Heater under ANSI-Z21.11.2 and **SHOULD NOT** be used in the home.

ANSI A119.2(NFPA 501C)-1987 Recreational Vehicle Standard prohibits the installation or storage of LP-gas containers even temporarily inside any recreational vehicle. The standard also prohibits the use of Unvented Heaters in such vehicles.

## **NFPA-58 1989 STANDARD FOR THE STORAGE AND HANDLING OF LIQUEFIED PETROLEUM GASES**

Use of the heater must be in accordance with this Standard and in compliance with all governing state and local codes. Storage and handling of propane gas and propane cylinders must be in accordance with NFPA 58 and all local governing codes.

We cannot anticipate every use which may be made for our heaters. **CHECK WITH YOUR LOCAL FIRE SAFETY AUTHORITY IF YOU HAVE QUESTIONS ABOUT LOCAL REGULATIONS.**

Other standards govern the use of fuel gases and heat producing products in specific applications. Your local authority can advise you about these.

## **FOR YOUR SAFETY**

**DO NOT USE THIS HEATER IN A SPACE WHERE GASOLINE OR OTHER LIQUIDS HAVING FLAMMABLE VAPORS ARE STORED OR USED.**

**CONSTRUCTION HEATER GENERAL HAZARD WARNING:**  
Failure to comply with the precautions and instructions provided with this heater, can result in death, serious bodily injury and property loss or damage from hazards of fire, explosion, burn, asphyxiation, carbon monoxide poisoning, and/or electrical shock.

Only persons who can understand and follow the instructions should use or service this heater.

If you need assistance or heater information such as an instruction manual, labels, etc., contact your local Heat Wagon dealer or the manufacturer.

## **W A R N I N G**

Fire, burn, inhalation, and explosion hazard. Keep solid combustibles, such as building materials, paper or cardboard, a safe distance away from the heater as recommended by the instructions. Never use the heater in spaces which do or may contain volatile or airborne combustibles, or products such as gasoline, solvents, paint thinner, dust particles or unknown chemicals.

**Not for home or recreational vehicle use!**

# Installation and Maintenance Manual Model S1505 Construction Heater

## Table of Contents:

	<b>Page</b>
Specifications .....	4
Installation .....	5
Operating Instructions .....	6
Common Installation & Operational Problems .....	7
Preventive Maintenance .....	8
Troubleshooting .....	9-10
Parts Breakdown .....	11
Wiring Diagrams .....	12-14
Fuel Sizing Charts .....	15-16

## WARRANTY

All new Heat Wagon and Sure Flame heaters and fans are guaranteed against defective materials and workmanship for one (1) year from invoice date.

Warranty repairs may be made only by an authorized, trained and certified Heat Wagon dealer. Warranty repairs by other entities will not be considered. Warranty claims must include model number and serial number.

## LIMITATIONS

Warrant claims for service parts (wear parts) such as spark plugs, igniters, flame rods will not be allowed. Diagnostic parts such as voltage meters and pressure gauges are not warrantable.

Evidence of improper fuel usage, fuel pressures outside of manufacturer's specification, poor fuel quality, and improper electric power, misapplication or evidence of abuse may be cause for rejection of warranty claims.

Travel time, mileage and shipping charges will not be allowed. Minor adjustments of heaters are dealers' responsibility. Defective parts must be tagged and held for possible return to the factory for 60 days from date of repair. The factory will provide a return goods authorization, (RGA) for defective parts to be returned.

No warranty will be allowed for parts not purchased from Heat Wagon.



342 N. Co. Rd. 400 East • Valparaiso, IN 46383  
219-464-8818 • 888-432-8924 • Fax 800-255-7985  
[www.heatwagon.com](http://www.heatwagon.com)

## SPECIFICATIONS

### **Model No. S1505**

Designed to ANSI Z83.7-1991	Construction Heater
Gases:	Natural or Propane
Capacity:	1,500,000 Btu/h maximum 850,000 Btu/h minimum
Orifice Size:	41 DMS (x46)
Blower:	7,000 CFM
Electrical Rating:	115V, 60Hz, 20 amps, single phase
Min. Temperature Rating	-40°F

Gas Supply:	Inlet Pressure		Manifold Pressure	
	Max W.C.	Min W.C.	Max W.C.	Min W.C.
Propane	14"	9"	2.7"	.75"
Natural Gas	14"	9"	7.2"	2.0"

(Minimum inlet pressure is for purpose of input adjustment)

### **DESIGN RELATED ADDITIONAL SAFETY FEATURES**

1. **Locking position for LPG on gas selector lever:** Units used with LPG while the gas selector valve is positioned for Natural Gas will throw significantly more heat than the rated Btu/h. This is definitely a safety hazard.
2. **Low skin temperature:** Sure Flame Heaters are designed to have a low skin temperature. This provides added safety in the workplace.
3. **Durable Construction:** The Model S1505 used a stainless steel burner for long life and consistent performance.

In order to maintain the highly efficient combustion of the Sure Flame Heater, the combustion chamber must remain as manufactured. Any change or distortion could alter the fuel/air mixture and create unwanted gases.

## INSTALLATION

The Sure Flame Model S1505 is a direct fired gas heater intended to be used primarily for the temporary heating of building under construction, alteration, or repair. Since all the products of combustion are released into the area being heated, it is imperative that adequate ventilation is provided. The flow of supply air and combustion gases must not be obstructed in any way.

1. The heater is designed for indoor or outdoor installation in a horizontal position. Allow the following clearances from any combustible material or fuel containers.

Front Outlet:	20 feet	Sides:	2 feet
Intake:	2 feet	Top:	4 feet

Front outlet must not be directed at any LP-Gas container within 20 feet.

Also make sure that no flammable vapors are present in the space where the heater is being used.

2. When connecting the heater to a natural gas or propane supply line ensure that the pressure at the heater inlet is within specified range. Please refer to Propane and Natural Gas installation sections on Page 7. Excessive pressure (over 1/2" psig) will damage the controls and void the warranty.
3. Visually inspect the hose assembly and ensure that it is protected from traffic, building materials, and contact with hot surfaces. If it is evident that there is excessive abrasion or wear, or the hose is cut, it must be replaced.
4. After installation, check the hose assembly for gas leaks by applying a water and soap solution to each connection.
5. Connect the heater to an adequate 115 volt electrical supply and in compliance with the National Electrical Code ANSI/NFPA 7.0. For protection against shock hazard the supply cord should be plugged directly into a properly grounded three-prong receptacle.

**EXTENSION CORDS:**

Properly Wired and Grounded

Use #14 wire up to 100'

Use #12 wire up to 200'

Use #10 wire up to 300'

6. In all applications install the heater in such manner it is not directly exposed to water spray, rain and or dripping water.

## Installation using a propane supply cylinder

1. When installing the heater for use with propane gas, set the gas selector valve to “Propane” and lock in position.
2. The supply container **must** be equipped with an LP Gas Regulator that complies with ANSI/UL 144 Standard for Pressure Regulating Valves for LP Gas. Another regulator must be installed on the heater to reduce the pressure from this regulator down to a maximum inlet pressure of 1/2 psi.
3. Arrange the cylinder supply system to provide for vapor withdrawal from the operating cylinder. Supplying liquid propane to the heater is dangerous and will damage the components.
4. Ensure that for the surrounding temperature the size and capacity of the propane supply cylinder is adequate to provide the rated Btu/h input to the heater.
5. Turn off the propane supply cylinder when the heater is not in use.
6. The installation must conform with local codes, or in the absence of local codes, with the Standard for the Storage and Handling of Liquefied Petroleum Gases. ANSI/NFPA 58-1989.
7. When the heater is to be stored indoors the connection between the propane cylinder and the heater must be disconnected and the cylinder removed from the heater and stored in accordance with Chapter 5 of the above national standard.

## Installation for Natural Gas Applications

1. When installing the heater for use with Natural Gas, set the selector valve to the “Natural” position.
2. A regulator must be installed on the heater only if the line pressure to the heater is greater than 1/2 psi.
3. The installation of this heater to a natural gas supply must conform with all applicable local codes, or in the absence of local codes, with the National Fuel Gas Code, ANSI Z223.1/NFPA 54.

## Operating Instructions

1. Set the **GAS SELECTOR VALVE** to gas being used. The conversion shall be done by the owner or lessor of the equipment.

NOTE: When using Propane Gas the Selector Valve **MUST** be locked in the “ON” position.

2. Ensure **MANUAL VALVE** (valve nearest the burner) is in the “ON” position.
3. Connect power - 115 volt supply
4. Open gas supply.
5. Push **START** button and release.
6. Set thermostat to desired temperature.
7. To stop, turn gas off.

The appliance area should be kept clear and free from combustible materials, gasoline, and other flammable vapors and liquids.

Ensure that the flow of supply air and combustion gases is not obstructed.

The installation and operation of the heater shall comply with the code requirements specified by the authorities having jurisdiction.

General criteria for the use of construction heaters may be found in the applicable sections of American National Standard A-10.10-1987, Safety Requirements for Temporary and Portable Space Heating Devices and Equipment Used in the Construction Industry.

**Installation and maintenance of the heater must be accomplished by a qualified service person.**



## Common Installation & Operational Problems

1. **Low Voltage**- This is one of the most common problems and is usually the result of the supply cord having too small a wire gauge for its length. Low voltage results in the motor overheating, burnt relay contacts, or a relay that will not make contact.
2. **Supply line undersized. (Refer to page 15-16)**
3. **Insufficient Vaporization at Supply**- Normally caused by undersized supply tank.
4. **Improper Gas Supply Pressure** - Usually a result of supply pressure being too high because of improper or no regulation.
5. **Dirty Gas Supply** - Dirty gas can cause strainers to plug or form a buildup in the burner orifice.
6. **Lack of Preventative Maintenance** - Heaters must be cleaned as required, especially when used in a dirty environment.
7. **Improper Supply of Fresh Air** - It is normally recommended that the intake air of the heater be taken from outside the enclosed area. This provides a slight pressurization and prevents any problems associated with recirculation.

## On-Site Safety Problems

1. **Shorting out of defective components**  
This is a very common problem which saves short term expense at the risk of a large future cost. Any heaters found in this condition should be removed immediately.
2. **Improper enclosures**  
When heaters are installed partially to the outside for fresh air intake, strict adherence must be made to the minimum clearance to combustibles given on the instruction plate. Wood framing around a heater is a request for trouble.
3. **Supplying liquid propane to heater**  
This problem has occurred from time to time. To minimize the damage, shut off the gas supply and let the heater run until all of the liquid in the lines has been burnt.

# Safety Features

Servicing of Sure Flame Construction Heaters normally involves one of several built-in safety features. The Model S1505 incorporates devices to detect the following:

1. LOSS OF FLAME                      Gas supply is shut off if flame is lost to prevent raw gas from leaving the heater.
2. OVERHEATING                      a) Thermal overload protection in the motor  
   b) High temperature limit switch in the combustion chamber
3. LOSS OF POWER                      Total shutdown with manual reset required. Any one of the safety devices will create a loss of power situation.
4. BLOCKED AIR SUPPLY              A switch detects the differential pressure in the combustion chamber and shuts down when insufficient

## Preventative Maintenance

Sure Flame construction heaters are built to withstand the rigors of operating on construction sites, for mining application, and multitude of other locations where heaters are used. To maintain reliable performance required it is necessary to do a certain amount of regular maintenance.

### A. Visual Checks

The following items should be checked for excessive wear or damage:

- 1) Wheels
- 2) Cords and Connectors
- 3) Wiring and Conduit
- 4) Heater shell (including heat shield) and Control Box.

### B. Burner

Flame rod and insulator -              Clean with soap and water or solvent on a routine basis. Any build up on burner should also be removed at this time.

Spark Plug-                                      Clean with solvent and check spark gap, approx. .070 to .085.

### C. Control Box

The inside of the control box should be cleaned using a dry cloth or by blowing compressed air. **Do not** use any liquid or aerosol spray cleaners. Also check that all electrical connections are snug and tight.

### D. Motor

The electric motor on the S1505 Heater is fitted with sealed bearings and no oiling is required. Keep the motor clean by blowing or wiping off dust or dirt in order to prevent it from overheating.

### E. Fan

Check for build up on fan blades. Check the tightness of the set screw and run heater to check for fan vibration.

# Troubleshooting S1505

In order to make these checks an AC Voltmeter is required. Both the control circuit and the motor voltage is 115VAC. Use extreme caution when checking voltage.

1. Push start button and hold for 2 to 3 seconds.
2. Motor relay and control relay #1 to close simultaneously
  - 1) If motor relay does not close check:
    - a) If there is power between the coil terminals of the motor starting relay is faulty.
    - b) If there is no power between these two terminals then proceed to check delay timer.
    - c) If there is power between terminals 1 & 2 and 2 & 3, but no power between 2 & 6, then the timer is defective.
    - d) If there is no power between terminals 2 & 3, of the timer then check the start switch.
  - 2) If control relay #1 does not close then check:
    - a) If there is power present at terminals A & B of the control relay then the control relay is defective.
    - b) If there is no power between these terminals then check the stop switch.
    - c) If there is power on the common (middle) terminal of the stop switch but no power on the NC terminal then the stop switch is defective.
3. Fan starts, if not check:
  - a) If there is power between the black and white wires inside the motor junction box (located on side of motor) then the motor may need manual resetting. Pushing the red button on the side of the junction box. If this does not correct the problem then the motor is faulty.
  - b) If there is no power at these two wire ends then check the motor relay contacts, they may need cleaning or replacing, if burnt.
4. Fan reaches full speed, airswitch closes, and white light comes on, if not check:
  - a) If there is power on only one of the airswitch terminals while motor is running, then the airswitch is staying open. First check if either the upstream or down stream airtubes are plugged.
  - b) If both are free then check alignment (tubes must be positioned parallel to the direction of airflow)
  - c) If above procedures do not correct problem, then the adjusting screw located on the side of the airswitch can be rotated counter clockwise, just enough so that the fan stays running.
5. Control relay #2 closes, if not check:
  - a) If there is power between terminals A & B of relay #2, if power is present then relay is faulty
  - b) If there is power between terminals L1 & L2 of the Fenwall module, but no power 2 sends after start-up between terminals V1 & V2 of the Fenwall, then the Fenwall module is defective.

## Troubleshooting S1505

6. Gas valves are energized, and spark is initiated:
  - 1) If gas valves do not open then check each gas valve individually
    - a) If there is power between the wires leading to the gas valve, then the gas valve is faulty
    - b) If there is no power at terminal V1 of the Fenwall module 2 seconds after start-up, but there is power at terminal L1 of the Fenwall then the Fenwall module is faulty.
    - c) If there is no power at terminal L1 of the Fenwall module then check the following components using the previously mentioned tests for the limit switch, the airswitch and control relay #2.
  - 2) If there is no spark then check:
    - a) The spark plug, gap should be at least 1/8"
    - b) If ignition wire is burnt or if it is grounding out to the heater.
    - c) If there is power at terminal L1, and no power at terminal V1 of the Fenwall then the Fenwall module is faulty.
- 7) Flame rod senses and maintains flame, if not check:
  - a) If flame rod wire is connected to flame rod and not grounding out to the heater
  - b) If flame rod wire is inserted into the correct location on the Fenwall module
  - c) The flame rod must always be screwed into the burner securely. The probe part should not be touching the burner in any way thus grounding out.
  - d) If the flame is too short and flame rod is not bright orange color, then check if there is adequate manifold gas pressure.
  - e) If above checks are all good then the Fenwall module is defective.
- 8) Set thermostat to desired temperature, heater will cycle from low to high flame, if not:
  - a) If there is no power at the thermostat then the start switch is faulty
  - b) If there is no power at the high flame side of the 2 stage regulator then the thermostat is faulty
  - c) If there is power at the high flame side of the 2 stage regulator then the valve is faulty.

# S1505 HEATER PARTS

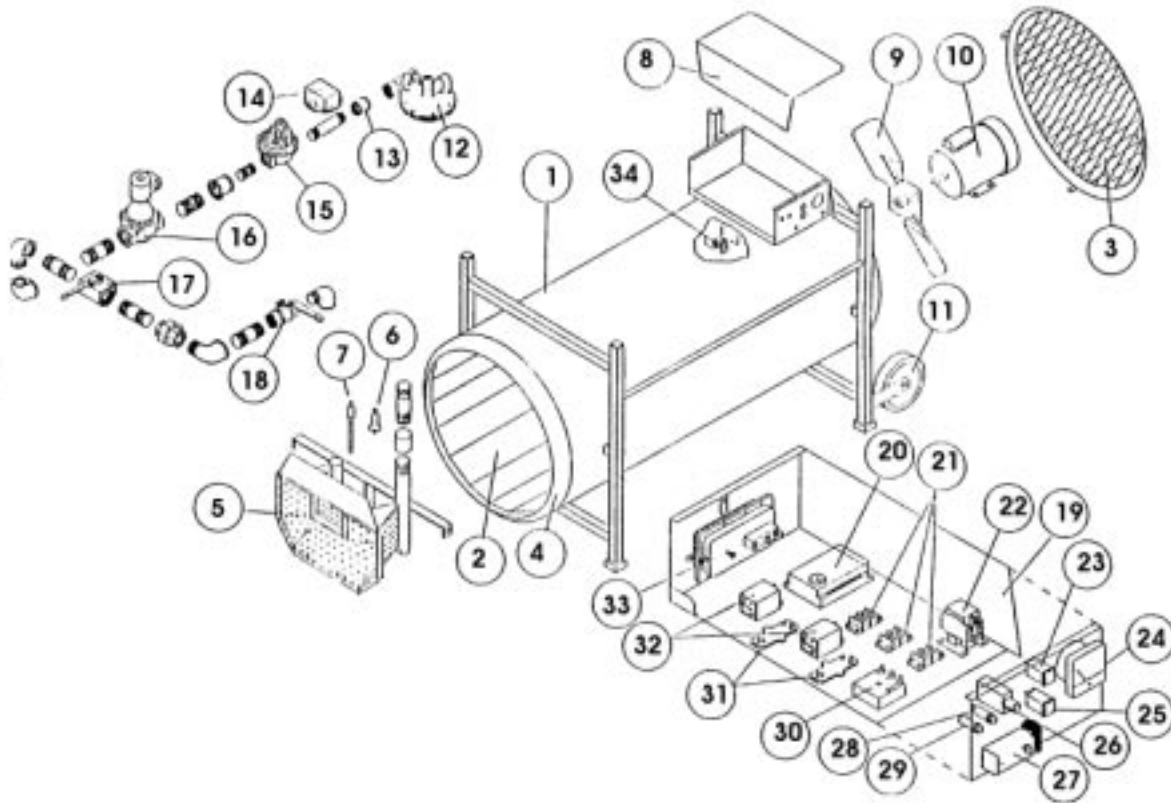

Item	Part No.	Description
1	SFP S1505-55	Heater Body Includes:2,4,5
	SFP S1505-56	Heater Body Includes:2, 4
2	SFP SL11B-90	Heat Shield
3	SFP SL11B-53	Screen
4	SFP SL11B-13	Nose Cone
5	SFP BV85-50	Burner
6	SFP 2143	Spark Plug
7	SFP SL11B-86	Flame Rod
8	SFP SL11B-35	Control Box Cover
9	SFP 2423	24" Fan Blade
10	SFP 2432	1 HP Electric Motor
11	SFP 6119	8" Semi Pneumatic Wheel
12	SFP 11SV08	Regulator (Optional) 10psi max
13	SFP S1500-83	1.25" Strainer
14	SFP 4509	Gas Pressure Switch
15	SFP 4490	1.25" 2 Stage Regulator Valve
16	SFP 2537	1.5" Solenoid Valve
17	SFP S1505-81	1.5" Gas Selector Valve
18	SFP 2539	1.5" Manual Shut-Off valve
19	SFP SL11B-58	Control Box
20	SFP 7462	Ignition Control Module

Item	Part No.	Description
21	SFP 5768	Terminal Block (3)
22	SFP 2436	Motor Starting Relay
23	SFP 3337G	ON Switch (Green)
24	SFP 5989	Voltmeter
25	SFP 3337R	OFF Switch (Red)
26	HWP HC1002	Circuit Breaker for item 20
27	SFP 2453	Thermostat
28	SFP 2506	Red Light
29	SFP 2505	White Light
30	SFP 5988	10-Second delay ON break timer
31	SFP 6440	Relay Clip
32	SFP 4512	Control Relay with clip
33	SFP 5355	Airswitch (0.5" W.C.)
34	SFP 2446	Hi Limit Thermoswitch

Parts Not Shown  
 DECDK1505 Decal Kit for S1505



# S1505 SCHEMATIC WIRING DIAGRAM

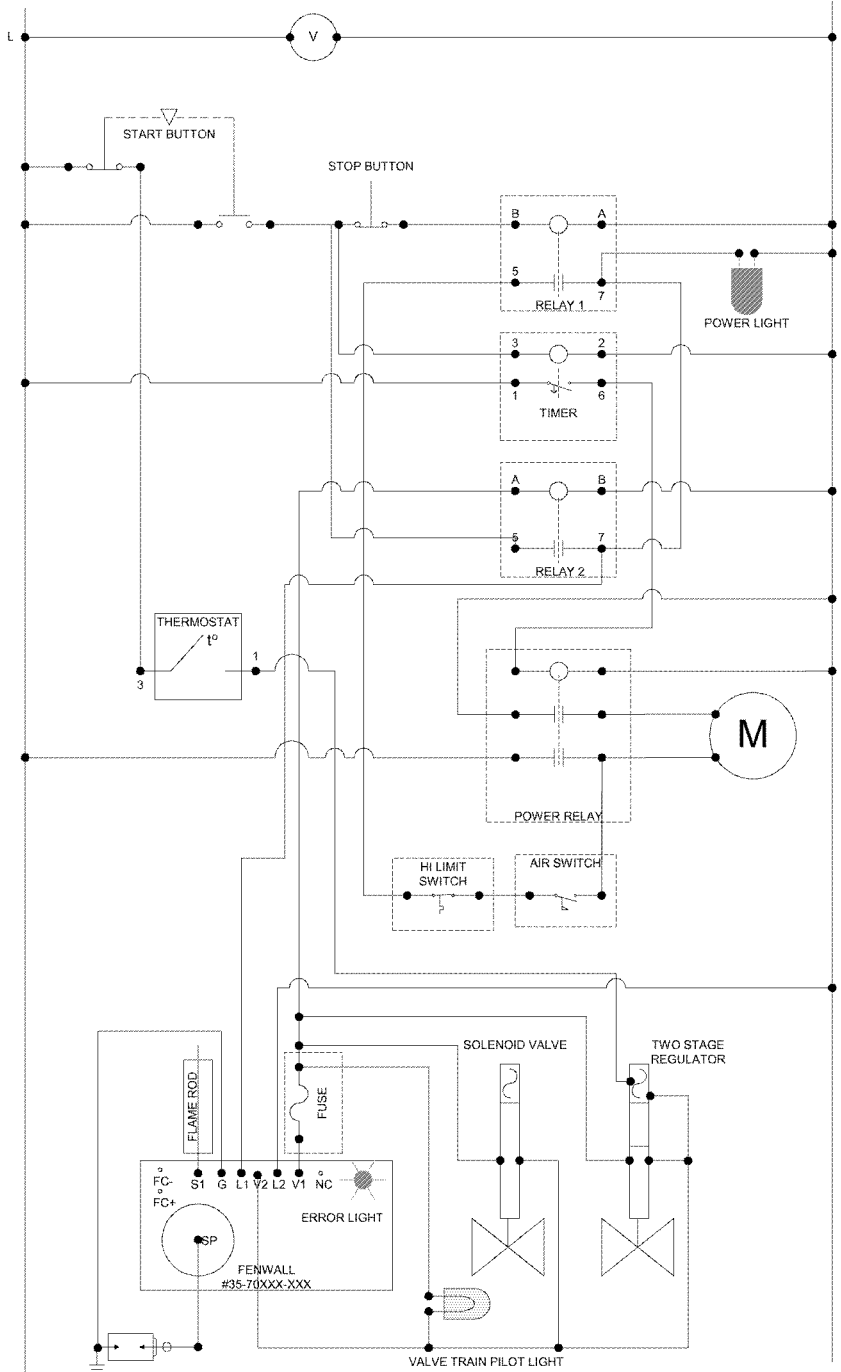

S1505 Manual 934-5730 -

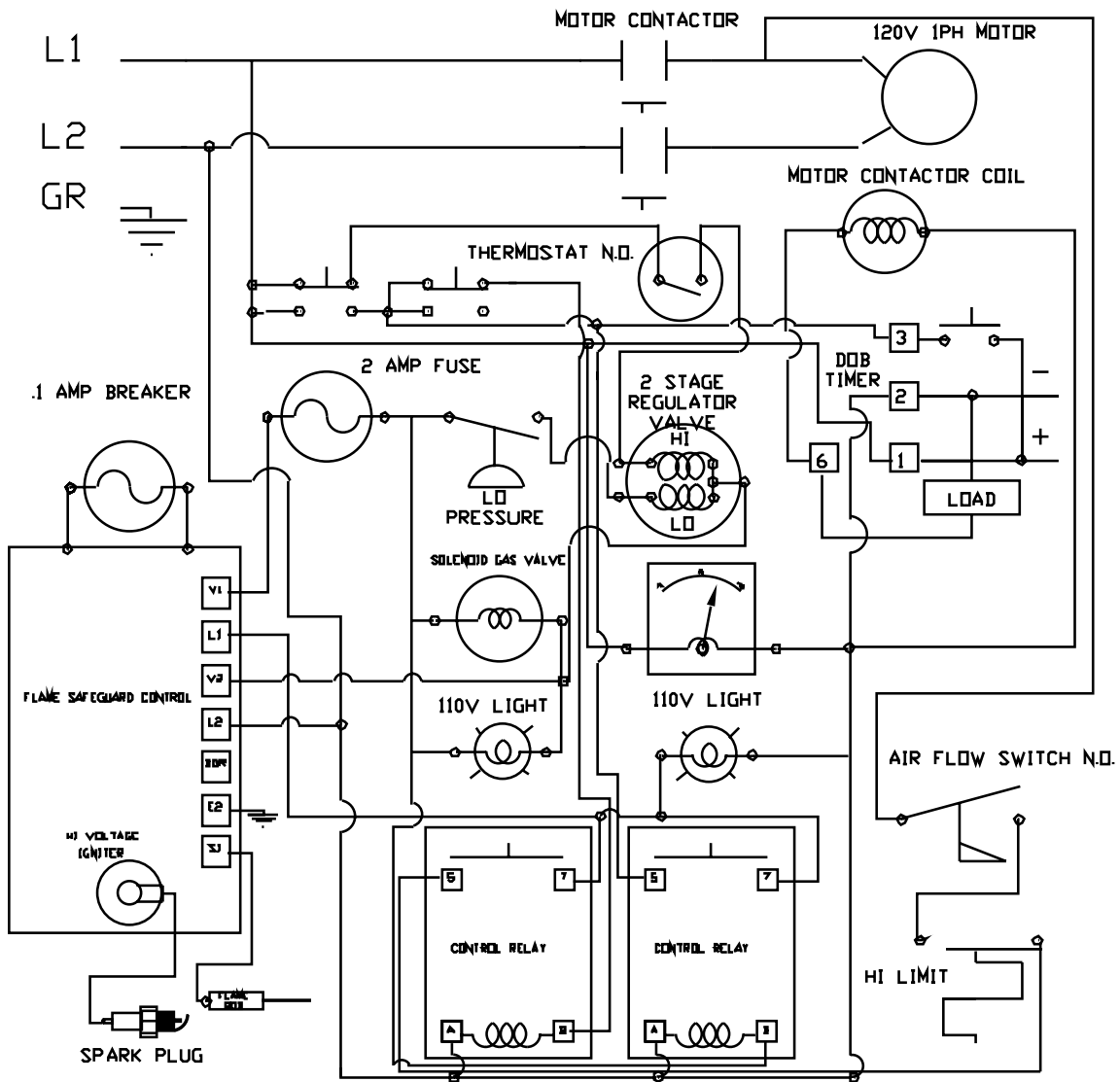

# Fuel Sizing Charts

VAPOR PROPANE QUICK  
REFERENCE HOSE  
CHART

Hose Length in Feet	BTU 1.5 Million	
	1/2PSI	10PSI
10	1-1/4	3/4
25	1-1/4	3/4
35	1-1/4	3/4
50	1-1/4	3/4
75	-	3/4
100	-	3/4
125	-	3/4
150	-	1-1/4
175	-	1-1/4
200	-	1-1/4
225	-	1-1/4

NATURAL GAS QUICK  
REFERENCE HOSE  
CHART

Hose Length in Feet	BTU 1.5 Million			
	<1PSI	1PSI	2PSI	5PSI
10	2	1-1/4	3/4	3/4
25	2	1-1/4	3/4	3/4
35	2	1-1/4	3/4	3/4
50	2	1-1/4	1-1/4	3/4
75	2-1/2	1-1/2	1-1/4	3/4
100	2-1/2	1-1/2	1-1/4	1-1/4
125	2-1/2	1-1/2	1-1/4	1-1/4
150	2-1/2	2	1-1/4	1-1/4

VAPORIZATION RATES IN BTUH @ 0 DEG. F							
TANK SIZE	NUMBER OF TANKS MANIFOLDED	PERCENTAGE OF TANK FILLED					
		10%	20%	30%	40%	50%	60%
500							
	1	198,135	264,180	308,212	352,240	396,270	440,300
	2	435,897	581,196	687,066	774,928	871,794	968,660
1000	3	758,857	1,011,809	1,180,451	1,349,079	1,517,714	1,686,349
	1	354,240	472,320	551,040	629,760	708,480	787,200
	2	779,328	1,039,104	1,212,288	1,385,472	1,558,656	1,731,840
	3	1,356,739	1,808,985	2,110,483	2,411,980	2,713,478	3,014,976

NOTE: USE FOLLOWING MULTIPLIERS FOR OTHER AIR TEMPERATURES

- For -10° F multiply x 0.50
- For + 10°F multiply x 1.5
- For +20°F multiply x 2.0
- For +40°F multiply x 3.0
- For +50°F multiply x 3.5
- For +60°F multiply x 4.0

Gas Regulated to 1/2 PSI Outlet, Providing 1.5 Mill BTUs

Stacking two regulators  
When you have less than  
10 PSI of Natural Gas

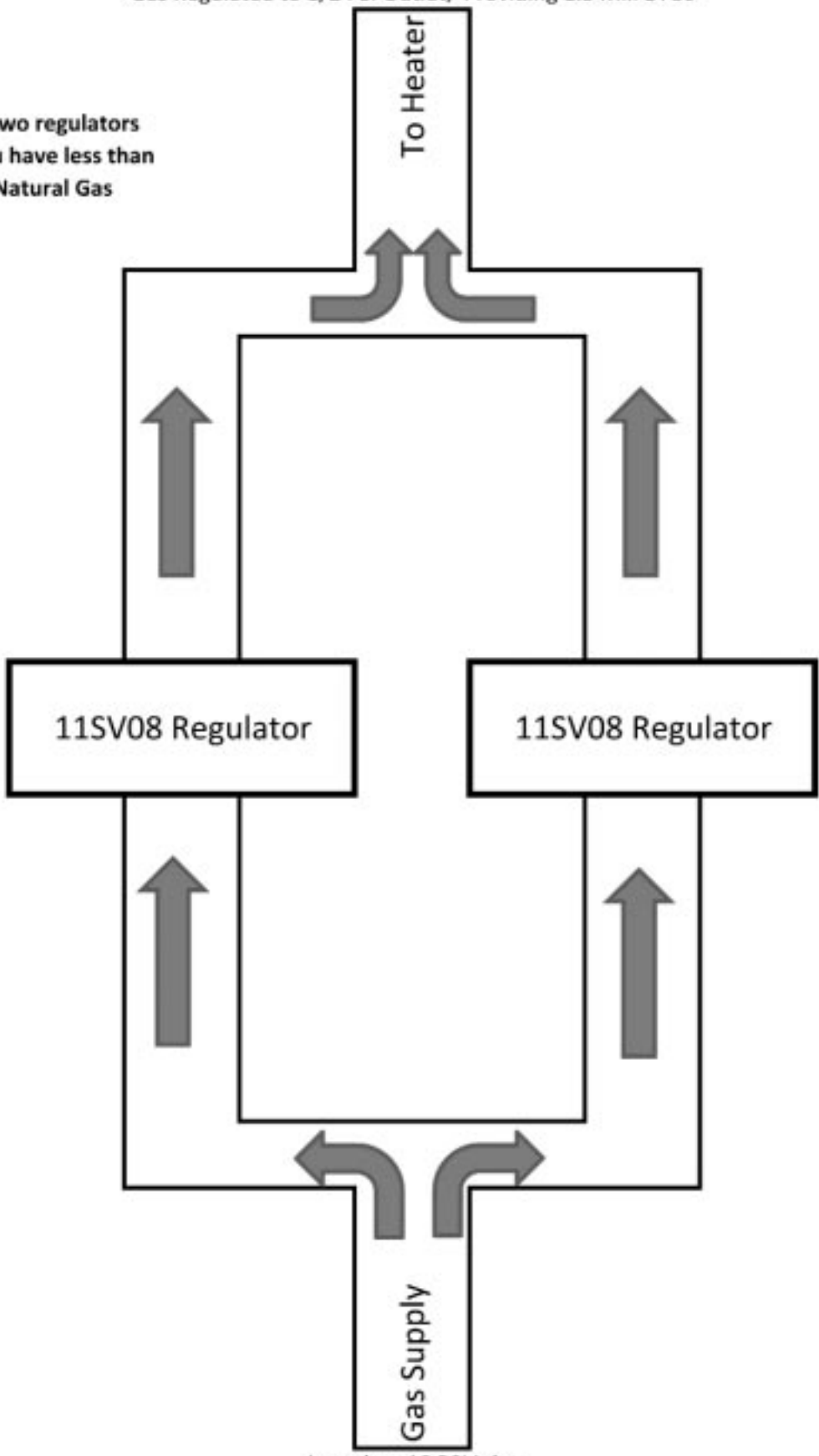

Less than 10 PSI Inlet