



342 N. Co. Rd. 400 East
Valparaiso, IN 46383
219-464-8818 • Fax 219-462-7985
www.heatwagon.com

Installation and Maintenance Manual

Please retain this manual for future reference.

950HS(L)

*Construction
Heater*

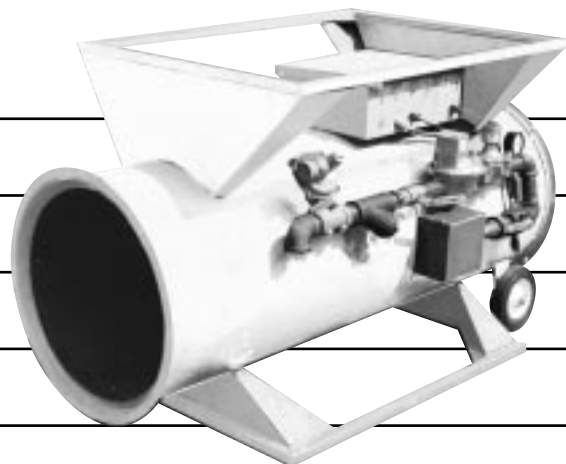

For your safety: Do not use this heater in a space where gasoline or other liquids having flammable vapors are stored.

MODEL 950HS & 950HSL

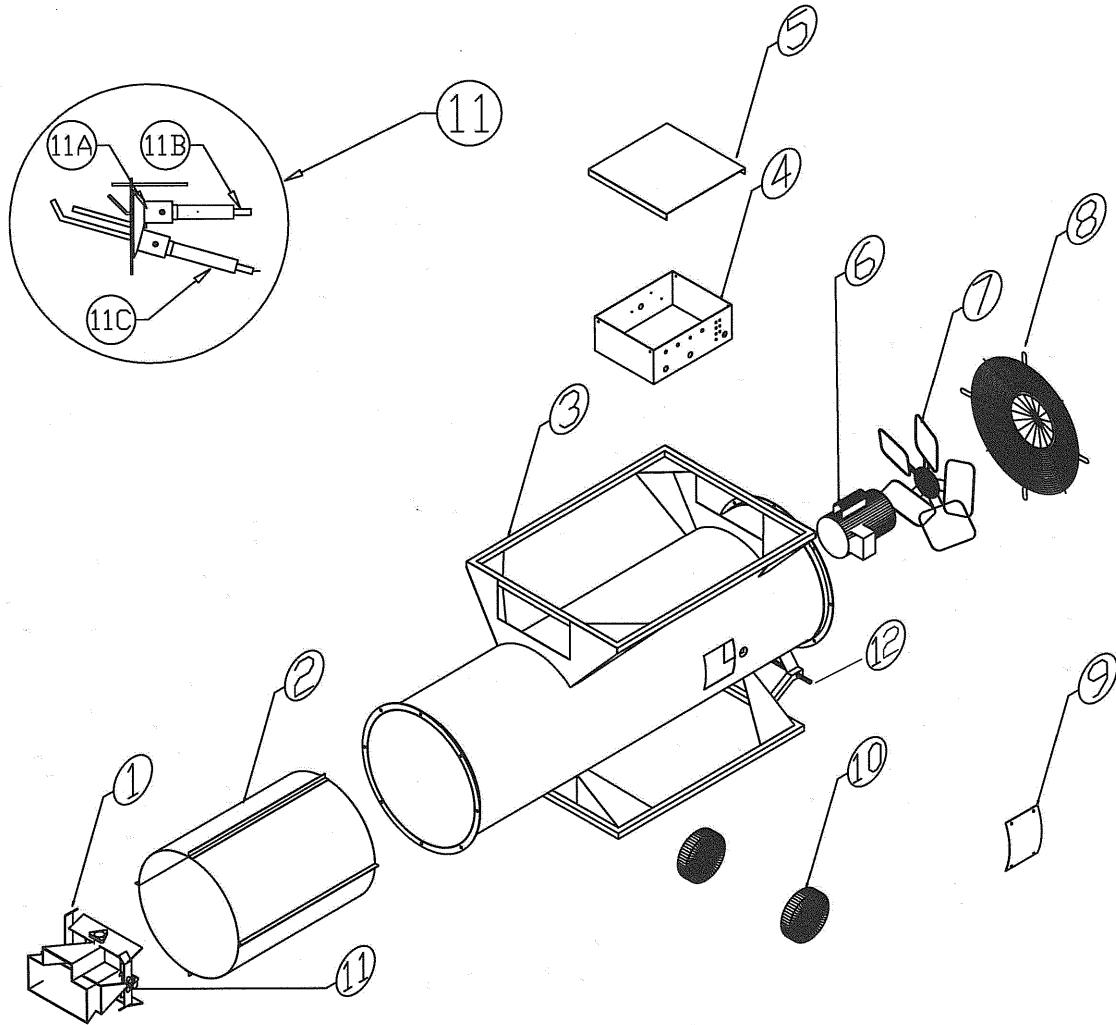

<u>Item</u>	<u>Part #</u>	<u>Description</u>
1	HWP HB1171B	Burner Complete
2	HWP HB1177C	Heat Shield
3	HWP HB950W	Heater Body Shell
4	HWP HC1083	Control Box
5	HWP HC1082	Control Box Lid
6	HWP HM1050	Motor
7	HWP HP1162	Fan Blade
8	HWP HG950H	Body
9	HWP HC1064	Burner Access Door
10	HWP HW1164	Wheel
11	HWP 1190310	Pilot w/Spark Rod and Flame Rod
11A	N/A	Pilot Assy. Bracket
11B	HWP 134290	Igniter
11C	HWP 136003	Flame Rod
12	HWP 40SC42	Axle

MODEL 950HS VAPOR PIPE TRAIN BREAKDOWN

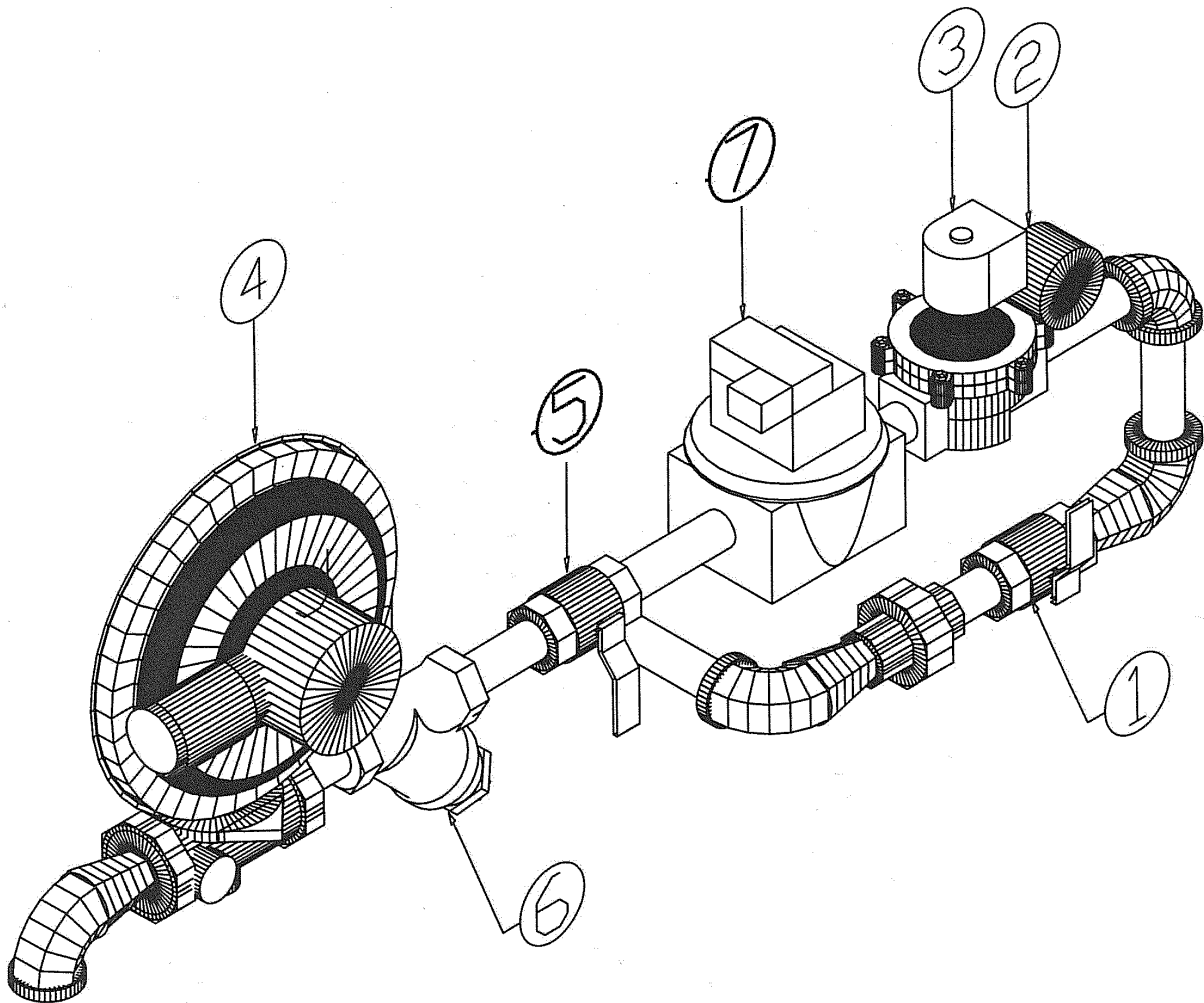

<u>Item</u>	<u>Part #</u>	<u>Description</u>
1	HWP HV1120	Gas Selector Valve 1-1/4" Locking
2	HWP HV1169	Gauge 15" W.C.
3	HWP HV1138	1-1/4" Solenoid Valve
4	ACC 11SV08	Regulator
5	HWP HV1121	1-1/4" Ball Valve
6	HWP HV1122	1-1/4" Y Strainer
7	SFP 4490	2 Stage Regulator Valve

CONTROL BOX PARTS

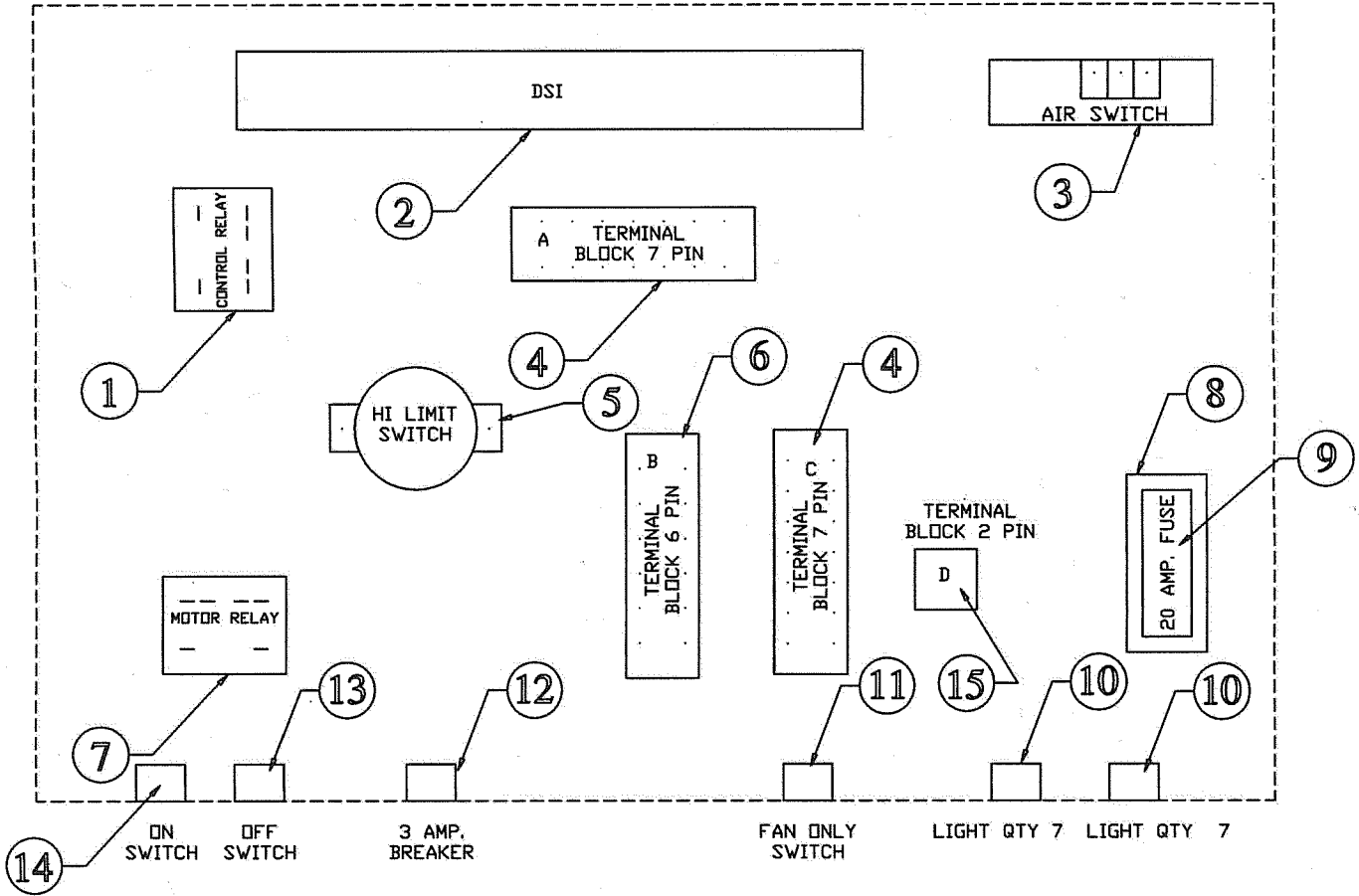

<u>Item</u>	<u>Part #</u>	<u>Description</u>
1	HWP 9264	Control Relay
2	HWP HC1001D	DSI Control
3	S1500-710	Air Switch
4	HWP HC1123	Terminal Block (A,C)
5	HWP 2446	Hi Limit Switch
6	HWP HC1123	Terminal Block (C)
7	HWP 9264	Motor Relay
8	HWP HC1122	Fuse Block
9	HWP HC1115	Fuse 20 amp
10	HWP 44130	Light
11	HWP HC1011	Fan Only Switch
12	HWP HC1019B	3amp Breaker
13	HWP HC1150	OFF Switch
14	HWP HC1149	ON Switch
15	HWP HC1123	Terminal Block (D)
16	HWP HC1120	Thermostat (w/o cord) (not shown)
17	HWP HC1020	Power cord (not shown)

CONTROL BOX WIRING

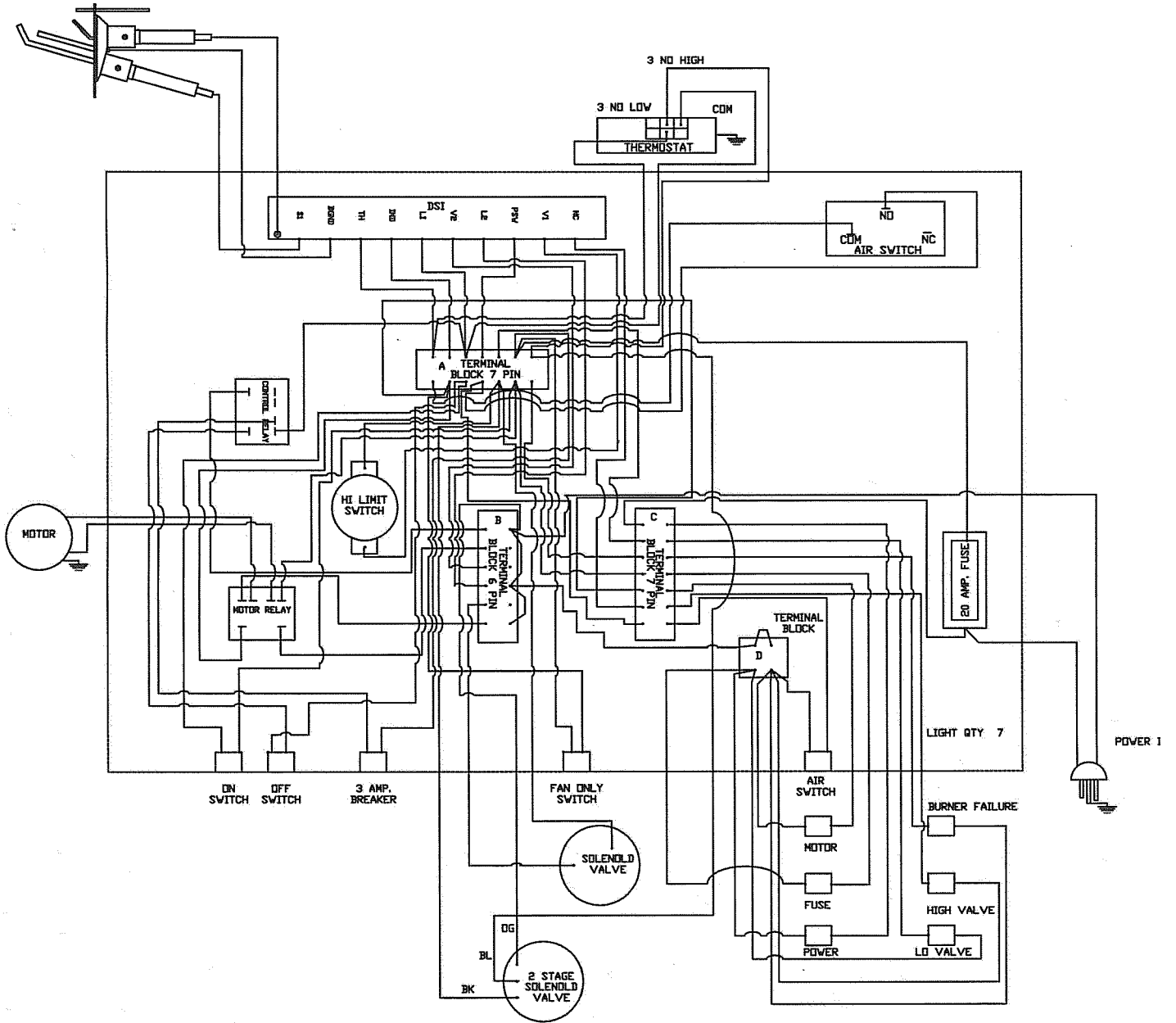

MAIN CIRCUIT DIAGRAM

