



342 N. Co. Rd. 400 East
Valparaiso, IN 46383
219-464-8818 • Fax 219-462-7985
www.heatwagon.com

Installation and Maintenance Manual

Please retain this manual for future reference.

VF1000

Construction Heater



For your safety: Do not use this heater in a space where gasoline or other liquids having flammable vapors are stored.

IMPORTANT INFORMATION! READ FIRST

The heater is designed for use as a construction heater under CSA-B140.8-1967 (General Requirements For Oil Burning Equipment) and UL-733 (Oil Fired Heaters and Direct Fired Heaters). Heater is not intended for use in pest remediation. The primary purpose of construction heaters is to provide temporary heating of buildings under construction, alteration, or repair and to provide emergency heat. Properly used, the heater provides safe, economical heating. Products of combustion are vented outside the area being heated.

Use of the heater must be in accordance with this Standard and in compliance with all governing state and local codes.

We cannot anticipate every use which may be made for our heaters. **CHECK WITH YOUR LOCAL FIRE SAFETY AUTHORITY IF YOU HAVE QUESTIONS ABOUT LOCAL REGULATIONS.**

Other standards govern the use of fuel gases and heat producing products in specific applications. Your local authority can advise you about these.

FOR YOUR SAFETY

DO NOT USE THIS HEATER IN A SPACE WHERE GASOLINE OR OTHER LIQUIDS HAVING FLAMMABLE VAPORS ARE STORED OR USED.

CONSTRUCTION HEATER GENERAL HAZARD WARNING:
Failure to comply with the precautions and instructions provided with this heater, can result in death, serious bodily injury and property loss or damage from hazards of fire, explosion, burn, asphyxiation, carbon monoxide poisoning, and/or electrical shock.

Only persons who can understand and follow the instructions should use or service this heater.

If you need assistance or heater information such as an instruction manual, labels, etc., contact your local Heat Wagon dealer or the manufacturer.

W A R N I N G

Fire, burn, inhalation, and explosion hazard. Keep solid combustibles, such as building materials, paper or cardboard, a safe distance away from the heater as recommended by the instructions. Never use the heater in spaces which do or may contain volatile or airborne combustibles, or products such as gasoline, solvents, paint thinner, dust particles or unknown chemicals.

Not for home or recreational vehicle use!

If you have read this entire manual and you still have questions, please call us at 219-464-8818

Installation and Maintenance Manual

Model VFI000

Construction Heater

Table of Contents:

	Page
Safety & Caution	4
Specifications	4
Operating Instructions	5
Troubleshooting	8
Maintenance	12
Illustrated Parts Breakdown	15
Wiring Diagrams	20
Exhaust Flue Pipe Guidelines	23

WARRANTY

All new Heat Wagon and Sure Flame heaters and fans are guaranteed against defective materials and workmanship for one (1) year from Heat Wagon invoice date.

Warranty repairs may be made only by an authorized, trained and certified Heat Wagon dealer. Warranty repairs by other entities will not be considered. Warranty claims must include model number and serial number. Components are guaranteed to the extent of the components manufacturer's warranty.

LIMITATIONS

Warranty claims for service parts (wear parts) such as spark plugs, igniters, and flame rods will not be allowed. Diagnostic parts such as voltage meters and pressure gauges are not warrantable. Evidence of improper fuel usage, fuel pressures outside of manufacturer's specification, poor fuel quality, and improper electric power, misapplication or evidence of abuse may be cause for rejection of warranty claims.

Labor, travel time, mileage and shipping charges will not be allowed. Minor adjustments of heaters are dealers' responsibility. Defective parts must be tagged and held for possible return to the factory for 60 days from date of repair. The factory will provide a return goods authorization, (RGA) for defective parts to be returned. No warranty will be allowed for parts not purchased from Heat Wagon.



342 N. Co. Rd. 400 East • Valparaiso, IN 46383
219-464-8818 • 888-432-8924 • Fax 800-255-7985
www.heatwagon.com

SAFETY & CAUTION

- Instructions given in this manual and the applicable regulation of the local authorities must be followed.
- The unit may be operated only by those persons who have been instructed in its proper use.
- The unit is to be installed and operated in such a way as to ensure safety of employees and surroundings.
- Never cover the unit's air openings.
- Always secure an adequate fresh air supply to the unit.
- Never stand in front of the discharge end of the heater.
- Unit's emitted noise level at the range of 3 feet: 74 dBA.
- Do not introduce foreign objects into the unit.
- Do not expose the unit to direct water jets.
- All electric cables outside the unit are to be protected against damage.
- Always disconnect the unit from power supply when maintenance or service is being performed.
- **IF NOT OPERATED WITHIN GUIDELINES OF THESE OPERATING INSTRUCTIONS MANUFACTURER WILL NOT BE HELD RESPONSIBLE AND WARRANTY WILL BECOME VOID.**

SPECIFICATIONS

Model No. VF1000

Fuels:	#1 or #2 Kerosene, Diesel, Heating Fuel		
Capacity:	1,000,000 BTU/HR		
Blower:	4,075 CFM	5.0HP	2.0"SP
Electrical Rating:	240 Volts, 1Ø 30 Amps		
Fuel Consumption:	7 GPH		
Remote Thermostat:	On/Off		
Max. Discharge Temp.:	200°F @ 0°F Ambient		
Duct Size:	20" Dia., 200 ft. max (straight)		
Shp. Dimensions	120"L x 31.5"W x 54"H		
Weight (approximate):	1,300 lbs.		

Fuel Supply:	Manifold Pressure (Fuel Pump)	Burner Nozzle
	125 psi	6GPH x 70°A

OPERATING INSTRUCTIONS

INSTALLATION

- When transporting, use all four lifting eyes in upper corners or forklift openings in the base of the units.
- Place the unit on a level and non-combustible surface.
- Minimum clearances from combustible materials for indoor or outdoor installation on combustible flooring:
 - outlet, minimum 10 feet
 - sides, minimum 3 feet
 - top, minimum 3 feet
 - flue pipe exhaust, gas discharge minimum 2 feet
- Manufacturer recommends a free zone of 5 feet around the unit and a minimum distance of 10 feet at the unit's flue gas openings are to be maintained.
- If the unit is placed indoors, secure an adequate fresh air opening for the burner combustion air
- The unit may not be installed and operated in premises where explosive or combustible fumes or dust are present. Check the regulation of local authorities, when necessary.
- Make sure that neither the air inlet nor the air outlet is obstructed.

FUEL SUPPLY

- This heater will burn kerosene (#1 or #2), diesel fuel (#1 or #2) and heating fuel (#1 or #2). It is highly recommended to use winterized fuel with ambient temperatures less than 20°F and install optional circulation or fuel tank heaters.
- Visually inspect the hose assembly and ensure that it is protected from traffic, building materials, and contact with hot surfaces. If it is evident that there is excessive abrasion or wear, or the hose is cut, it must be replaced.
- After installation, check the hose assembly for leaks.
- Fuel hose must be UL approved.
- The installation of this heater must comply with all applicable local codes.
- Check and clean fuel filter (if necessary) on a weekly schedule.

ELECTRICAL

- Electric cable extensions must be connected based on the unit capacity and cable length.
- Connect unit to a power supply with a suitable appliance receptacle (30 Amp). Green indicator lamp will light up.
- Confirm voltage at heater connection (208V min.) to ensure proper operation.

EXHAUST FLUE PIPE

- The unit is to be connected to a flue pipe with adequate draft, to ensure the proper start and operation of the unit. Refer to page 23.
- The flue pipe is to be made of non-combustible material and clearances from combustible materials must be a minimum 8 inches (temperature of flue gases is approximately 410° F).
- The flue pipe and its installation must comply with the regulations and instructions given by the local authorities.

START UP

- Only people who are trained in the operation and supervision of this heater should operate and maintain the unit.
- Check the unit to make sure that there are no visible defects on the control and safety devices and that the unit has been installed correctly.
 1. Open door at back of unit (control box compartment).
 2. Check that the control switch in the control box is in position "0" (STOP).
 3. Pre-select desired room temperature on the room thermostat. The temperature must be set higher than the ambient temperature.
 4. Turn the control switch in control box to position "1" (HEATING).
 5. Let the burner circulate fuel through the fuel circulation heater until the fuel circulation heater light goes out (2 to 5 minutes) then turn on the burner toggle switch.
 6. When the ambient temperature level is low, the burner switches on automatically. The fan does not switch on until the set temperature (104°F) of the heat-exchanger has been reached (will take approximately 1-5 minutes).
 7. The green indicator lamps for "heating on" and "fan on" will light up now.
 8. Close the door in order to protect the unit against unauthorized adjustments.
- After starting, the unit runs fully automatically with the pre-selected room temperature thermostat and it is controlled by its own control devices and safety limit controls.
- The room thermostat (TSTAT) and burner sensor control the running sequences of the burner and the fan sensor controls the fan function.
- Overheat limit reset (STB) controls and shuts off the heater (burner) in the case of an emergency.
- The unit can also be used for ventilation purposes only, if needed.
 1. Turn the control switch in control box to position "2" (VENTILATION).
 2. The unit is now in the continuous ventilating mode.
 3. Heating is not possible in this mode.

DUCTING (Warm Air)

- Clearance from combustible materials have to be a minimum of 4 inches.
- Use steel ducting or fabric ducting capable of withstanding maximum temperature of 300°F.
- Maximum length of duct: 200' (straight).
- Duct diameter: 20".
- Make sure that the duct is safely and properly fastened to the warm air outlet.
- Avoid sharp bends and corners to ensure maximum air flow and avoid back pressure/heat accumulation in heater.
- FAILURE TO COMPLY WITH THESE RECOMMENDATIONS COULD RESULT IN SHUTDOWN OF THE HEATER.

SHUT DOWN

- Turn control switch to position "0" (STOP).

Important!

The air supply fan continues running to cool down the combustion chamber/heat exchanger and then stops later. The fan can restart several times before finally switching off!

WARNING!

ELECTRICAL POWER TO THE UNIT MAY BE DISCONNECTED IN EMERGENCY SITUATIONS ONLY. OTHERWISE, DO NOT STOP THE UNIT BY DISCONNECTING POWER. UNIT NEEDS TO COOL DOWN USING ITS OWN FAN. FAILURE TO COMPLY WITH PROPER SHUT-DOWN PROCEDURES CAN CAUSE DAMAGE TO THE COMBUSTION CHAMBER, HEAT EXCHANGER, SAFETY FEATURES AND VOID WARRANTY.



VF1000 TROUBLESHOOTING

Symptom

1. I turn the heater to position #1 and nothing happens.

Possible Causes

- Power supply cord
- Burner reset button on the burner flame safeguard control box is popped
- Overheat limit switch is tripped
- Burner motor relay is faulty
- Burner sensor is faulty
- Heater control unit (HCU) is faulty

Possible Solutions

- Test for 240 volts between L1 and L2 on the main terminal block.
- Reset the button on the flame safeguard control.
- Reset the switch, which is located in the burner compartment on the gray box on the left hand side of the burner.
- Burner motor relay is located in the main control box (K2). Check between ground and L1, then ground and T1 for 120 volts. Replace if necessary.
- On the heater control unit (HCU) disconnect the wires from terminals X10 and X11. Using an ohm meter, check the resistance between the two wires using the 1K ohms chart on page 18.
- On the main terminal block, check for 120 volts between terminals 8 and N when the 3-position switch is in the HEAT position.

2. The heater runs for a little while, but shuts down. It won't come on again until I reset the limit switch.

- Burner nozzle is improperly sized
- Incorrect burner fuel pump pressure
- Restricted airflow

- Nozzle is 6 GPH x 70° A.

- Use a high pressure gauge (160 PSI) with a 1/8" NPT inlet. Install gauge in the pressure tap port located on the top of the fuel pump. Run the unit and adjust the manifold pressure by turning the pressure adjusting screw (on the right hand side of the fuel pump) in or out until the gauge reads 125 PSI.
- Check for dirt or ice buildup on the air inlet or blower wheel. If using duct on the air outlet, insure the back pressure does not exceed a static pressure of 2" W.C. Check with magnehelic gauge if necessary.
- Adhere to the proper shut down procedures. Power must remain at the unit until it cools down fully. Blower will shut down on its own when cool. Test overheat limit switch for continuity between the two male terminals at room temperature. Replace if overheat limit switch fails test.

VF1000 TROUBLESHOOTING

Symptom

3. I get the burner motor to come on, but the heater won't ignite.

Possible Causes

- Fuel pressure or volume
- Air inlet damper adjustment
- Ignition electrodes
- Electronic igniter
- Solenoid valve

Possible Solutions

- Use a high pressure gauge (160 PSI) with 1/8" NPT inlet. Install gauge in the pressure tap port located on top of the fuel pump. Run the heater. Adjust the pressure by turning the pressure adjusting screw (located on the right hand side of the fuel pump) counter clockwise until the gauge reads 125 PSI.
- Rough setting at 1-1/4" open. Minor adjustments from the rough settings can be made to achieve a smooth sounding burner with no soot from the flue pipe.
- Clean with fine sandpaper. Make sure it is free from buildup or cracks.
- Turn off the gas valve, turn on the burner. Use insulated pliers to hold the igniter. Pull the igniter away from electrodes slowly. A rainbow colored arc should travel between the igniter and the electrodes at a distance of 3/8 of an inch for a duration of 4-5 seconds.
- If there is power at the flame safeguard control and no power out to the solenoid valves, replace the flame safeguard control. Check for continuity between the terminals on the solenoid valve coil.

4. The heater has a loud rumbling sound.

- Air damper setting
- Dirt on burner blower wheel
- Flue pipe setup or flue pipe restrictions
- Fuel pump pressure
- Fuel nozzle size
- Restricted heat exchanger

- Rough setting at 1-1/4" open. Minor adjustments from the rough settings can be made to achieve a smooth sounding burner with no soot from the flue pipe.
- Clean the burner blower wheel with a small brush.
- Refer to the flue pipe chart in this manual. Check flue for restriction.
- Use a high pressure gauge (0-160 PSI) with 1/8" NPT inlet. Install gauge in the pressure tap port located on top of the fuel pump. Run the heater. Adjust the pressure by turning the pressure adjusting screw (located on the right hand side of the fuel pump) counter clockwise until the gauge reads 125 PSI. pressure.
- Nozzle is 6 GPH x 70° A.
- Refer to the cleaning instructions in this manual.

VF1000 TROUBLESHOOTING**Symptom****Possible Causes****Possible Solutions**

- | | | |
|--|--|---|
| <p>5. The heater blows black smoke out of the vent stack.</p> | <ul style="list-style-type: none"> • Air damper setting • Dirt on burner blower wheel • Flue pipe setup or flue pipe restrictions • Fuel pump pressure | <ul style="list-style-type: none"> • Rough setting at 1-1/4" open. Minor adjustments from the rough settings can be made to achieve a smooth sounding burner with no soot from the flue pipe. • Clean the burner blower wheel with a small brush. • Refer to the flue pipe chart in this manual. Check flue for restriction. • Use a high pressure gauge (0-160 PSI) with 1/8" NPT inlet. Install gauge in the pressure tap port located on top of the fuel pump. Run the heater. Adjust the pressure by turning the pressure adjusting screw (located on the right hand side of the fuel pump) counter clockwise until the gauge reads 125 PSI pressure. • Clean or replace fuel filter. • Nozzle is 6 GPH x 70° A. • Refer to the cleaning instructions in this manual. |
| <p>6. The burner seems to cycle on and off more than what it should.</p> | <ul style="list-style-type: none"> • Restricted fuel filter • Fuel nozzle size • Restricted heat exchanger | <ul style="list-style-type: none"> • Use a high pressure gauge (0-160 PSI) with 1/8" NPT inlet. Install gauge in the pressure tap port located on top of the fuel pump. Run the heater. Adjust the pressure by turning the pressure adjusting screw (located on the right hand side of the fuel pump) counter clockwise until the gauge reads 125 PSI pressure. • Clean or replace fuel filter. • Check for dirt or ice buildup on the air inlet or blower wheel. If using duct on the air outlet, insure the back pressure does not exceed a static pressure of 2" W.C. • On the heater control unit (HCU) disconnect the wires from terminals X10 and X11. Using an ohm meter, check the resistance between the two wires using the 1K ohms chart on page 18. • If all of the above check good, replace the HCU. |

VF1000 TROUBLESHOOTING

Symptom

Possible Causes

- | | | |
|---|---|---|
| <p>7. The burner starts, but the main fan never comes on.</p> | <ul style="list-style-type: none"> • Fan sensor • Heater Control Unit (HCU) • Blower motor relay • Current overload on blower motor • Blower motor | <h3><u>Possible Solutions</u></h3> <ul style="list-style-type: none"> • On the heater control unit (HCU) disconnect the wires from terminals X12 and X13. Using an ohm meter, check the resistance between the two wires using the 1K ohms chart on page 18. • Turn the 3-position main switch to the fan position. If the blower runs, check the fan sensor. If it is good, replace the HCU. • Turn the 3-position main switch to the fan position. If the relay pulls in, check for voltage between the L1 and L2 terminals. Then check the voltage between terminals T1 and T2. The voltage should be the same. If it is much lower, replace the relay. • Push the reset button on the overload between terminals A1 and A2 on the motor relay. If there is no voltage, replace the overload. • Turn the 3-position main switch to the fan position. Check for voltage between terminals T1 and T2 on the motor relay. If the voltage is good, replace the motor. |
| <p>8. The burner continues to run, but the fan cycles on and off.</p> | <ul style="list-style-type: none"> • Fuel pump pressure • Fan sensor • Heater Control Unit (HCU) | <ul style="list-style-type: none"> • Use a high pressure gauge (0-160 PSI) with 1/8" NPT inlet. Install gauge in the pressure tap port located on top of the fuel pump. Run the heater. Adjust the pressure by turning the pressure adjusting screw (located on the right hand side of the fuel pump) until the gauge reads 125 PSI pressure. • On the heater control unit (HCU) disconnect the wires from terminals X12 and X13. Using an ohm meter, check the resistance between the two wires using the 1K ohms chart on page 18. • Turn the 3-position main switch to the fan position. If the blower runs, check the fan sensor. If it is good, replace the HCU. |

MAINTENANCE

Prior to starting any maintenance work, wait until unit cools down fully and fan shuts off before unplugging unit and beginning any maintenance work.

(Shut Down Procedures page 7)

To ensure the proper function of the unit, it must be serviced on regular basis. Maintenance can be performed, (excluding the control devices and safety limit controls), by an authorized trained & certified Heat Wagon dealer. The control devices and safety limit controls do not need routine maintenance. If these items fail they must be replaced.

- Do not use any aggressive cleaning agents, (which are harmful or environmentally unfriendly), when cleaning the unit.
- Do not use water jet when cleaning the unit.
- Pressurized air may be used for maintenance. Be careful not to damage the fan blower wheel with too much pressure.
- Check whether the unit is free from mechanical damage, replace faulty parts as necessary.
- Check fan blower wheel at regular intervals and clean it when needed.
- Check functionality of control and safety devices regularly.
- Have the flue gas values of the burner checked regularly by authorized agents.
- Be sure to store the unit in a dust free and dry place when it is not used for a long period of time. Cover the exhaust flue to prevent entry of foreign objects.

SERVICE

- The complete unit, including heat exchanger, combustion chamber and burner should be cleaned from dust and dirt after every heating period, at a minimum of once per year.

-Removal of combustion chamber/heat exchanger:

For proper cleaning of the unit, manufacturer recommends removal of the complete combustion chamber with heat exchanger. Clean combustion chamber and exchanger tube with brush. Vacuum all loose ash and soot. Close all cleaning flanges carefully to avoid damage to gasket material.

-Disassembling of burner:

1. Disassemble four tightening bolts on the combustion chamber flange and remove burner's mounting flange. Take care not to damage the flange seal.
2. Pull out the burner. Take care not to damage the burner head and power cable. Clean blower wheel, ignitor electrodes, and photocell. Replace fuel nozzle and fuel filter.

Refer to separate burner manual for adjustment of burner.

Disassembling of burner:

1. Pull out the burner. Take care not to damage the burner head and power cable.
2. Disassemble four tightening bolts on the combustion chamber flange and remove burner's mounting flange. Take care not to damage the flange seal.

Next step:

1. Pull off collar (1) from flue gas adapter after having removed the fixing screws.
 2. Disassemble flue gas adapter (2) from combustion chamber and pull it off.
 3. Disassemble center side panel (3) and insulation (4).
- Manufacturer recommends removing the left center side panel (seen from the control box end).
4. Disassemble tightening bolts at supports of combustion chamber (5) and pull out combustion chamber sideways.

Important! Take care not to bend or damage supports of combustion chamber!

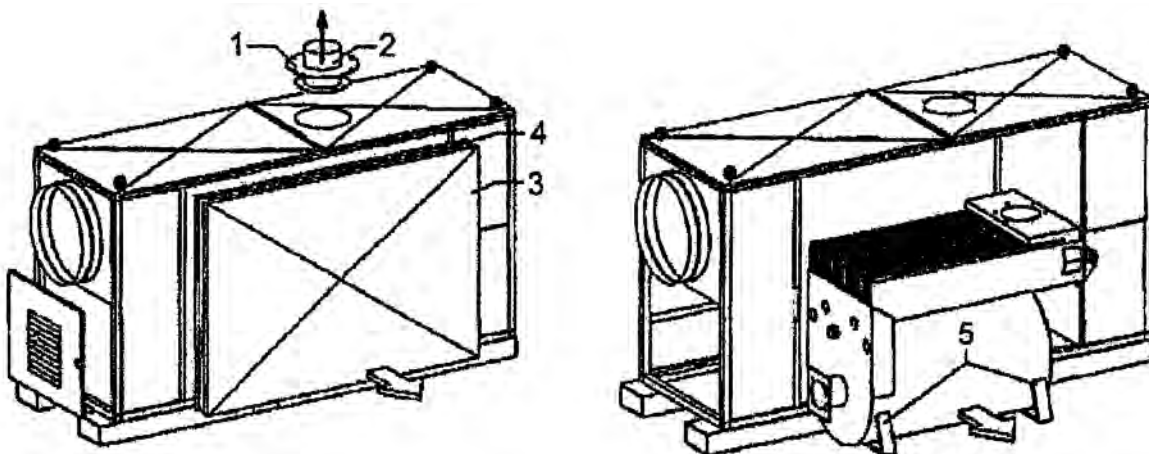

Heat exchanger

When cleaning the heat exchanger:

1. Disassemble revision cover of a heat exchanger (1).
2. Beware of gasket.
3. Pull all flue gas suppressors (5) (all 15 pcs) out from flue gas passages. Do not bend them.
4. Clean all flue gas passages (6) with a brush or vacuum cleaner.
5. Clean flue gas suppressors or replace them, if necessary.
6. Check gasket of revision cover and replace, if necessary.

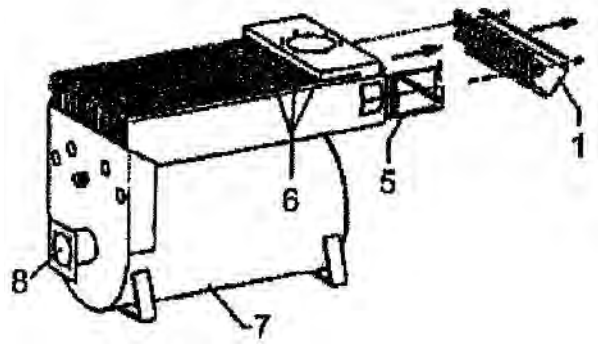

-Re-assembly of the unit.

Heat exchanger:

1. Replace all removed parts in reverse order.
2. Make sure that the gaskets and the revision cover (1) are correctly seated.

Combustion chamber and burner:

1. Assemble combustion chamber carefully into unit and adjust it. Tightening bolts of supports should be left loose (final tightening after installing the burner's mounting flange).
2. Install burner's mounting flange.
3. Check flange gasket and replace, if necessary.
4. Tighten the tightening screws of combustion chamber supports.
5. Remount all trim panels.
6. Remount flue gas adapter properly and also check gaskets and replace, if necessary.
7. Install burner to the mounting flange. Take care not to damage the burner head and power cable.
8. Re-install all connections and joints and check them thoroughly.
9. Put unit into service and check proper function of all operating modes.
10. Adjust the burner, if necessary.

Important!

An operation or use other than that indicated in these instructions is prohibited!

If unit is used in any way other than intended and explained in this manual, manufacturer will not be held responsible and the warranty will become void.

**VF1000
PARTS
BREAKDOWN**

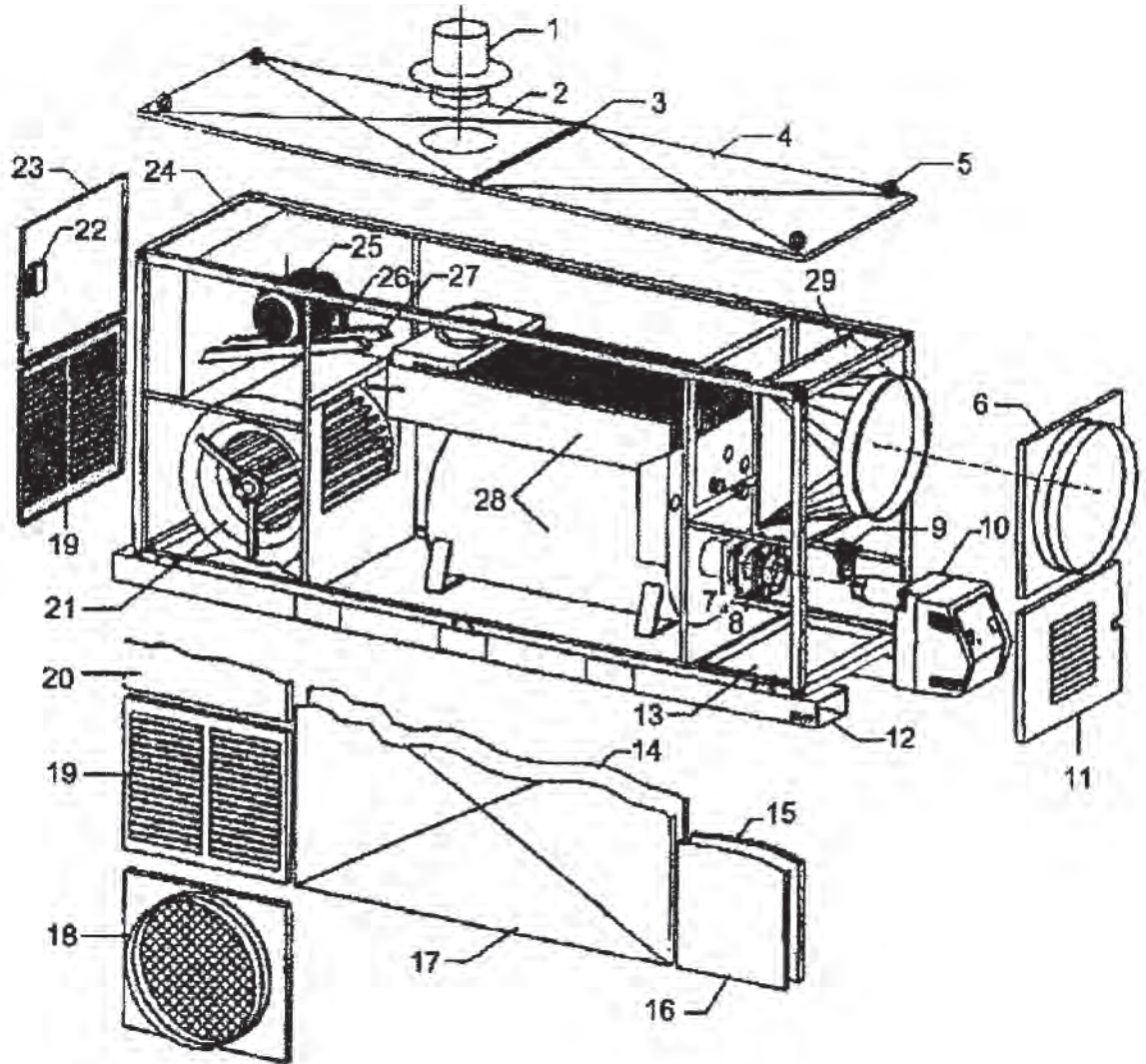

ITEM	PART#	DESCRIPTION	ITEM	PART#	DESCRIPTION
1	HWP 214401	Flue Gas Adapter	20	HWP 214420	Upper Side Panel, Fan End (2)
2	HWP 214402	Cover Plate, Rear	21	HWP 214421	Radial Fan
3	HWP 214403	Connecting Profile	22	HWP 214422	Door Belt
4	HWP 214404	Cover Plate, Front	23	HWP 214423	Control Compartment Door
5	HWP 214405	Crane Eye (4)	24	HWP 214424	Main Control Box
6	HWP 214406	Air Outlet Adapter	25	HWP SM6162	Fan Motor
7	HWP 20529	Flange Seal	26	HWP A68	V-Belt (2 Required)
8	HWP 20471	Oil Burner Flange	27	HWP 214427	Guide Rail (2 Required)
9	HWP 110121	Fuel Filter	28	HWP 214428	Combustion Chamber & Heat Exchanger
10	HWP 110008	Oil Burner	29	HWP 214429	Air Outlet Cone
11	HWP 214411	Burner Compartment Door	Not Shown		
12	HWP 214412	Base	HWP 214430	HWP 214430	Top Radiation Shield
13	HWP 214413	Oil Collector	HWP 214432	HWP 214432	Revision Cover
14	HWP 214414	Insulation, Center (left/right)	HWP 214433	HWP 214433	Gasket for Revision Cover
15	HWP 214415	Insulation, Burner End (left/right)	HWP 214434	HWP 214434	Flue Gas Suppressors
16	HWP 214416	Side Panel, Burner End (2, with louvres)	HWP 214435	HWP 214435	Drive Pulley, Fan
17	HWP 214417	Side Panel, Center (left/right)	HWP 214500	HWP 214500	Centrifugal Clutch/Motor Sheave
18	HWP 214418	Air Inlet Adapter (1, left/right/right options)	HWP 214501	HWP 214501	11-3/8" Fan Sheave
19	HWP 214419	Louvre Panel, Fan End (2, left/right/right options)	HWP 214502	HWP 214502	Sheave Bushing Fan
			HWP 3070	HWP 3070	Heat Wagon Logo Decal
			HWP 120004	HWP 120004	Oil Wand
			HWP 120020	HWP 120020	Oil Hose (13 feet)
			HWP 120211	HWP 120211	Oil Hose (3 feet)
			HWP 20529	HWP 20529	Burner Gasket
			HWP HV1060	HWP HV1060	0-300 PSI Liquid Filled Gauge
			HWP 65900	HWP 65900	Restraint for TH Sensors



WAYNE BURNER PARTS BREAKDOWN

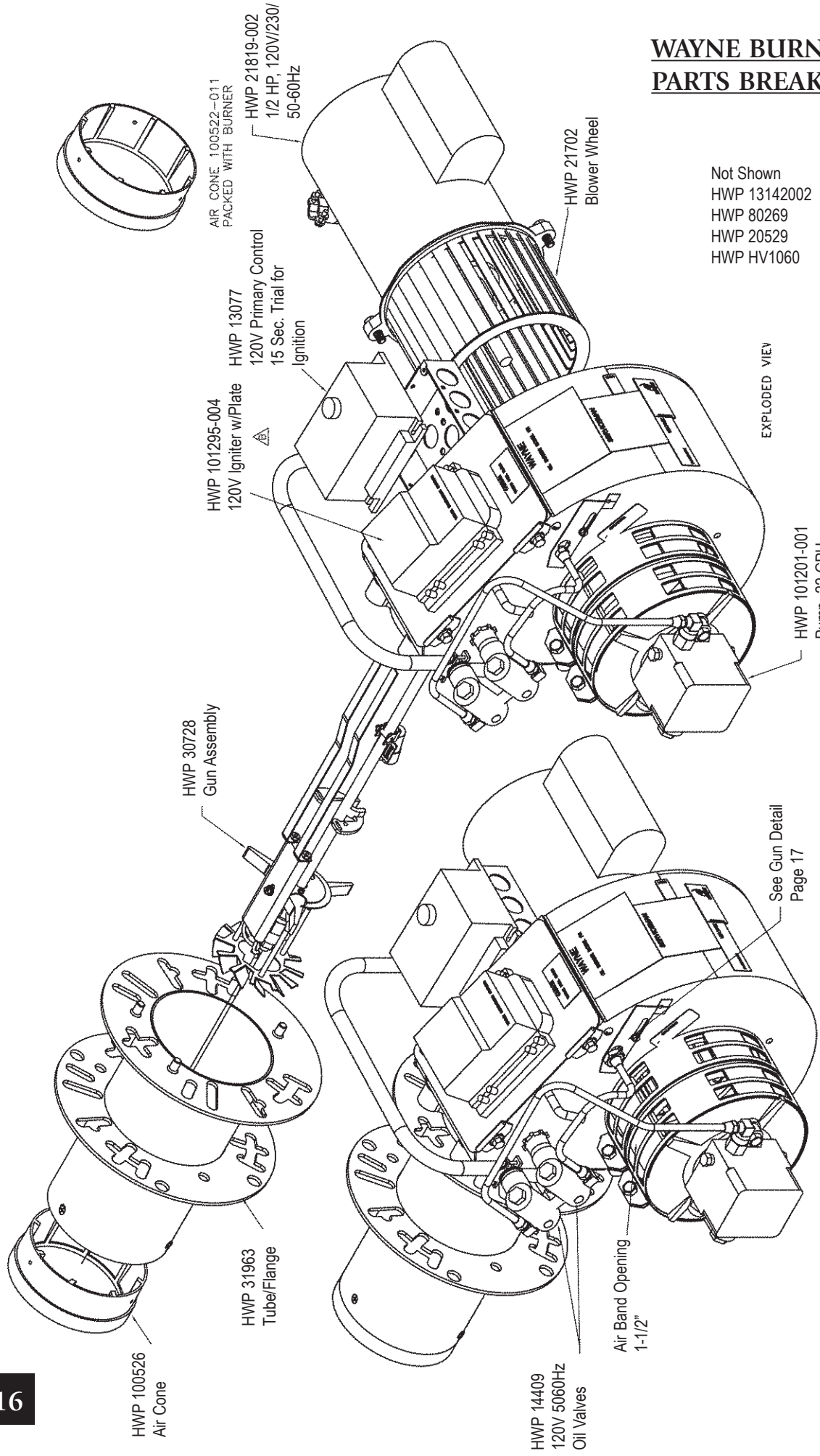

- Not Shown
- HWP 13142002 Pump Coupler
- HWP 80269 White Plastic Pump Coupler
- HWP 20529 Burner Gasket
- HWP HV1060 0-300 PSI Liquid Filled Gauge

EXPLODED VIEW



WAYNE BURNER PARTS BREAKDOWN

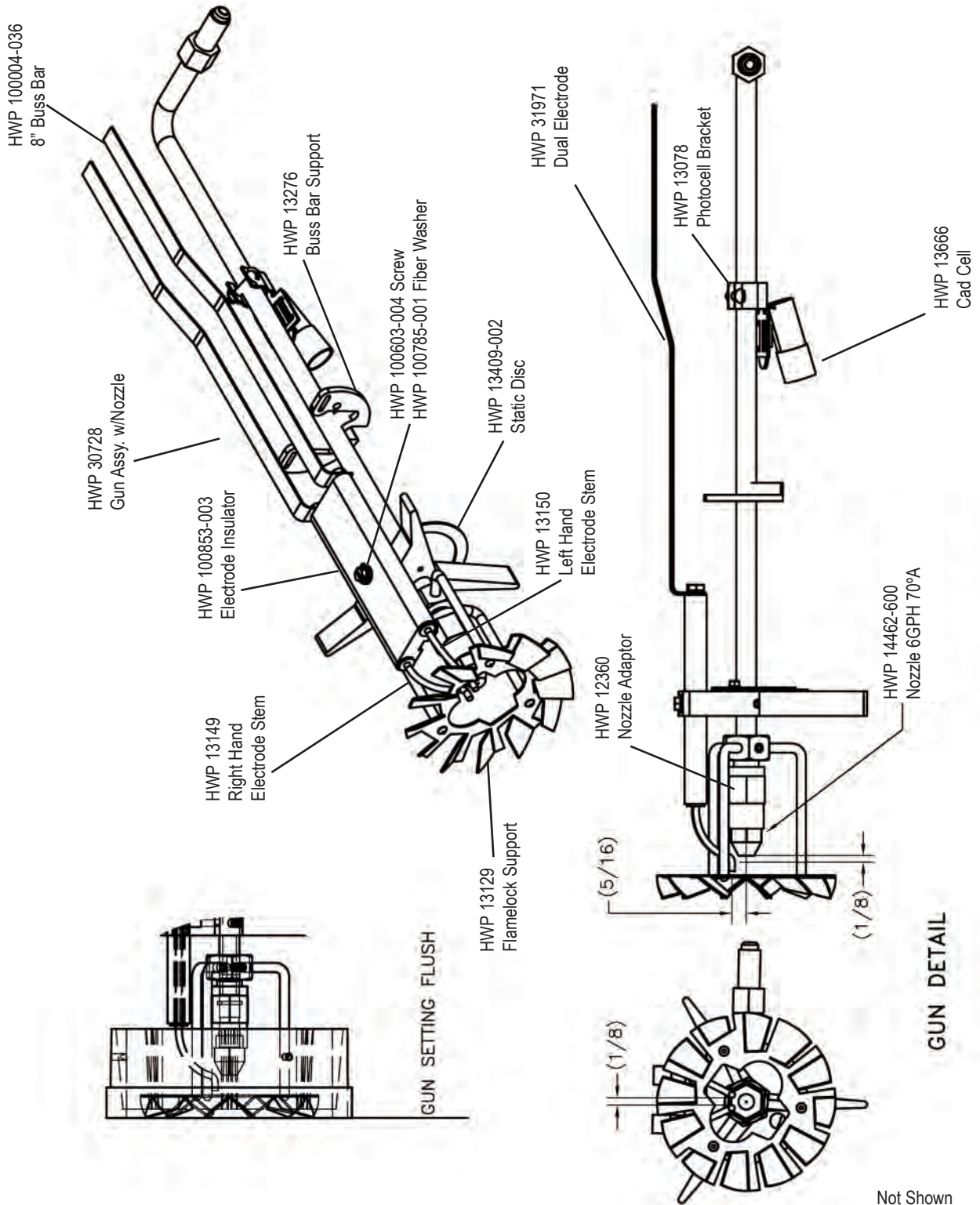

Not Shown
 HWP 12361
 Nozzle Adaptor Disc

FUEL FLOW DIAGRAM

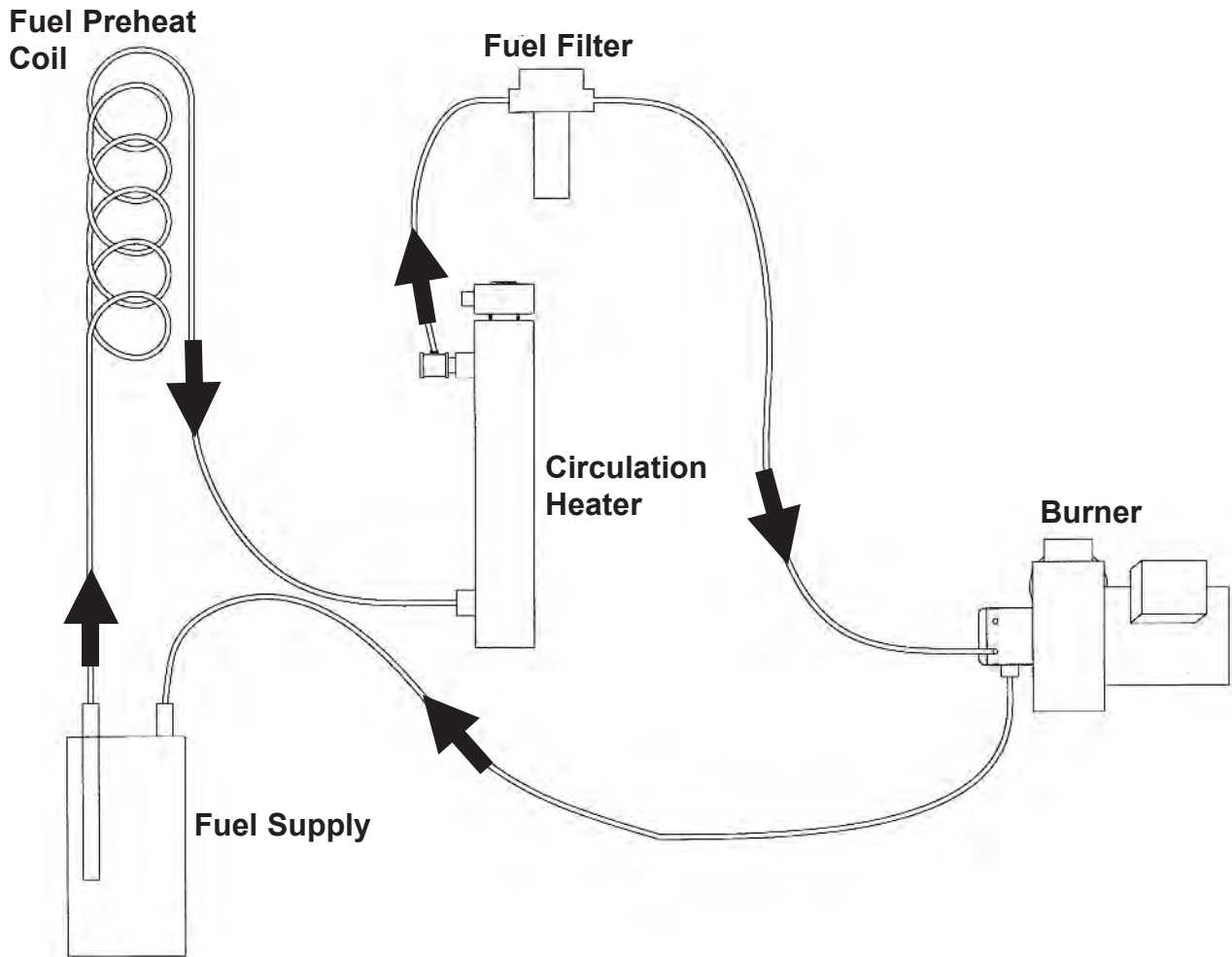

SENSOR RESISTANCE CHART

Degrees Farenheight	Degrees Celcius	Resistance (1K Ohm Scale)*	Degrees Farenheight	Degrees Celcius	Resistance (1K Ohm Scale)*
-40	-40	330.6	185	85	1.07
-31	-35	239	194	90	0.9156
-22	-30	174.7	203	95	0.7862
-13	-25	129	212	100	0.6777
-4	-20	96.21	221	105	0.5863
5	-15	72.42	230	110	0.5089
14	-10	55.01	239	115	0.4433
23	-5	42.14	248	120	0.3873
32	0	32.55	257	125	0.3395
41	5	25.34	266	130	0.2985
50	10	19.87	275	135	0.2633
59	15	15.7	284	140	0.2328
68	20	12.49	293	145	0.2065
77	25	10	302	150	0.1836
86	30	8.059	311	155	0.1636
95	35	6.534	320	160	0.1455
100	40	5.329	329	165	0.1303
113	45	4.371	338	170	0.1169
122	50	3.604	347	175	0.1052
131	55	2.988	356	180	0.09484
140	60	2.489	365	185	0.08569
149	65	2.084	374	190	0.07757
158	70	1.753	383	195	0.07037
167	75	1.481	392	200	0.06396
176	80	1.256			

* Correct Ohm reading when sensors are at the above listed temperatures

CONTROL BOX WIRING

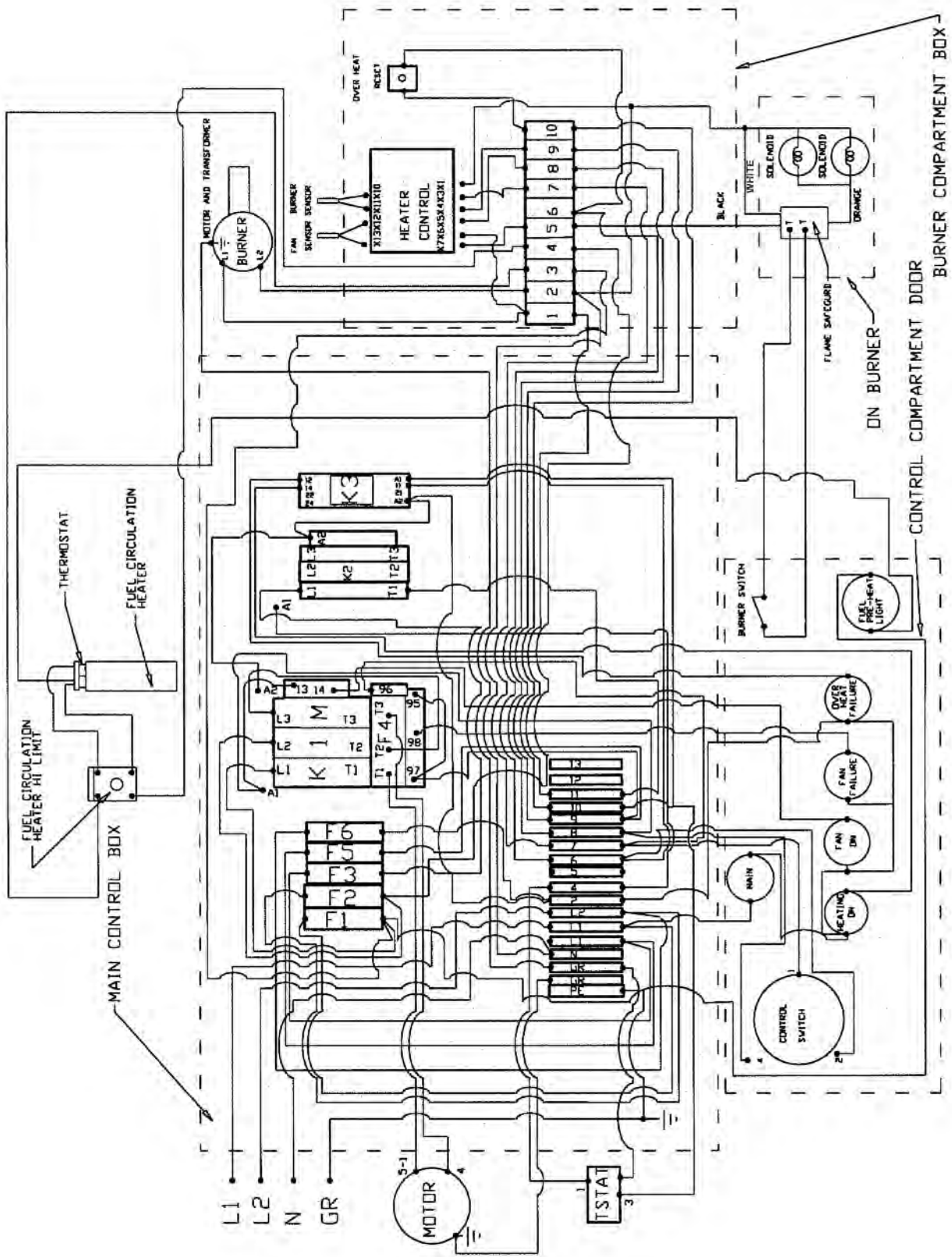

CONTROL BOX MAIN CIRCUIT DIAGRAM

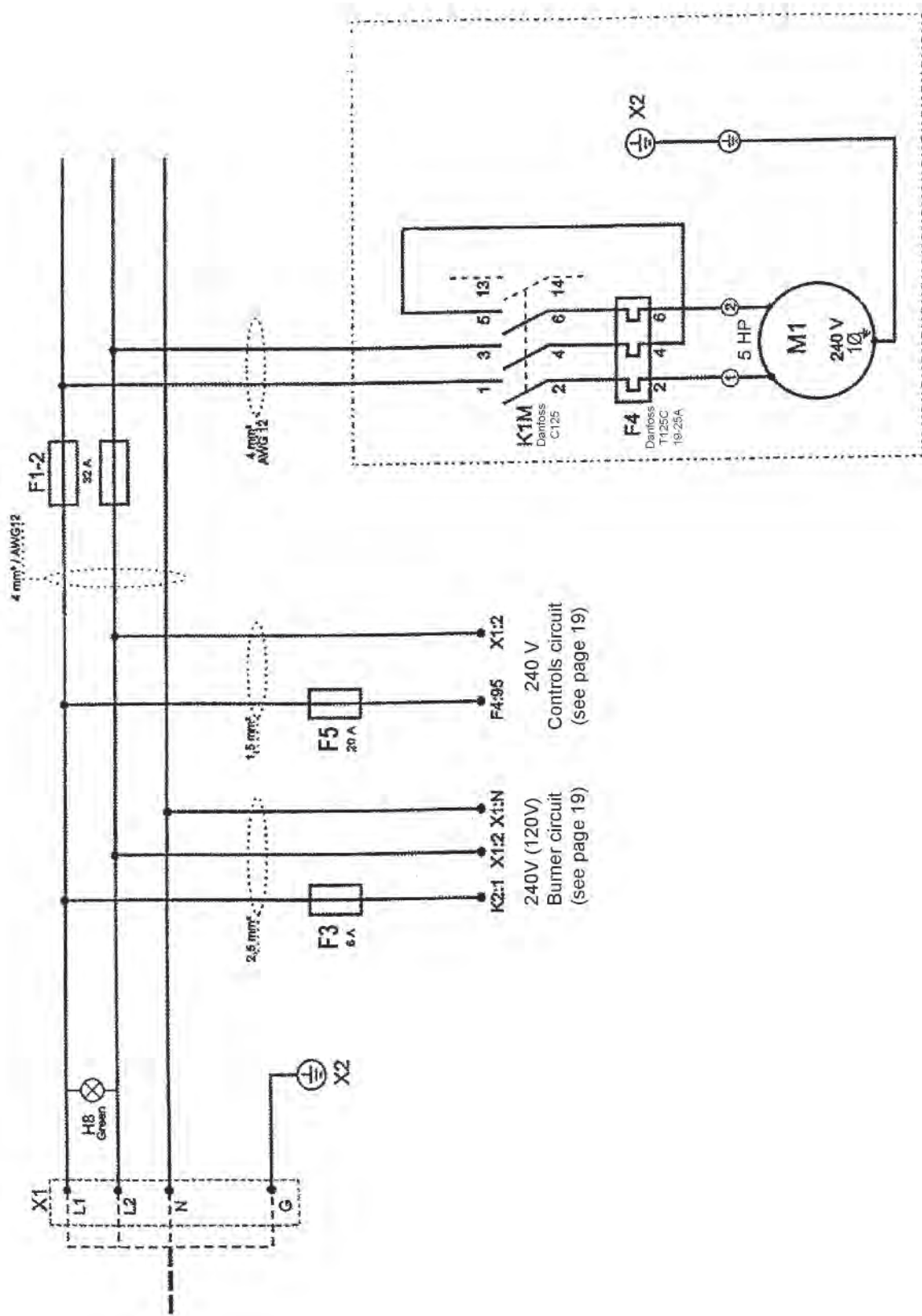

EXHAUST FLUE PIPE GUIDELINES

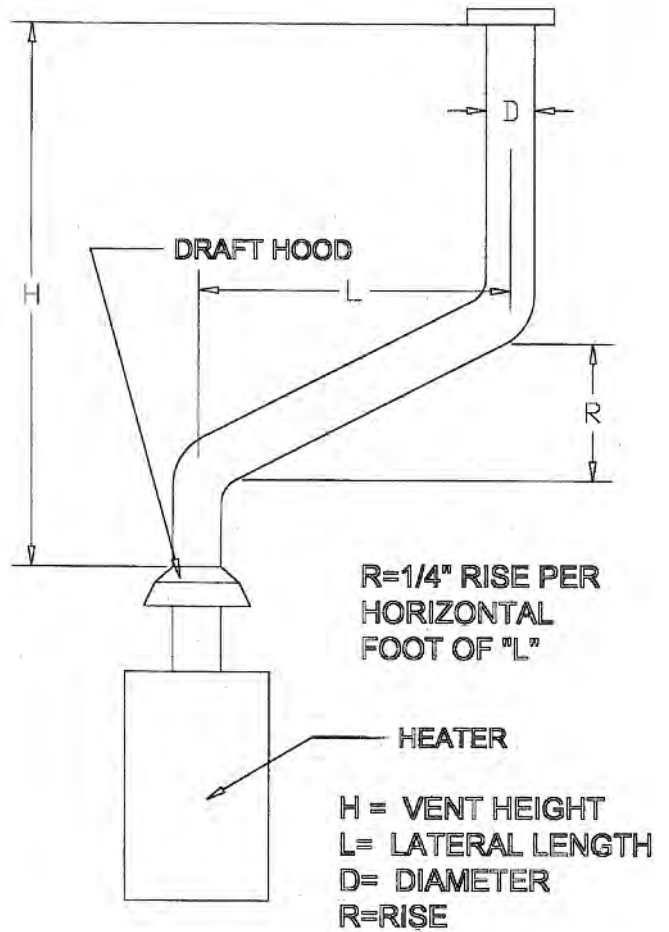
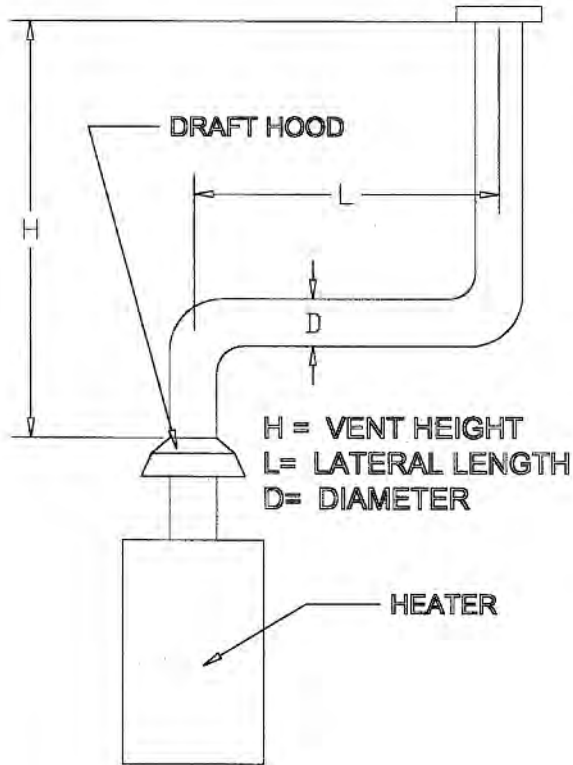

**CAPACITY OF
 TYPE B DOU-
 BLE-WALL
 VENTS SERVING
 A SINGLE DRAFT
 HOOD-HEATER
 x 1000 BTU'S**

**FOR INDOOR
 APPLICATIONS**

		VENT DIAMETER (D) INCHES							
		10	12	14	16	18	20	22	24
TOTAL VENT HEIGHT (H) FEET	LATERAL LENGTH (L) FEET								
6	0	NR	850	1170	1530	1960	2430	2950	3520
	2	NR	650	890	1170	1480	1850	2220	2670
	6	NR	630	870	1150	1470	1820	2210	2650
	12	NR	610	840	1110	1430	1795	2180	2600
8	0	NR	970	1320	1740	2220	2750	3360	4010
	2	NR	745	1020	1340	1700	2110	2560	3050
	8	NR	720	1000	1320	1670	2070	2530	3030
	16	NR	685	950	1260	1600	2035	2470	2960
10	0	NR	1060	1450	1925	2450	3050	3710	4450
	2	NR	850	1130	1480	1890	2340	2840	3390
	10	NR	795	1080	1430	1840	2280	2780	3340
	20	NR	735	1030	1360	1780	2230	2720	3250
15	0	NR	1240	1720	2270	2900	3620	4410	5300
	2	NR	985	1350	1770	2260	2800	3410	4080
	15	NR	905	1250	1675	2150	2700	3300	3980
	30	NR	845	1180	1550	2050	2620	3210	3840
20	0	NR	1350	1900	2520	3250	4060	4980	6000
	2	NR	1100	1520	2000	2570	3200	3910	4700
	10	NR	1045	1460	1940	2500	3130	3830	4600
	20	NR	990	1390	1880	2430	3050	3760	4550
30	30	NR	945	1270	1700	2330	2980	3650	4390
	0	1060	1550	2170	2920	3770	4750	5850	7060
	2	865	1310	1800	2380	3050	3810	4650	5600
	20	784	1185	1650	2200	2870	3650	4480	5310
	40	705	1075	1520	2060	2700	3480	4270	5140

Oil Fired Accessories



FT400-FUEL TANK

- 75 gallon tank
- Single wall tank
- Forklift capability from all four sides
- Use with VF400 heater
- Minimum 25 hour run time
- 160 lbs. (empty)
- 750 lbs. (full)



FT1000-FUEL TANK

- 340 gallon tank with fuel gauge
- Double wall tank
- Forklift capability from all four sides
- Use with VF1000 heater
- Minimum 47 hour run time
- 1,000 lbs. (empty)
- 3,800 lbs. (full)

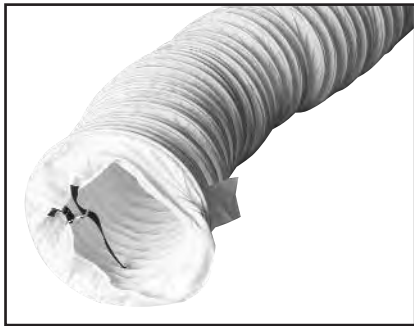

DUCTING



THERMOSTAT
LOCK BOXES



342 N. Co. Rd. 400 East

Valparaiso, IN 46383

219-464-8818 • Fax 219-462-7985

www.heatwagon.com