



342 N. Co. Rd. 400 East  
Valparaiso, IN 46383  
219-464-8818 • Fax 219-462-7985  
[www.heatwagon.com](http://www.heatwagon.com)

## Installation and Maintenance Manual

Please retain this manual for future reference.

# DG250/DG400

***Ductable  
Construction  
Heater***

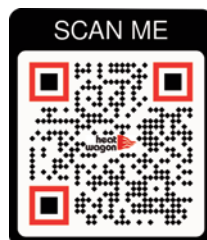

*For your safety: Do not use this heater in a space where gasoline or other liquids having flammable vapors are stored.*

### **WARNING**

BEFORE USING THE HEATER, READ AND UNDERSTAND ALL INSTRUCTIONS AND FOLLOW THEM CAREFULLY.

THE MANUFACTURER IS NOT RESPONSIBLE FOR DAMAGES TO GOODS OR PERSONS DUE TO IMPROPER USE OF THE UNITS.

### **GENERAL HAZARD WARNING**

FAILURE TO COMPLY WITH THE PRECAUTIONS AND INSTRUCTIONS PROVIDED WITH THIS HEATER, CAN RESULT IN DEATH, SERIOUS INJURY AND PROPERTY LOSS OR DAMAGE FROM HAZARDS OF FIRE, EXPLOSION, BURN, ASPHYXIATION, CARBON MONOXIDE POISONING, AND / OR ELECTRICAL SHOCK.

ONLY PERSONS WHO CAN UNDERSTAND AND FOLLOW THE INSTRUCTIONS SHOULD USE OR SERVICE THIS HEATER.

IF YOU NEED ASSISTANCE OR HEATER INFORMATION SUCH AS AN INSTRUCTION MANUAL, LABEL, ETC., CONTACT THE MANUFACTURER.

### **WARNING: FIRE, BURN, INHALATION AND EXPLOSION HAZARD**

KEEP SOLID COMBUSTIBLES, SUCH AS BUILDING MATERIALS, PAPER OR CARDBOARD, AT SAFE DISTANCE AWAY FROM THE HEATER AS RECOMMENDED BY THE INSTRUCTIONS.

NEVER USE THE HEATER IN SPACES WHICH DO OR MAY CONTAIN VOLATILE OR AIRBORNE COMBUSTIBLES, OR PRODUCTS SUCH AS GASOLINE, SOLVENTS, PAINT THINNER, DUST PARTICLES OR UNKNOWN CHEMICALS.

### **WARNING**

NOT FOR HOME OR RECREATIONAL VEHICLE USE. INSTALLATION OF THIS HEATER IN A HOME OR RECREATIONAL VEHICLE MAY RESULT IN A FIRE OR EXPLOSION, PROPERTY DAMAGE, PERSONAL INJURY OR LOSS OF FIRE.

### **WARNING**

IMPROPER INSTALLATION, ADJUSTMENT, ALTERATION, SERVICE OR MAINTENANCE CAN CAUSE INJURY OR DEATH.

READ THE INSTALLATION, OPERATING AND MAINTENANCE INSTRUCTIONS THOROUGHLY BEFORE INSTALLING OR SERVICING THIS EQUIPMENT.

### **FOR YOUR SAFETY**

IF YOU SMELL GAS:

1. OPEN WINDOWS
2. DO NOT TOUCH ELECTRICAL SWITCHES
3. EXTINGUISH ANY OPEN FLAME
4. IMMEDIATELY CALL YOUR GAS SUPPLIER

### **FOR YOUR SAFETY**

DO NOT STORE OR USE GASOLINE OR OTHER FLAMMABLE VAPOURS AND LIQUIDS IN THE VICINITY OF THIS OR ANY OTHER APPLIANCE.

### **WARNING**

The heater is designed and approved for use as a construction heater in accordance with Standard ANSI Z83,7 CGA 2.14.

CHECK WITH YOUR LOCAL FIRE SAFETY AUTHORITY IF YOU HAVE QUESTIONS ABOUT APPLICATIONS.

Other standards govern the use of fuel gases and heat producing products in specific applications. Your local authority can advise you about these.

### **WARNING**

This heater can be washed, provided that:



- A. The heater is disconnected from the electrical supply.
- B. All access panels are securely closed.
- C. Water spray nozzle shall not discharge within 6 feet of the heater.
- D. The heater is not reconnected to electrical supply until thoroughly dried.  
Improper cleaning of the heater can cause severe personal injury or property damage due to water and/or cleaning solutions:
  - A. In electrical components, connections and wires causing electrical shocks or component failure.
  - B. On gas control components causing corrosion which can result in gas leaks and fire or explosion from the leak. The hose assembly must be protected from the traffic, building materials and contact with hot surfaces both during use and while in storage.

### **WARNING**

- Proper gas supply must be provided to the inlet of the appliance.
- Refer to rating plate for proper gas supply pressure.
- Gas pressure in excess of maximum inlet pressure specified at the appliance inlet can cause fire or explosions, leading to serious injury, death, building damage or loss of livestock. Likewise, gas pressure below the minimum inlet pressure specified at the appliance inlet may cause improper combustion, leading to asphyxiation, carbon monoxide poisoning and therefore serious injury or death to humans and livestock.
- Position heater properly before use.
- For either indoor or outdoor use adequate ventilation must be provided.
- Minimum clearance from combustible materials and propane containers: 10 ft.
- Do not operate heater with panels removed.
- To avoid injury from moving parts, disconnect all electrical power to equipment before opening doors or removing panels.

RETAIN THIS INSTRUCTION FOR FUTURE REFERENCE.

**TAB 1**

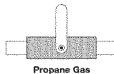
TECHNICAL SPECIFICATIONS			DG 250	DG 400	
Natural gas		Supply pressure	[in WC]	min 7" w.c. max 10" w.c.	min 7" w.c. max 10" w.c.
		Selector valve position			
	Normal altitude 0 - 2,000 ft above sea level (U.S.A. and Canada)	Heat input	[BTU/h]	254.684	403.753
		Manifold pressure	[in WC]	4,33	4,40
		Fuel consumption	[CFH]	241,52	381,35
	Altitude 2,000 - 4,500 ft above sea level	Heat input	[BTU/h]	229.216	363.378
		Manifold pressure	[in WC]	4,11	4,18
Fuel consumption		[CFH]	217,37	343,21	
<b>NOTE</b>		Supply pressure	[in WC]	min 8" w.c. max 13" w.c.	min 8" w.c. max 13" w.c.
L.P.G.		Selector valve position			
		Normal altitude 0 - 2,000 ft above sea level (U.S.A. and Canada)	Heat input	[BTU/h]	241.413
	Manifold pressure		[in WC]	4,28	4,50
	Fuel consumption		[CFH]	88,98	145,12
	Altitude 2,000 - 4,500 ft above sea level	Heat input	[BTU/h]	217.272	354.721
		Manifold pressure	[in WC]	4,06	4,27
		Fuel consumption	[CFH]	80,08	130,61
Air flow			[cfm]	2.766	4.120
Power supply	Phase			1	1
	Voltage		[V]	120	120
	Frequency		[Hz]	60	60
Electric consumption			[W]	500	900
			[A]	5,0	8,5
Ring nozzle			[in]	N. 16 holes x 0,079"	N. 16 holes x 0,102"
Gas inlet connection thread				3/4" NPT	3/4" NPT
Air distribution duct	Max Static pressure		[in]	0,60	0,56
	Max length		[ft]	50	50
Noise level at 1 m			[dBA]	77	74
Heater	Dimensions, L x W x H		[in]	40,6 x 24,6 x 21,7	56,,1 x 29,5 x 25,7
	Weight		[lb]	101	192
Packaging	Dimensions, L x W x H		[in]	42,3 x 21,9 x 29,45	57,7 x 24,4 x 32,6
	Weight		[lb]	134	225
Temp Rise				170°	180°
Recommended Duct				WD1625HT5	WD2025HT5
Duct Adaptor				AR250	AR400
Thermostat (confirm correct thermostat with serial number p.10-11)				DIGTHIDF-5 or DIGTHIDF	DIGTHIDF-5 or DIGTHIDF

## DESCRIPTION

The heater is designed for heating medium and large ventilated premises, for which a fixed or mobile heating system is required.

Heater is to be run on heating with natural gas or L.P.G. according to gas supply pressures that must be in conformity with the local codes.

Gases to be used are indicated in Tab. pg.4 together with the supply pressures, the regulation of the gas valves group (burner pressure) and gas flow.

Heater is supplied after a complete functional test and it's therefore prearranged for one of the working gas indicated in Tab. lpg.4 an adhesive label applied on the gas selector valve (a) indicates the selected gas.

To change the type of gas, follow the detailed instructions indicated in section "CHANGING TYPE OF GAS". (page 6)

The heater is of the direct combustion type. The air is heated by the energy developed during combustion and then conveyed to the environment to be heated together with the combustion products, thus making available 100% of the thermal power produced. The environment must be suitably ventilated in order to ensure adequate air circulation.

In the event of serious malfunction various safety devices (electronic flame control unit, overheating thermostat, air pressure switch) trigger turning off the heater .

The electronic flame control unit monitors if the flame is irregular or goes out, the safety thermostat triggers when the temperature in the combustion chamber exceeds the safety limit value, the air pressure switch will cut in if the airflow is insufficient.

In each of the said cases the unit stops according to the procedure described in "OPERATING INSTRUCTIONS".

In each of the said cases the lamp (8) will light up and the heater will stop working. The heater can be restarted only by pressing the reset button (8). Nonetheless, the cause that triggered the safety device should always be carefully analyzed and resolved before restarting the heater (see Troubleshooting Guide). pg.9

### Warning



**Check with your local fire safety authority if you have questions about applications**

Here are a few guidelines which shall be followed:

- Minimum clearances from combustible material must be:
  - 1 m (3 feet) from side and rear (air inlet) of heater
  - 0.7 m(2 feet) from ceiling
  - 3 m (10 feet) on air outlet of heater.
- Heater shall not be directed toward any propane-gas container within 6 m (20 feet)
- Don't install the heater in places where there may be a risk of fire or explosion
- All fire prevention regulations must be adhered to.
- For air distribution use only recommended duct from Heat Wagon and respect max length as declared in Tab. I
- The room or building which is being heated must be sufficiently ventilated so that the heater has enough air to function properly;
- The air suction and/or supply pipes are not blocked in any way, there are not sheets or covers resting on the machine or walls and bulky objects near the heater;
- The heater is placed near a power switchboard meeting electrical requirements. Tab 1, pg. 4
- The unit is placed in a fixed position;
- Make sure heater is inspected before each use, and at least annually by a qualified service person.
- Don't let animals or children near the heater.
- The heater is regularly monitored during operation and checked before being started up;
- After use make sure the disconnecting switch is off.

## INSTALLATION INSTRUCTION

### Warning



**All the operations described in this paragraph must be performed by professional and skilled personnel only**

The installation shall be in accordance with National Fuel Gas Code ANSI Z223.1/NFPA 54 and with CAN1-B149.1 Installation code.

**AN APPROVED MANUAL GAS VALVE SHALL BE PROVIDED BY THE INSTALLER.**

### Warning



**In case of installation in greenhouses, mechanical ventilation shall be interlocked to the heater operation or permanent openings shall be fixed for ventilation air.**

## ELECTRICAL CONNECTIONS

### Warning



**The power line of the heater must feature a ground and a residual current circuit breaker. The supply cable must be connected to a panel with a circuit breaker.**

### Warning



**When installed, the appliance must be electrically grounded in accordance with local codes, or in the absence of local codes, with the National Electrical Code, ANSI/NFPA 70, and/or the CSA C22.1, Canadian Electrical Code, if an external electrical source is utilized.**

The following operations must now be carried out:

- Plug in the power cord having read the rating plate that specify electric supply characteristics.
- **CONNECT THERMOSTAT (OPTIONAL) OR JUMPER PLUG TO THERMOSTAT RECEPTACLE. UNIT WILL NOT RUN WITHOUT ONE OF THESE ITEMS PLUGGED INTO RECEPTACLE.**

Having completed all these operations check carefully that all electrical connections correspond to the wiring diagram. When the heater is first turned on you must check that the fan does not use more current than the maximum permitted limit. We recommend a dedicated 15 amp circuit.

**NOTE: Max incoming gas pressure is 1/2 PSI (14" W.C.) recommend installation of install kit. Part# INSTKIT (optional)**

**See page 16.**

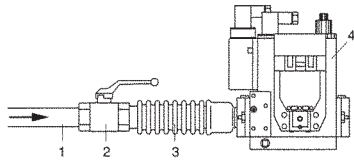

- 1 Main gas pipe
- 2 Manual shut-off valve
- 3 Antivibrating coupling
- 4 Gas valves group

**Fig. 3**

In case of connection of heater to natural gas, the installation shall conform with local codes or, in the absence of local codes, with the *National Fuel Gas Code ANSI Z223.1/NFPA 54 and the Natural Gas and Propane Installation Code, CSAB149.1*.

In case of connection to a propane supply cylinder:

- (a) the installation must conform with local codes or, in the absence of local codes, with the Standard for the *Storage and Handling of Liquefied Petroleum Gases, ANSI/NFPA 58 and the Natural Gas and Propane Installation Code, CSA B149.1*.
- (b) to determine size and capacity of the cylinder(s) and for any specific requirements consult your LP gas supplier. In any case propane tank should not be lower than 100 lb (90 liters)
- (c) the cylinder supply system shall be arranged to provide for vapour withdrawal from the operating cylinder;
- (d) the gas shall be turned off at the propane supply cylinder when the heater is not in use;
- (e) when the heater is to be stored indoors, the connection between the propane supply cylinder and the heater must be disconnected and the cylinders removed from the heater and stored in accordance with Standard for the *Storage and Handling of Liquefied Petroleum Gases, ANSI/NFPA 58 and CSA B149.1, Natural Gas and Propane Installation Code*.

The appliance must be isolated from the gas supply piping system by closing its individual manual shut-off valve during any pressure testing of the gas supply piping system at test pressures equal or less than 1/2 psi (3.5 kPa).

**STARTUP**

The heater is tested and set-up for one of the gas (natural or L.P.G.) indicated in Tab. I: an adhesive label applied on the manual gas selector valve (Fig. 4) indicates the working gas (usually it's natural gas). Should it necessary to change the kind of gas (from natural gas to L.P.G or viceversa) follow the detailed instructions indicated in section "CHANGING TYPE OF GAS".

Only when the heater has been set-up to the proper gas will it be possible to carry out the following operations:

- Bleed away some gas from the feed pipe;
- Check that the pipe is not leaking;
- Open the gas stopcock and start the heater;

For installation in the U.S.A. at elevation above 2,000 feet (610 m), the appliance shall be derated 4 per cent for each 1,000 feet (305 m) of elevation above sea level.

For installation in Canada at elevation above 2,000 feet to 4,500 feet above sea level, the heater is derated reducing the input for the appropriate fuel in accordance with the rating plate manifold pressure.

For installation in Canada at elevation above 4,500 feet above sea level, consult Provincial or Territorial Authorities having jurisdiction.

**Warning**

**STOP** THE CONVERSION SHALL BE CARRIED OUT BY A MANUFACTURER'S AUTHORIZED REPRESENTATIVE, IN ACCORDANCE WITH THE REQUIREMENTS OF THE MANUFACTURER, PROVINCIAL OR TERRITORIAL AUTHORITIES HAVING JURISDICTION AND IN

**ACCORDANCE WITH THE REQUIREMENTS OF THE CAN/CGA-B149.1 OR CAN/CGAB149.2 INSTALLATION CODES.**

A conversion label shall be applied adjacent to the Rating Label:

THIS APPLIANCE HAS BEEN CONVERTED FOR USE AT AN ALTITUDE OF \_\_\_\_\_ FEET (ABOVE 2000 FEET)

Orifice size: \_\_\_\_\_  
 Manifold pressure: \_\_\_\_\_  
 Input rate: \_\_\_\_\_  
 Date of conversion: \_\_\_\_\_  
 Type of fuel: \_\_\_\_\_  
 Converted by: \_\_\_\_\_

**CHANGING TYPE OF GAS**

This operation may be carried out several times during the working life of the machine and not only at initial start-up. Therefore, first of all check the adhesive label attached to the manual gas selector valve (a) in Fig. (2) to establish the original category of the gas and then consult Tab. I to identify the supply pressure, the working pressure, the use conditions of manual valve.

To change kind of gas it is necessary (Fig. 2): Pg. 8

- to remove the sticker on the manual gas selector valve stating the gas used at that time,
- to remove the screw under the sticker and turn the manual handle on the correct side according to the condition described in Tab.I and by following instruction:

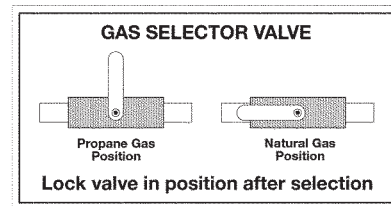

**Fig. 4**

- After having moved the handle into the opposite position, again put the fixing screw and a new sticker on it, stating the gas which has to be used (a number of different stickers are supplied with the machine)

**Warning**

**STOP** Burner pressure shall not be adjusted: the heater is ready to run on the new gas

Should it necessary to check the burner pressure:

- connect a gauge to the pressure port (b) Pg. 8
- carry out the pressure reading on the gauge and turn the pressure regulator (c) if necessary to obtain the correct burner pressure value indicated in Tab. I

**OPERATING INSTRUCTIONS**

**Warning**

**STOP** Any time the power cord of the heaters is connected to a receptacle check the polarity of power supply:

- check switch (9) and (13) are on "0"
- connect plug to receptacle
- push button (14): if it lights up, then reverse polarity

**Warning**

**STOP** If the correspondance of phase / neutral polarity is not correct, the unit may stop in the reset mode.

## HEATING MODE

### Turning ON

- Make sure switch (Item 9, Fig. 1) is on "0";
- Power the heater by plugging the unit into the supply line;
- If the unit is operated manually (without any thermostat or any other control device) turn the switch (9) to position "1". The burner starts up, the combustion chamber heats up and then the fan starts; Note: Jumper plug must be installed.
- If the unit is operated with (DIGTHIDF) thermostat turn the switch (9) to position "1" and set the thermostat at the desired level: the heater will now start and stop automatically.
- If after these operations, the heater does not work, refer to the Troubleshooting Guide paragraph page 9 and find the cause.

### Setting Post Ventilation Mode

By the switch (13) on control panel, select the post-ventilation mode, that is the time the fan goes on blowing air when unit is switched off:

- when switch (13) is on pos. "0" then postventilation lasts for 30 sec.
- when switch (13) is on pos. "1" then postventilation is continuous.

### Turning OFF

In manual operation turn switch (9) to "0" or turn thermostat control knob off.

After switching off the machine, a post ventilation function works according to the previous setting.

## DO NOT UNPLUG TO STOP HEATER!

### Warning



Finally, close the gas supply stopcock, close the shut-off valve (f) and turn off the sectioning switch (Fig. 1-2).

## VENTILATION MODE

To obtain the ventilation function only, make sure switch (9) is on position "0" and then simply turn the switch (14) to position "1". To stop it, turn the switch 14 to position "0". Pg. 8

### Warning



Whichever be the reason, the unit try to restart once. If the cause of malfunction remains, the unit definitely stop and lamp (8) will light up

The heater can be restarted only by pressing the reset button (8). Note: See Diagnostics on page 9.

Nonetheless, the cause that triggered the safety device should always be carefully analyzed and resolved before restarting the heater (See Troubleshooting Guide page 9).

## TRANSPORT AND HANDLING

### Warning



Before moving the unit:

- Stop the machine as indicated in HEATING MODE section (Turning OFF)
- Disengage the power supply by removing the plug from the power socket;
- Fully unscrew the fitting connecting the gas hose pipe to the heater;
- Wait for the heater to cool down.

The heaters with wheels must be wheeled.

## MAINTENANCE

To regulate operation of the unit, the fan, combustion chamber and the burner must be at least annually inspected and periodically cleaned by a qualified service person.

### Warning



Before performing any maintenance operation:

- Stop the machine as indicated in HEATING MODE section (Turning OFF)
- Disengage the power supply by removing the plug from the power socket;
- Close the gas supply stopcock and shut-off valve (f);
- Wait for the heater to cool down.

During cleaning any foreign bodies must be removed from the fan suction grille.

To access the burner, remove the flame guard panel (Item 4, Fig. 1) by removing the four screws and clean carefully inside the combustion chamber and the whole burner head: any debris shall be taken away.

### Warning



Do not direct jets of compressed air towards the air pressure points near the main fan: the air pressure switch could be permanently damaged.

Cleaning of the burner shall be regularly performed by qualified service person. To access the burner, remove the flame guard shield of combustion chamber (front side) and clean carefully inside the combustion chamber and the whole burner head and electrodes.

### Warning



After cleaning, the flame guard panel of combustion chamber (4) must be put back in place and secured with the relative screws before operate the heater.

Operating the heater without the flame guard panel of combustion chamber (4) can cause the flame to work with risk to the health of exposed persons (because of formation of carbon monoxide, CO) and constituting a danger for the environment.

VAPORIZATION RATES IN BTUH @ 0 DEG. F							
TANK SIZE	NUMBER OF TANKS MANIFOLDED	PERCENTAGE OF TANK FILLED					
		10%	20%	30%	40%	50%	60%
250	1	126,900	169,200	197,400	225,600	253,800	282,000
	2	279,180	372,240	434,280	496,320	558,360	620,400
	3	486,027	648,036	756,042	864,048	972,054	1,080,060
500	1	198,135	264,180	308,212	352,240	396,270	440,300
	2	435,897	581,196	687,066	774,928	871,794	968,660
	3	758,857	1,011,809	1,180,451	1,349,079	1,517,714	1,686,349
1000	1	354,240	472,320	551,040	629,760	708,480	787,200
	2	779,328	1,039,104	1,212,288	1,385,472	1,558,656	1,731,840
	3	1,356,739	1,808,985	2,110,483	2,411,980	2,713,478	3,014,976

NOTE: USE FOLLOWING MULTIPLIERS FOR OTHER AIR TEMPERATURES

- For -10° F multiply x 0.50
- For + 10°F multiply x 1.5
- For +20°F multiply x 2.0
- For +40°F multiply x 3.0
- For +50°F multiply x 3.5
- For +60°F multiply x 4.0

Hose Length in Feet	BTU 400,000					Hose Length in Feet	BTU 400,000			
	1/2PSI	10PSI					1/2PSI	1PSI	2PSI	5PSI
10	3/4	3/8				10	1	3/4	3/4	3/4
25	1	3/8				25	1-1/4	3/4	3/4	3/4
35	1	3/8				35	1-1/4	3/4	3/4	3/4
50	1-1/4	3/8				50	1-1/4	3/4	3/4	3/4
75	1-1/4	1/2				75	1-1/2	3/4	3/4	3/4
100	1-1/4	1/2				100	1-1/2	3/4	3/4	3/4
125	1-1/4	1/2				125	1-1/2	1	3/4	3/4
150	1-1/4	1/2				150	2	1	3/4	3/4
175	1-1/2	3/4				175	2	1-1/4	3/4	3/4
200	1-1/2	3/4				200	2	1-1/4	3/4	3/4
225	1-1/2	3/4				225	2	1-1/4	3/4	3/4

**VAPOR PROPANE QUICK  
REFERENCE HOSE  
CHART**

**NATURAL GAS QUICK  
REFERENCE HOSE  
CHART**

**CONTROL PANEL**

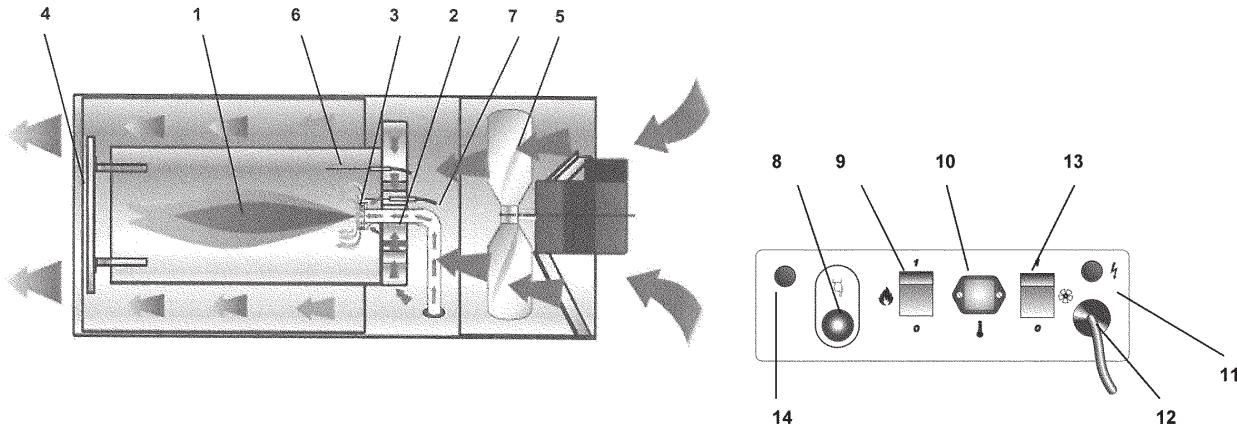

Fig. 1

- 1 COMBUSTION CHAMBER
- 2 BURNER
- 3 DIFFUSION RING
- 4 FLAME GUARD SHIELD
- 5 COOLING FAN
- 6 IONIZATION ELECTRODE
- 7 IGNITION ELECTRODE
- 8 CONTROL FLAME ELECTRONIC RESET
- 9 HEATING SWITCH (see Heating Mode, Page 7)
- 10 ROOM THERMOSTAT PLUG
- 11 POWER CONTROL LAMP
- 12 POWER CORD
- 13 VENTILATION MODE SWITCH (see Heating Mode, Page 7)
- 14 PHASE / NEUTRAL LINE TEST PUSH BUTTON (Reverse Polarity)

**MANIFOLD ASSEMBLY**

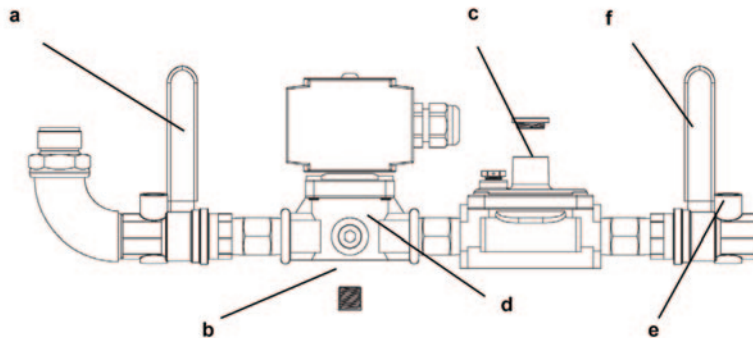

Fig. 2

- a GAS SELECTOR VALVE
- b MANIFOLD PRESSURE PORT (MANIFOLD)
- c MANIFOLD PRESSURE REGULATOR
- d MAIN GAS VALVE
- e INLET PRESSURE PORT
- f SHUT OFF / FIRING VALVE



## TROUBLESHOOTING GUIDE

FAULTS	CAUSES	REMEDIES
• The heater fails to start/ignite	• No power supply	<ul style="list-style-type: none"> <li>• Check power specifications</li> <li>• Check power connections</li> <li>• Check fuse integrity</li> </ul>
	• Main switch in wrong position	• Select correct position
	• Faulty operation of room thermostat Connect thermostat (optional) or blind plug to thermostat receptacle. Unit will not run without one of these items plugged into receptacle.	• Check thermostat position (Confirm "H" Mode)
	• Defective transformer or electronic control unit	• Call Tech Service
	• The duct gives too much back pressure and airpressure switch PA1 blocks the heater	• Reduce back pressure by straightening the duct or by reducing duct length
	• Control board or overheat limit needs reset	• Push button to reset (see below)
• The heater stops and the indicator light (1) comes on	• Gas pressure switch trips due to interruption of gas flow (gas pressure switch electric contact does not close during operation)	<ul style="list-style-type: none"> <li>• Make sure the gas supply hose has been bled</li> <li>• Check gas supply pressure</li> </ul>
	• The flame sensor is not operating correctly	• Remove the flame sensor and clean
	• The safety thermostat trips due to overheating of the combustion chamber (the thermostat electrical contact does not close during operation)	<ul style="list-style-type: none"> <li>• Make sure the suction and feed grilles are not blocked</li> <li>• Make sure the environment is well ventilated</li> <li>• Confirm correct supply &amp; manifold gas pressure</li> <li>• Make sure the warm air can exit freely</li> </ul>
	• Control unit trips due to irregular operation of burner	• Call Tech Service
	• Faulty air switches	• Check the air switch, filter & tube, replace if defective
	• Faulty electronic control unit	• Call Tech Service
	• Faulty thermostat	• Check the thermostat and, if necessary, replace
	• Fan noise or vibrations	• Foreign bodies on fan blades
• Little air circulation		• Eliminate and obstacles to proper air flow

### DIAGNOSTICS

If the control unit is in lockout status, by keeping the reset push-button (on-board or remote) pressed for 10+ seconds the diagnostics routine will be activated and the cause leading to the lockout condition will be displayed. Pressing the reset push-button again for 3+ seconds enables to reset the device and to terminate the diagnostics routine.

The following table shows a description of the diagnostics messages:

No. of blinks (red LED or LO output)	Description
2	Flame failure at the end of TS
3	Air pressure switch does not close
4	Extraneous light / flame simulation at start-up
5	Air pressure switch failure to open during start-up
6	Air pressure switch failure in running status
7	Flame failure in running status
9-14	Internal failure

### SIGNALLING DURING OPERATION

In the various operating conditions, the device can signal its operating status by means of a multicolour LED located on the on-board lockout signal. The meaning of the colours is the following:





	Stable green: Pre-purge (TP) – Ignition (TS) – Running status (RP)
	Discontinuous orange (1s ON – 1s OFF): Low-voltage condition detected, waiting for supply voltage restoration
	Stable red: Lockout status (LO)
	Off: Stand-by status (SY)

Fig. 5 – Meaning of LED signals

# Wiring Diagram

For model DG250, starting from SN 43300101

For model DG400, starting from SN 43400201

Note: 5 pin thermostat plug

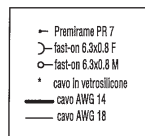
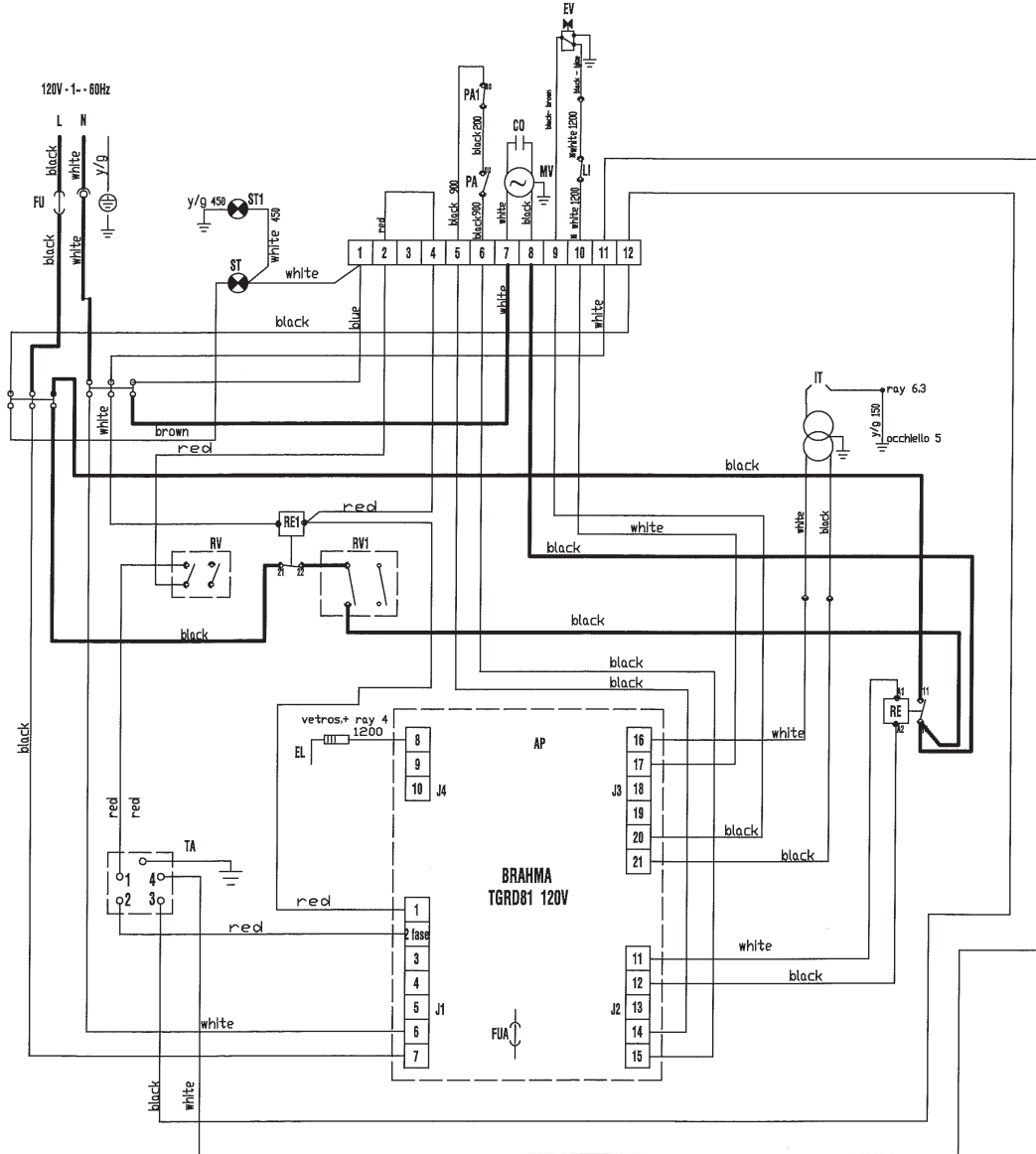

- |  |  |
|--|--|
| <b>AP</b> Control box                          | <b>CO</b> Condenser                            |
| <b>TA</b> Room thermostat plug                 | <b>MV</b> Fan motor                            |
| <b>ST</b> Electric pilot lamp                  | <b>FUA</b> Fuse P/N - BIE E10325               |
| <b>ST1</b> Polarity pilot lamp                 | <b>FV</b> Fuse 20A                             |
| <b>FU</b> Fuse 20A                             | <b>IT</b> Transformer H.V.                     |
| <b>IT</b> Transformer H.V.                     | <b>EV</b> Gas train                            |
| <b>EV</b> Gas train                            | <b>EL</b> Ionisation electrode                 |
| <b>EL</b> Ionisation electrode                 | <b>PA</b> Air pressure switch                  |
| <b>PA</b> Air pressure switch                  | <b>PA1</b> Air pressure switch Presostato aire |
| <b>PA1</b> Air pressure switch Presostato aire | <b>CO</b> Condenser                            |
| <b>CO</b> Condenser                            | <b>MV</b> Fan motor                            |
| <b>MV</b> Fan motor                            | <b>RE</b> Fan motor relay                      |
| <b>RE</b> Fan motor relay                      | <b>RE1</b> No stop ventilation relay           |
| <b>RE1</b> No stop ventilation relay           | <b>RE2</b> Delay starting relay Optional       |
| <b>RE2</b> Delay starting relay Optional       | <b>R</b> Anti moisture resistance Optional     |
| <b>R</b> Anti moisture resistance Optional     |  |

# Wiring Diagram

For model DG250, prior to SN 43303001

For model DG400, prior to SN 43403001

Note: 4 pin thermostat plug

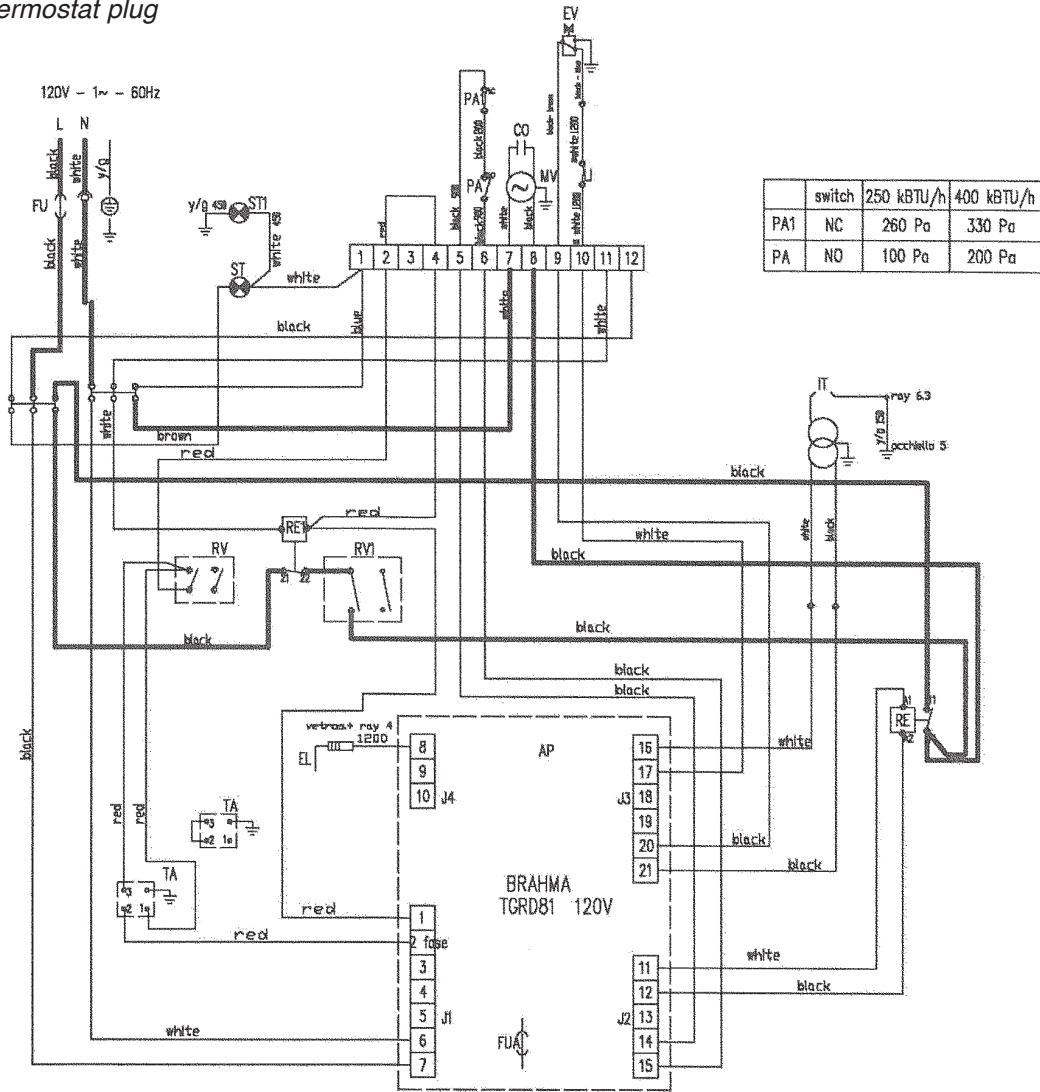

- AP CONTROL BOX
- FU FUSE
- EL IONIZATION ELECTRODE
- FUA FUSE P/N - E10325
- LI OVERHEAT THEMOSTAT
- PA PRESSURE SWITCH (2)
- TA ROOM THERMOSTAT PLUG
- IT TRANSFORMER H.T.
- CO CAPACITOR
- RV HEATING SWITCH

- RE MOTOR RELAY
- ST CONTROL LAMP
- EV GAS TRAIN
- MV COOLING MOTOR
- RV1 VENTILATION MODE SWITCH
- RE1 POST-VENTILATION RELAY

# DG250 Parts Breakdown

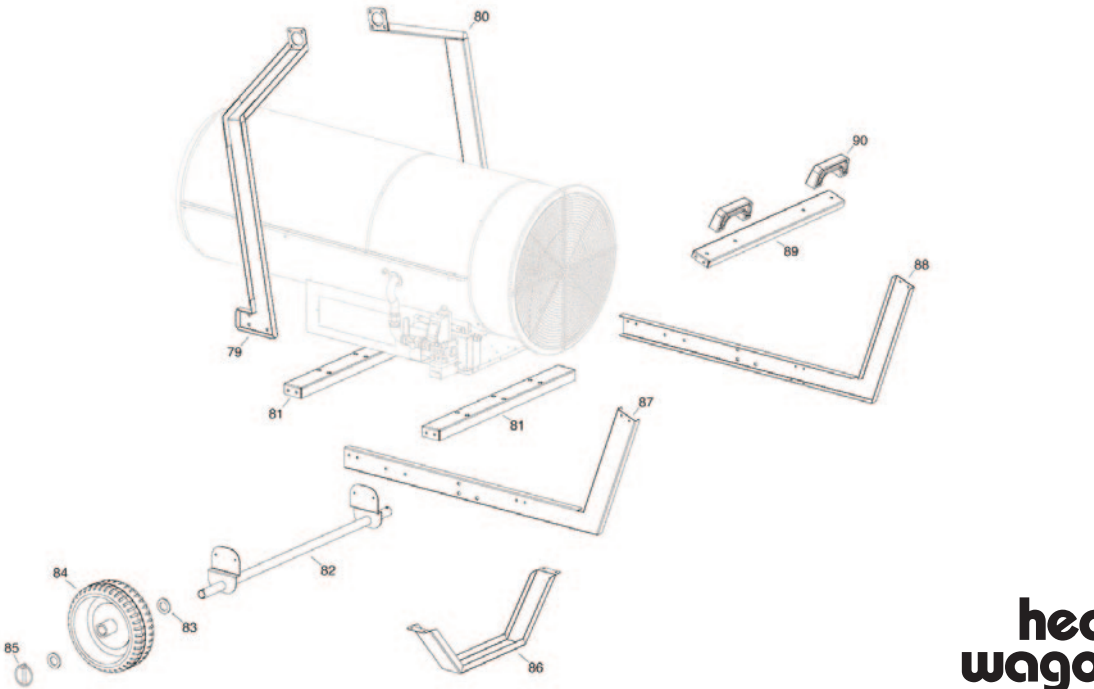
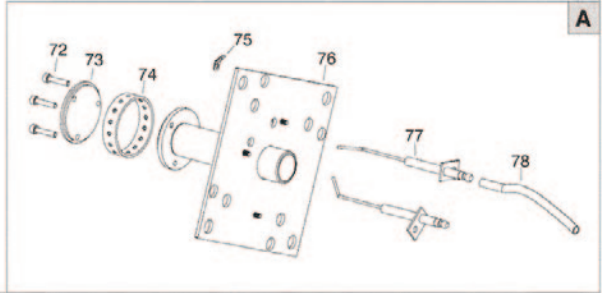
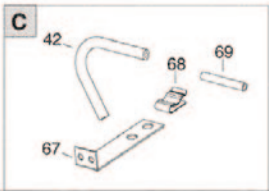
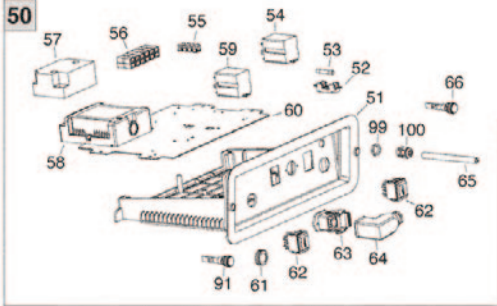
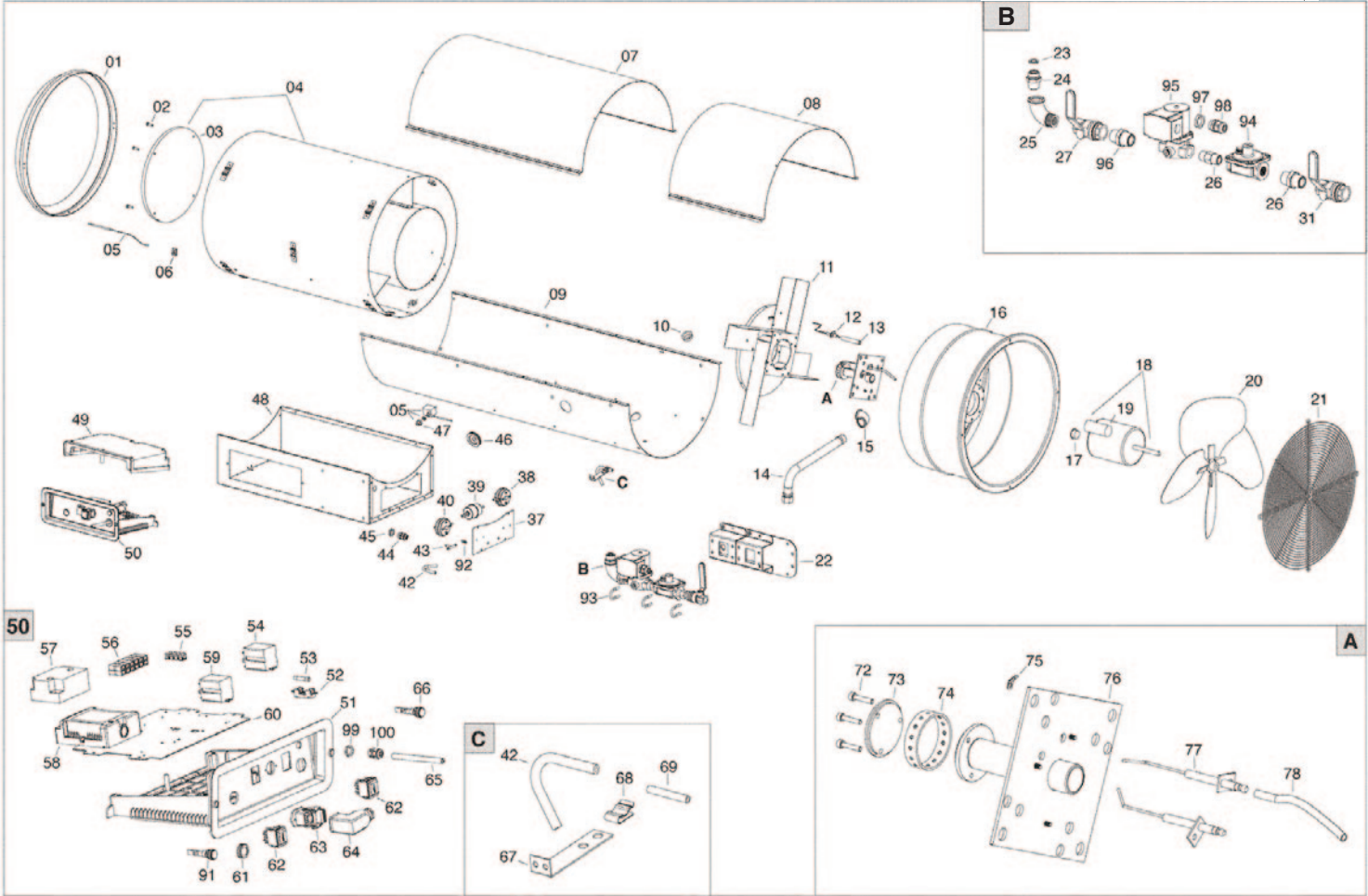
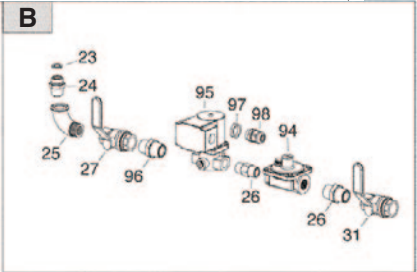
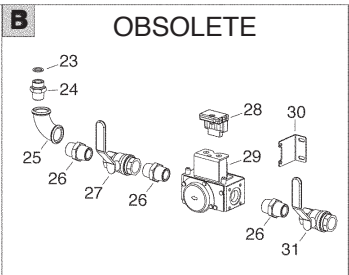

## DG250 Parts List

POS	P/N	DESCRIPTION	POS	P/N	DESCRIPTION
01	BIE G03146-9005	Outlet cone	62	BIE E10110-1-P	Switch
02	BIE M10203/1/B	Screw	63	BIE E20639	Plug housing - 5 pin, female
03	BIE G03113	Front disc		BIE E20640	Plug housing - 4 pin, female
04	BIE G03148	Combustion chamber	64	BIE E20966	Plug with jumper - 5 pin
05	BIE E50745	Safety thermostat		BIE E20675	Plug with jumper - 4 pin
06	BIE M20413	Hose bracket	65	BIE E30443	Power cord
07	BIE G03149-9010	Upper body		BIE E30443-1	Power cord (used with cable nut)
08	BIE G03151-9010	Inspection panel	66	BIE E11030	Lamp
09	BIE G03153-9010	Lower body	67	BIE G03144-X	Stirrup
10	BIE C30372	Cable protection	68	BIE M20413	Hose bracket
11	BIE G03155	Rear disc	69	BIE I40303	Pipe
12	BIE E10245	Ionisation electrode	72	BIE M10323/1	Screw
13	BIE I40332	Silicone pipe	73	BIE GA.0010208	Burner disc
14	BIE I39106	Flex gas pipe	74	BIE GA.0110205	Diffuser ring
15	BIE I20326	Fitting	75	BIE E20679	Terminal board
16	BIE G06125-9005	Air conveyor	76	BIE G03129	Burner support plate
17	BIE C30374	Pipe cap	77	BIE E10215	Ignition electrode
18	BIE E10678-110	Motor - AACO	78	BIE G02078	H.T. Cable connect.
	BIE E10771	Motor - Simel	79	BIE G03160-9005	Lifting bracket
19	BIE E11230	Capacitor - For AACO motor (40mf)	80	BIE G03161-9005	Lifting bracket
	BIE E10771-1	Capacitor - For Simel motor (30mf)	81	BIE G03162-9005	Frame
20	BIE T10260	Fan	82	BIE G03163-9005	Wheel axle
21	BIE P30169	Inlet grill	83	BIE M20111	Washer
22	BIE G03414-9005	Valve support plate	84	BIE C10556	Wheel - Air filled
23	BIE I39102	Seal		BIE C10510	Wheel - Hard rubber
24	BIE I31205-1	Fitting	85	BIE M20505	Latched pin
25	BIE I20327	Fitting	86	BIE G03164-9005	Support
26	BIE I31209-1	Fitting	87	BIE G03165-9005	Frame
27	BIE T30330-3	Gas selector valve	88	BIE G03166-9005	Frame
31	BIE T30349	Gas manual valve	89	BIE G03167-9005	Handle plate
37	BIE G03156-9010	Pressure switch support bracket	90	BIE C10203	Handle
38	BIE E50444	Pressure switch 260 Pa	91	BIE E11021	Lamp
39	BIE I30414	Filter	92	BIE I31131	Brass hose connection
40	BIE E50440	Pressure switch 100Pa	93	BIE I31132	Brass hose connection
42	BIE I40335	Silicone pipe 39"	94	BIE T30119	Regulator
43	BIE I20669	Hose connection	95	BIE T30118	Gas valve unit
44	BIE E20952	Cable fastener	96	BIE I20335	Fitting
45	BIE E20955	Cable fastener nut	97	BIE E20950	Fastener nut
46	BIE C30376	Cable protection	98	BIE E20949	Cable fastener
47	BIE E50750	Safety thermostat plastic profile	99	BIE E20965	Cable nut
48	BIE G03158-9010	Base	100	BIE E20964	Cable fastener
49	BIE P50127	Control box cover			
50	BIE G00375-5P	El. control box - with 5 pin T-stat receptacle			
	BIE G00287	El. control box - with 4 pin T-stat receptacle			
51	BIE G03176	El. control box panel			
52	BIE E20508	Fuse holder			
53	BIE E10323	Fuse			
54	BIE E11153	Relay			
55	BIE E20319	Ground terminal board			
56	BIE E20305	Terminal board			
57	BIE E10931	H.T. Transformer			
58	BIE E40229	Flame control box			
59	BIE E11125	Relay			
60	BIE G06073	Support plate			
61	BIE E20418	Stop button protection			

*NOTE: Not shown*

*Fuse for Flame Control Box - BIE E10325 6.3A Slow blow*

### Optional Thermostat (5 Pin)

HWP DIGTHIDF-5	Optional thermostat with 50' cord
HWP 7979K24	5 pin plug insert
HWP 7979K32	5 pin plug cover

# DG400 Parts Breakdown

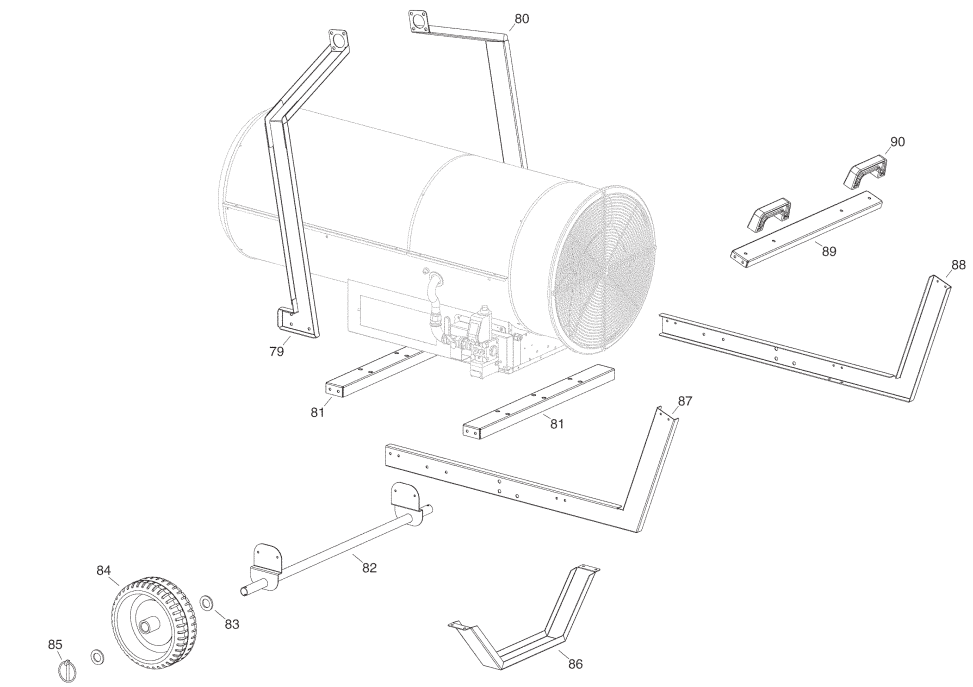
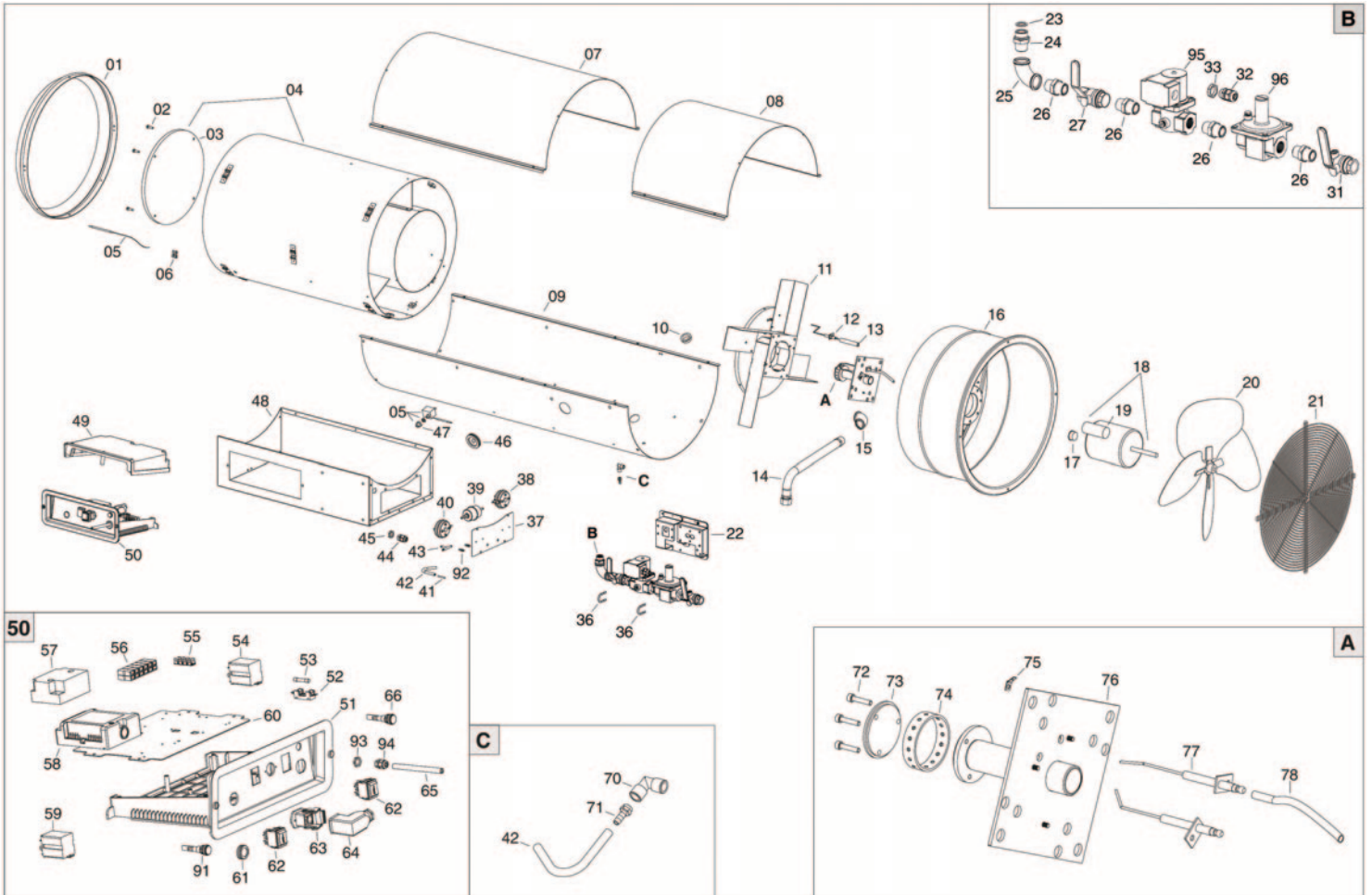

## DG400 Parts List

POS	P/N	DESCRIPTION			
01	BIE G06139-9005	Outlet cone	61	BIE E20418	Stop button protection
02	BIE M10203/1/B	Screw	62	BIE E10110-1-P	Switch
03	BIE G03114	Front disc	63	BIE E20639	Plug housing - 5 pin female
04	BIE G03147	Combustion chamber		BIE E20640	Plug housing - 4 pin female
05	BIE E50745	Safety thermostat	64	BIE E20966	Plug with jumper - 5 pin
06	BIE M20413	Hose bracket		BIE E20675	Plug with jumper - 4 pin
07	BIE G03150-9010	Lower body	65	BIE E30443	Power cord
08	BIE G03152-9010	Inspection panel		BIE E30443-1	Power cord - used with cable nut
09	BIE G03154-9010	Lower body	66	BIE E11030	Lamp
10	BIE C30372	Cable protection	70	BIE I20325	Fitting
11	BIE G03126	Rear disc	71	BIE I31130	Brass hose connection
12	BIE GA.0100206	Ionisation electrode	72	BIE M10323/1	Screw
13	BIE I40332	Silicone pipe	73	BIE GA.0010208	Burner disc
14	BIE I39106	Flex gas pipe	74	BIE GA.0100204	Diffuser ring
15	BIE I20326	Fitting	75	BIE E20679	Terminal board
16	BIE G06239-9010	Air conveyor	76	BIE G03129	Burner support plate
17	BIE C30374	Pipe cap	77	BIE E10215	Ignition electrode
18	BIE E10704-110	Motor - AACO 80uF	78	BIE G02078	H.T. Cable connection
	BIE E10772	Motor - Simel 100uF	79	BIE G03168-9005	Lifting bracket
19	BIE E11249	Capacitor - For AACO motor (80mf)	80	BIE G03169-9005	Lifting bracket
	BIE E10772-1	Capacitor - For Simel motor (100mf)	81	BIE G03170-9005	Frame
20	BIE T10261	Fan	82	BIE G03171-9005	Wheel axle
21	BIE P30129	Inlet grill	83	BIE M20111	Washer
22	BIE G06460-3001	Valve support plate	84	BIE C10556	Wheel - Air filled
23	BIE I39102	Seal		BIE C10510	Wheel - Hard rubber
24	BIE I31205-1	Fitting	85	BIE M20505	Latched pin
25	BIE I20326	Fitting	86	BIE G03172-9005	Support
26	BIE I31204	Fitting	87	BIE G03173-9005	Frame
27	BIE T30330-2	Gas selector valve	88	BIE G03174-9005	Frame
31	BIE T30333	Gas manual valve	89	BIE G03175-9005	Handle plate
32	BIE E20949	Cable fastener	90	BIE C10203	Handle
33	BIE E20950	Cable fastener nut	91	BIE E11021	Lamp
36	BIE M20907	Stirrup	92	BIE I31131	Brass hose connection
37	BIE G03157-9010	Pressure switch support bracket	93	BIE E20965	Cable nut-units SN 43400232 and beyond
38	BIE E50443	Pressure switch 330 Pa	94	BIE E20964	Cable fastener-units SN 43400232 and beyond
39	BIE I30414	Filter	95	BIE T30115	Gas valve unit
40	BIE E50441	Pressure switch 200 Pa	96	BIE T30116	Pressure regulator
41	BIE I40336	Rilsan pipe 39"			
42	BIE I40335	Silicone pipe 39"			
43	BIE I20669	Hose connection			
44	BIE E20952	Cable fastener			
45	BIE E20955	Cable fastener nut			
46	BIE C30376	Cable protection			
47	BIE E50750	Safety thermostat plastic profile			
48	BIE G03159-9010	Base			
49	BIE P50127	Control box cover			
50	BIE G00286-5P	El. control box - for 5 pin T-stat			
	BIE G00286	El. comp. drawer - for 4 pin T-stat			
51	BIE G03176	El. control box panel			
52	BIE E20508	Fuse holder			
53	BIE E10313	Fuse			
54	BIE E11153	Relay			
55	BIE E20319	Ground terminal board			
56	BIE E20305	Terminal board			
57	BIE E10931	H.T. Transformer			
58	BIE E40229	Flame control box			
59	BIE E11125	Relay			
POS	P/N	DESCRIPTION			
60	BIE G06073	Support plate			

NOTE: Not shown

Fuse for Flame Control Box - BIE E10325

### Optional Thermostat (5 Pin)

HWP DIGTHIDF-5	Optional thermostat with 50' cord
HWP 7979K24	5 pin plug insert
HWP 7979K32	5 pin plug cover

## Optional Accessories

*Note: If your incoming gas supply pressure is greater than 1/2 psi you will need a regulator to reduce the incoming pressure before installation to heater.*



### **REGULATOR**

#ACC 40SV06

Handles up to 60 psi

For NG pressure  
1-5 lbs. Call Heat Wagon



### **GAS HOSE**

#ACC 7525 - 3/4" x 25'

CSA certified for NG  
and Propane

Female Swivel Fittings  
Included



### **PRESSURE GAUGE**

#HWP HV1169

W.C. 0-15"

1/4" MNPT



### **ACC-INSTKIT**

*Everything you need for installation of  
propane tank to heater.*

*(Includes 25' of 3/4" hose)*

*Duct and Thermostat Information  
See Page 4*