



342 N. Co. Rd. 400 East
Valparaiso, IN 46383
888-432-8924 • Fax 219-462-7985
www.heatwagon.com

Installation and Maintenance Manual

Please retain this manual for future reference.

VF400

Construction Heater

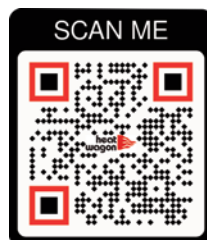

CAUTION: Do not use this heater in a space where gasoline or other liquids having flammable vapors are stored.

IMPORTANT INFORMATION! READ FIRST

The heater is designed for use as a construction heater under CSA-B140.8-1967 (General Requirements For Oil Burning Equipment) and UL-733 (Oil Fired Heaters and Direct Fired Heaters). Heater is not intended for use in pest remediation. The primary purpose of construction heaters is to provide temporary heating of buildings under construction, alteration, or repair and to provide emergency heat. Properly used, the heater provides safe, economical heating. Products of combustion are vented outside the area being heated.

Use of the heater must be in accordance with this Standard and in compliance with all governing state and local codes.

We cannot anticipate every use which may be made for our heaters. **CHECK WITH YOUR LOCAL FIRE SAFETY AUTHORITY IF YOU HAVE QUESTIONS ABOUT LOCAL REGULATIONS.**

Other standards govern the use of fuel gases and heat producing products in specific applications. Your local authority can advise you about these.

FOR YOUR SAFETY

DO NOT USE THIS HEATER IN A SPACE WHERE GASOLINE OR OTHER LIQUIDS HAVING FLAMMABLE VAPORS ARE STORED OR USED.

CONSTRUCTION HEATER GENERAL HAZARD WARNING:

Failure to comply with the precautions and instructions provided with this heater, can result in death, serious bodily injury and property loss or damage from hazards of fire, explosion, burn, asphyxiation, carbon monoxide poisoning, and/or electrical shock.

Only persons who can understand and follow the instructions should use or service this heater.

If you need assistance or heater information such as an instruction manual, labels, etc., contact your local Heat Wagon dealer or the manufacturer.

W A R N I N G

Fire, burn, inhalation, and explosion hazard. Keep solid combustibles, such as building materials, paper or cardboard, a safe distance away from the heater as recommended by the instructions. Never use the heater in spaces which do or may contain volatile or airborne combustibles, or products such as gasoline, solvents, paint thinner, dust particles or unknown chemicals.

Not for home or recreational vehicle use!

If you have read this entire manual and you still have questions, please call us at 219-464-8818

Installation and Maintenance Manual

Model VF400

Construction Heater

Table of Contents:

	Page
Specifications	4
Safety & Caution	5
Operating Instructions	5
Maintenance	7
Troubleshooting	8
Illustrated Parts Breakdown	12
Wiring Diagrams	15
Exhaust Flue Pipe Guidelines	18

WARRANTY

All new Heat Wagon and Sure Flame heaters and fans are guaranteed against defective materials and workmanship for one (1) year from Heat Wagon invoice date.

Warranty repairs may be made only by an authorized, trained and certified Heat Wagon dealer. Warranty repairs by other entities will not be considered. Warranty claims must include model number and serial number. Components are guaranteed to the extent of the components manufacturer's warranty.

LIMITATIONS

Warranty claims for service parts (wear parts) such as spark plugs, igniters, filters, nozzles, and flame rods will not be allowed. Diagnostic parts such as voltage meters and pressure gauges are not warrantable. Evidence of improper fuel usage, fuel pressures outside of manufacturer's specification, poor fuel quality, and improper electric power, misapplication or evidence of abuse may be cause for rejection of warranty claims.

Labor, travel time, mileage and shipping charges will not be allowed. Minor adjustments of heaters are dealers' responsibility. Defective parts must be tagged and held for possible return to the factory for 60 days from date of repair. The factory will provide a return goods authorization, (RGA) for defective parts to be returned. No warranty will be allowed for parts not purchased from Heat Wagon.



342 N. Co. Rd. 400 East • Valparaiso, IN 46383
219-464-8818 • 888-432-8924 • Fax 800-255-7985
www.heatwagon.com

SAFETY & CAUTION

- Instructions given in this manual and the applicable regulation of the local authorities must be followed.
- The unit may be operated only by those persons who have been instructed in its use.
- The unit is to be installed and operated in such a way as to ensure safety of employees and surroundings.
- Never cover the unit's air openings.
- Always secure an adequate fresh air supply to the unit.
- Never stand in front of the discharge end of the heater.
- Do not introduce foreign objects into the unit.
- Do not expose the unit to direct water jets.
- All electric cables outside the unit are to be protected against damage.
- Always disconnect the unit from power supply when maintenance or service is being performed.
- **IF NOT OPERATED WITHIN GUIDELINES OF THESE OPERATING INSTRUCTIONS MANUFACTURER WILL NOT BE HELD RESPONSIBLE AND WARRANTY WILL BECOME VOID.**

OPERATING INSTRUCTIONS

INSTALLATION

- When transporting, use both lifting eyes located on sides of heater.
- Place the unit on a level and non-combustible surface.
- Minimum clearances from combustible materials for indoor or outdoor installation on combustible flooring:
 - outlet, minimum 10 feet
 - sides, minimum 3 feet
 - top, minimum 3 feet
 - flue pipe exhaust, gas discharge minimum 2 feet
- Manufacturer recommends a free zone of 5 feet around the unit and a minimum distance of 10 feet at the unit's flue gas openings are to be maintained.
- If the unit is placed indoors, secure an adequate fresh air opening for the burner combustion air.
- The unit may not be installed and operated in premises where explosive or combustible fumes or dust are present. Check the regulation of local authorities, when necessary.
- Make sure that neither the air inlet nor the air outlet is obstructed.

FUEL SUPPLY

- This heater will burn kerosene (#1 or #2), diesel fuel (#1 or #2), and heating fuel (#1 or #2). It is highly recommended to use winterized fuel with ambient temperatures less than 20°F and to also install optional circulation or fuel tank heaters.
- The installation of this heater must comply with all applicable local codes.
- Check and clean fuel filter (if necessary) on a weekly schedule.

ELECTRICAL

- Electric cable extensions must be connected based on the unit capacity and cable length.
- Connect unit to a power supply with a suitable appliance receptacle (15 Amp).
- Confirm voltage at heater connection (105V min.) to ensure proper operation.

EXHAUST FLUE PIPE

- The unit is to be connected to a flue pipe with adequate draft, to ensure the proper start and operation of the unit. Refer to page 16.
- The flue pipe is to be made of non-combustible material and clearances from combustible materials must be a minimum 8 inches (temperature of flue gases is approximately 410° F).
- The flue pipe and its installation must comply with the regulations and instructions given by the local authorities.

START UP

- Only people who are trained in the operation and supervision of this heater should operate and maintain the unit.
- Check the unit to make sure that there are no visible defects on the control and safety devices and that the unit has been installed correctly.
 1. Check that the control switch on the control box is in position "0" (STOP).
 2. Pre-select desired room temperature on the room thermostat. The temperature must be set higher than the ambient temperature.
 3. Turn the control switch in control box to position "1" (HEATING).
 4. When the ambient temperature level is low, the burner switches on automatically. The fan does not switch on until the set temperature (104°F) of the heat-exchanger has been reached (will take approximately 1-5 minutes).
- After starting, the unit runs fully automatically with the pre-selected room temperature thermostat and it is controlled by its own control devices and safety limit controls.
- The room thermostat (TSTAT) and burner sensor control the running sequences of the burner and the fan sensor controls the fan function.
- Overheat limit reset (STB) controls and shuts off the heater (burner) in the case of overheating.
- The unit can also be used for ventilation purposes only, if needed.
 1. Turn the control switch on the control box to position "2" (VENTILATION).
 2. The unit is now in the continuous ventilating mode.
 3. Heating is not possible in this mode.

DUCTING (Warm Air)

- Clearness from combustible materials have to be a minimum of 4 inches.
- Use steel ducting or fabric ducting capable of withstanding a minimum temperature of 300°F.
- Maximum length of duct: 50' (straight).
- Duct diameter: 12".
- Make sure that the duct is safely and properly fastened to the outlet.
- Avoid sharp bends and corners to ensure maximum air flow and avoid back pressure/heat accumulation in heater.
- FAILURE TO COMPLY WITH THESE RECOMMENDATIONS COULD RESULT IN SHUTDOWN OF THE HEATER.

SHUT DOWN

- Turn control switch to position "0" (STOP).

Important!

The air supply fan continues running to cool down the combustion chamber/heat exchanger and then stops later. The fan can restart for several times before finally switching off!

WARNING!

UNIT MAY BE UNPLUGGED IN EMERGENCY SITUATIONS ONLY. OTHERWISE, DO NOT STOP THE UNIT BY UNPLUGGING IT. UNIT NEEDS TO COOL DOWN USING ITS OWN FAN. FAILURE TO COMPLY WITH PROPER SHUT-DOWN PROCEDURES CAN CAUSE DAMAGE TO THE COMBUSTION CHAMBER, HEAT EXCHANGER, SAFETY FEATURES AND ALSO VOID WARRANTY.

MAINTENANCE

Prior to starting any maintenance work, wait until unit cools down fully and fan shuts off before unplugging unit and beginning any maintenance work.
(Shut Down Procedures page 6)

To ensure the proper function of the unit, it must be serviced on regular basis. Maintenance can be performed, (excluding the control devices and safety limit controls), by an authorized trained & certified Heat Wagon dealer. The control devices and safety limit controls do not need routine maintenance. If these items fail they must be replaced.

- Do not use any aggressive cleaning agents (which are harmful or environmentally unfriendly), when cleaning the unit.
- Do not use water jet when cleaning the unit.
- Pressurized air may be used for maintenance. Be careful not to damage the fan blower wheel with too much pressure.
- - Check whether the unit is free from mechanical damage. Replace faulty parts as necessary.
- Check fan blower wheel at regular intervals and clean it when needed.
- Check functionality of control and safety devices regularly.
- Have the flue gas values of the burner checked regularly by authorized agents.
- Be sure to store the unit in a dust free and dry place when it is not used for a long period of time. Cover the exhaust flue to prevent entry of foreign objects.

SERVICE

- The complete unit, including heat exchanger, combustion chamber and burner should be cleaned from dust and dirt after every heating period, at a minimum of once per year.

-Removal of combustion chamber/heat exchanger:

For proper cleaning of the unit, manufacturer recommends removal of the complete combustion chamber with heat exchanger. Clean combustion chamber and heat exchanger tube with a brush. Vacuum all loose ash and soot. Close all cleaning flanges carefully to avoid damage to gasket material.

-Disassembling of burner:

1. Disassemble four tightening bolts on the combustion chamber flange and remove burner's mounting flange. Take care not to damage the flange seal.
2. Pull out the burner. Take care not to damage the burner head and power cable. Clean blower wheel, ignitor electrodes, and photocell. Replace fuel nozzle and fuel filter.

Refer to separate burner manual for adjustment of burner.

VF400 TROUBLESHOOTING

Symptom

Possible Causes

- 1. Turn the heater to position #1 and nothing happens.
 - Power supply cord
 - Burner reset button on the burner flame safeguard control box is tripped
 - Overheat limit switch is tripped
 - Burner sensor
- Heater control unit (HCU)

Possible Solutions

- Test for 120 volts between L1 and L2 on the main terminal block.
- Reset the button on the flame safeguard control.
- Reset the switch, which is on the side of the heater near the warm air outlet.
- On the heater control unit (HCU) disconnect the wires from terminals X10 and X11. Using an ohm meter, check the resistance between the two wires using the 1K ohms chart on page 16.
- On the main terminal block, check for 120 volts between terminals 8 and N when the 3-position switch is in the HEAT position.

- 2. The heater runs for a little while, but shuts down. It won't come on again until the limit switch is reset.

- Burner nozzle is improperly sized
- Incorrect burner fuel pump pressure
- Restricted airflow
- Overheat limit switch

- Nozzle is 3 GPH x 80° A.
- Use a high pressure gauge (160 PSI) with a 1/8" NPT inlet. Install gauge in the pressure tap port located on the top of the fuel pump. Run the unit and adjust the manifold pressure by turning the pressure adjusting screw (on the right hand side of the fuel pump) in or out until the gauge reads 110 PSI.
- Check for dirt or ice buildup on the air inlet or blower wheel. If using duct on the air outlet, insure the back pressure does not exceed a static pressure of .5" W.C.
- Adhere to the proper shut down procedures. Power must remain at the unit until it cools down fully. Blower will shut down on its own when cool. Test overheat limit switch for continuity between the two male terminals at room temperature. Replace if overheat limit switch fails test.

VF400 TROUBLESHOOTING

Symptom

3. I get the burner motor to come on, but the heater won't ignite.

Possible Causes

- Fuel pressure or volume
- Air inlet damper adjustment
- Ignition electrodes
- Electronic igniter
- Solenoid valve

Possible Solutions

- Use a high pressure gauge (160 PSI) with 1/8" NPT inlet. Install gauge in the gauge port located on top of the fuel pump. Run the heater. Adjust the pressure by turning the pressure adjusting screw (located on the right hand side of the fuel pump) counter clockwise until the gauge reads 110 PSI.
- Rough setting at 6.75 open. Minor adjustments from the rough settings can be made to achieve a smooth sounding burner with no soot from the flue pipe.
- Clean with fine sandpaper. Make sure it is free from buildup or cracks.
- Disconnect fuel solenoid valves and turn on the burner. Pull the igniter (using insulated pliers) away from the electrodes slowly. A rainbow colored arc should travel between the igniter and electrode bus bars at a distance of 3/8 of an inch for a duration of 4-5 seconds.
- If there is power at the flame safeguard control and no power out to the solenoid valves, replace the flame safeguard control. Check for continuity between the wires on the solenoid valve coil.

4. The heater has a loud rumbling sound.

Possible Causes

- Dirt on burner blower wheel
- Flue pipe setup or flue pipe restrictions
- Fuel pump pressure
- Fuel nozzle size
- Restricted heat exchanger

- Rough setting at 6.75 open on scale. Minor adjustments from the rough settings can be made to achieve a smooth sounding burner with no soot from the flue pipe.
- Clean the burner blower wheel with a small brush.
- Refer to the flue pipe chart in this manual. Check flue for restriction. See page 18
- Use a high pressure gauge (0-160 PSI) with 1/8" NPT inlet. Install gauge in the gauge port located on top of the fuel pump. Run the heater. Adjust the pressure by turning the pressure adjusting screw (located on the right hand side of the fuel pump) counter clockwise until the gauge reads 110 PSI.
- Nozzle is 3 GPH x 80° A.
- Refer to the cleaning instructions in this manual.

VF400 TROUBLESHOOTING**Symptom****Possible Causes**

5. The heater blows black smoke out of the vent stack.

- Air damper setting
- Dirt on burner blower wheel
- Flue pipe setup or flue pipe restrictions
- Fuel pump pressure
- Restricted fuel filter
- Incorrect fuel nozzle size
- Restricted heat exchanger

Possible Solutions

- Rough setting at 6.75 open on scale. Minor adjustments from the rough settings can be made to achieve a smooth sounding burner with no soot from the flue pipe.
- Clean the burner blower wheel with a small brush.
- Refer to the flue pipe chart in this manual. Check flue for restriction. See page 18
- Use a high pressure gauge (0-160 PSI) with 1/8" NPT inlet. Install gauge in the gauge port located on top of the fuel pump. Run the heater. Adjust the pressure by turning the pressure adjusting screw (located on the right hand side of the fuel pump) counter clockwise until the gauge reads 110 PSI.
- Clean or replace fuel filter.
- Nozzle is 3 GPH x 80° A.
- Refer to the cleaning instructions in this manual.

6. The burner seems to cycle on and off more than what it should.

- Fuel pump pressure
- Restricted fuel filter
- Dirt on main air blower or improper setup of outlet air duct
- Burner sensor
- Heater Control Unit (HCU)

- Use a high pressure gauge (0-160 PSI) with 1/8" NPT inlet. Install gauge in the gauge port located on top of the fuel pump. Run the heater. Adjust the pressure by turning the pressure adjusting screw (located on the right hand side of the fuel pump) counter clockwise until the gauge reads 110 PSI.
- Clean or replace fuel filter.
- Check for dirt or ice buildup on the air inlet or blower wheel. If using duct on the air outlet, insure the back pressure does not exceed a static pressure of .5" WC.
- On the heater control unit (HCU) disconnect the wires from terminals X10 and X11. Using an ohm meter, check the resistance between the two wires using the 1K ohms chart on page 16.
- If all of the above check good, replace the HCU.

VF400 TROUBLESHOOTING

Symptom

7. The burner starts, but the main fan never comes on.

Possible Causes

- Fan sensor
- Heater Control Unit (HCU)

• Blower motor relay

• Blower motor

Possible Solutions

- On the heater control unit (HCU) disconnect the wires from terminals X12 and X13. Using an ohm meter, check the resistance between the two wires using the 1K ohms chart on page 16.
- Turn the 3-position main switch to the fan position. If the blower runs, check the fan sensor. If it is good, replace the HCU.
- Turn the 3-position main switch to the fan position. If the relay pulls in, check for voltage between the L1 and L2 terminals. Then check the voltage between terminals T1 and T2. The voltage should be the same. If it is much lower, replace the relay.
- Turn the 3-position main switch to the fan position. Check for voltage between terminals T1 and T2 on the motor relay. If the voltage is good, replace the motor.

8. The burner continues to run, but the fan cycles on and off.

• Fuel pump pressure

• Fan sensor

• Heater Control Unit (HCU)

- Use a high pressure gauge (0-160 PSI) with 1/8" NPT inlet. Install gauge in the pressure tap port located on top of the fuel pump. Run the heater. Adjust the pressure by turning the pressure adjusting screw (located on the right hand side of the fuel pump) until the gauge reads 110 PSI.
- On the heater control unit (HCU), disconnect the wires from terminals X12 and X13. Using an ohm meter, check the resistance between the two wires using the 1K ohms chart on page 16.
- Turn the 3-position main switch to the fan position. If the blower runs, check the fan sensor. If it is good, replace the HCU.

WAYNE BURNER PARTS BREAKDOWN

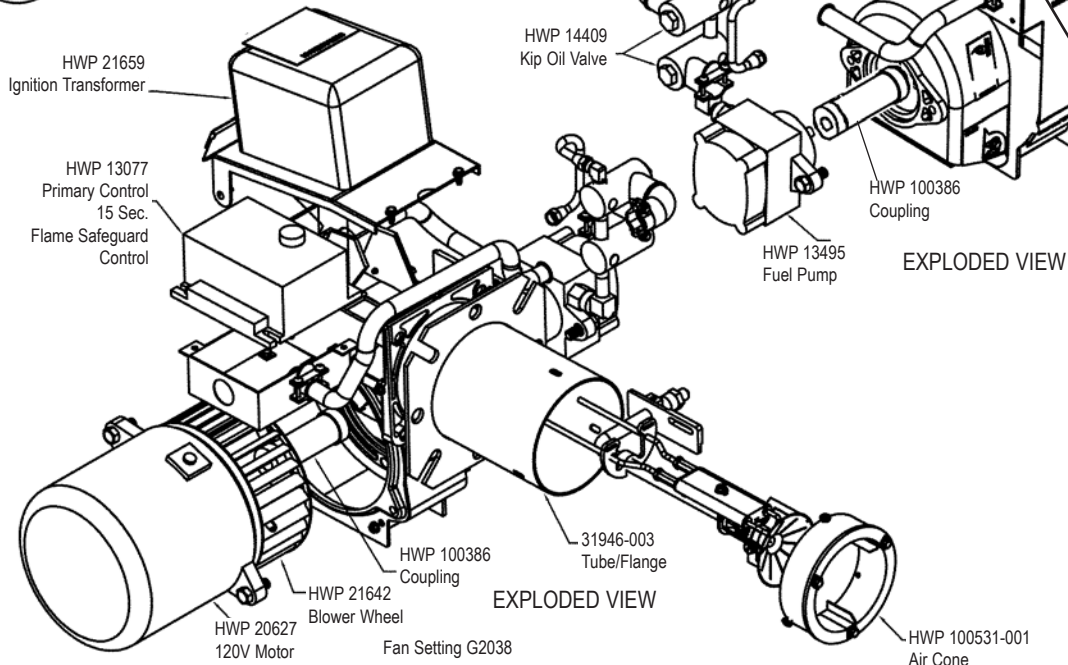
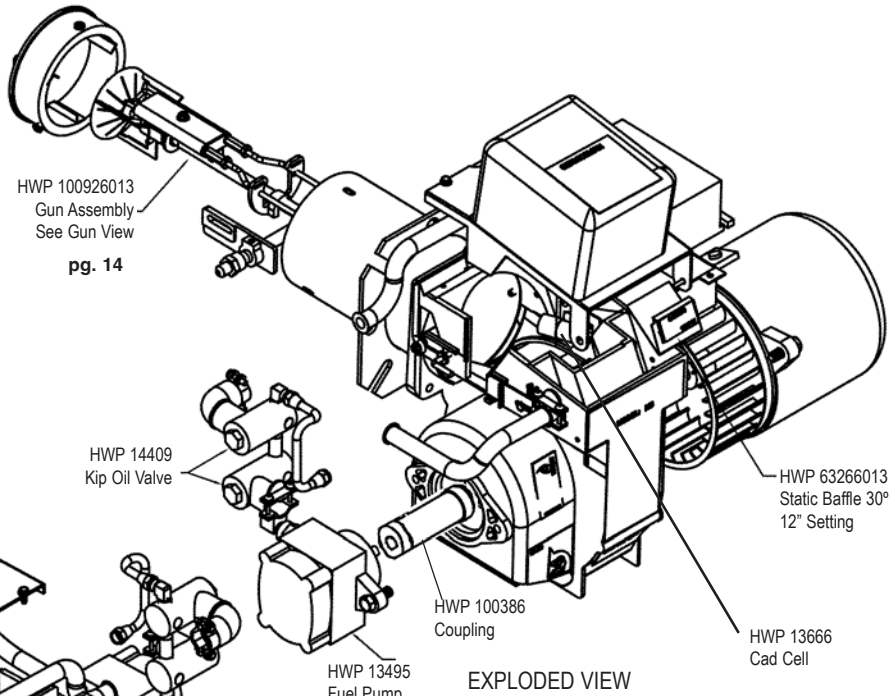
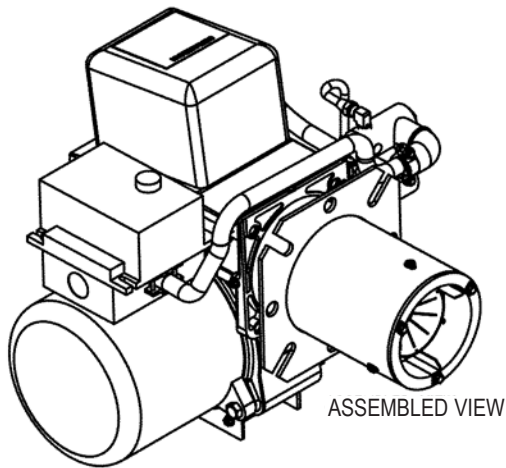

ELECTRODE SETTING

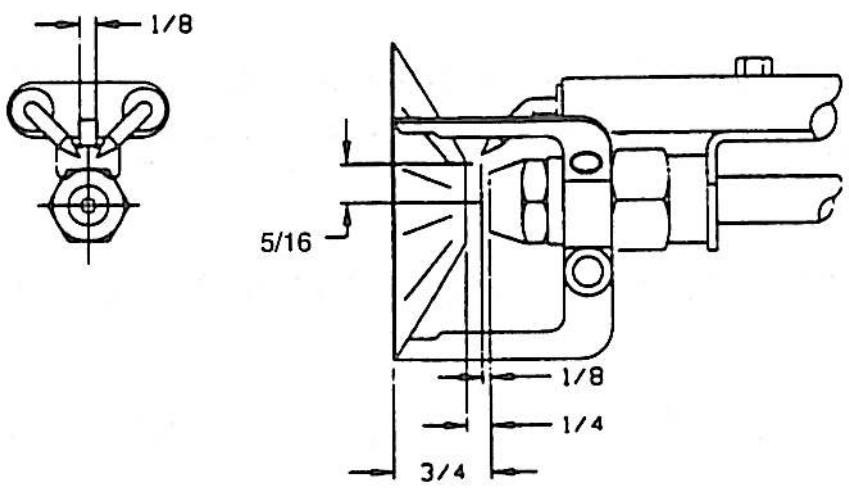
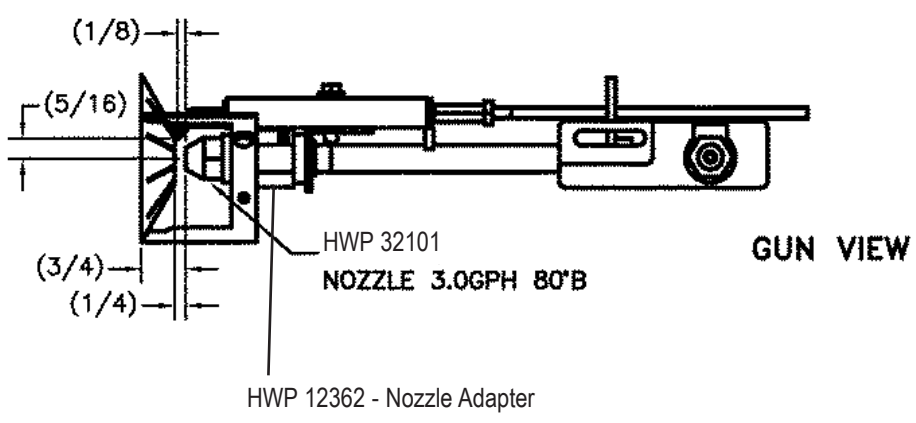
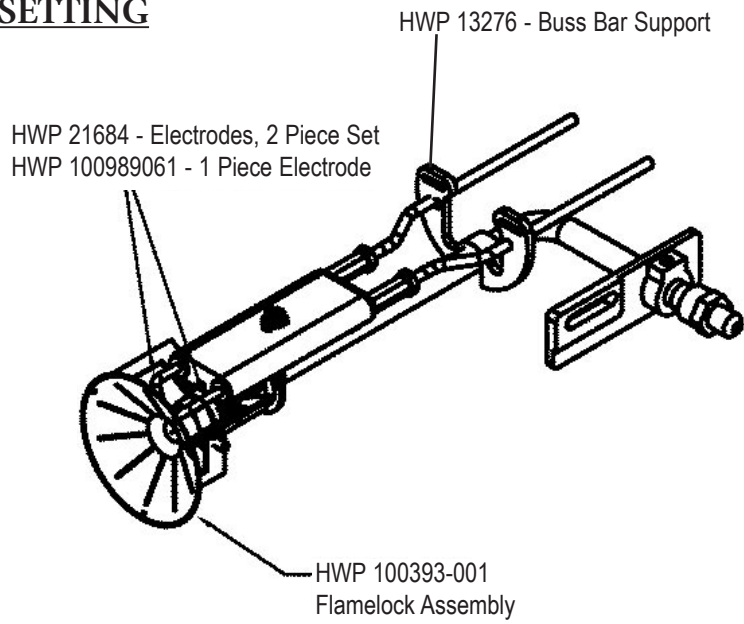

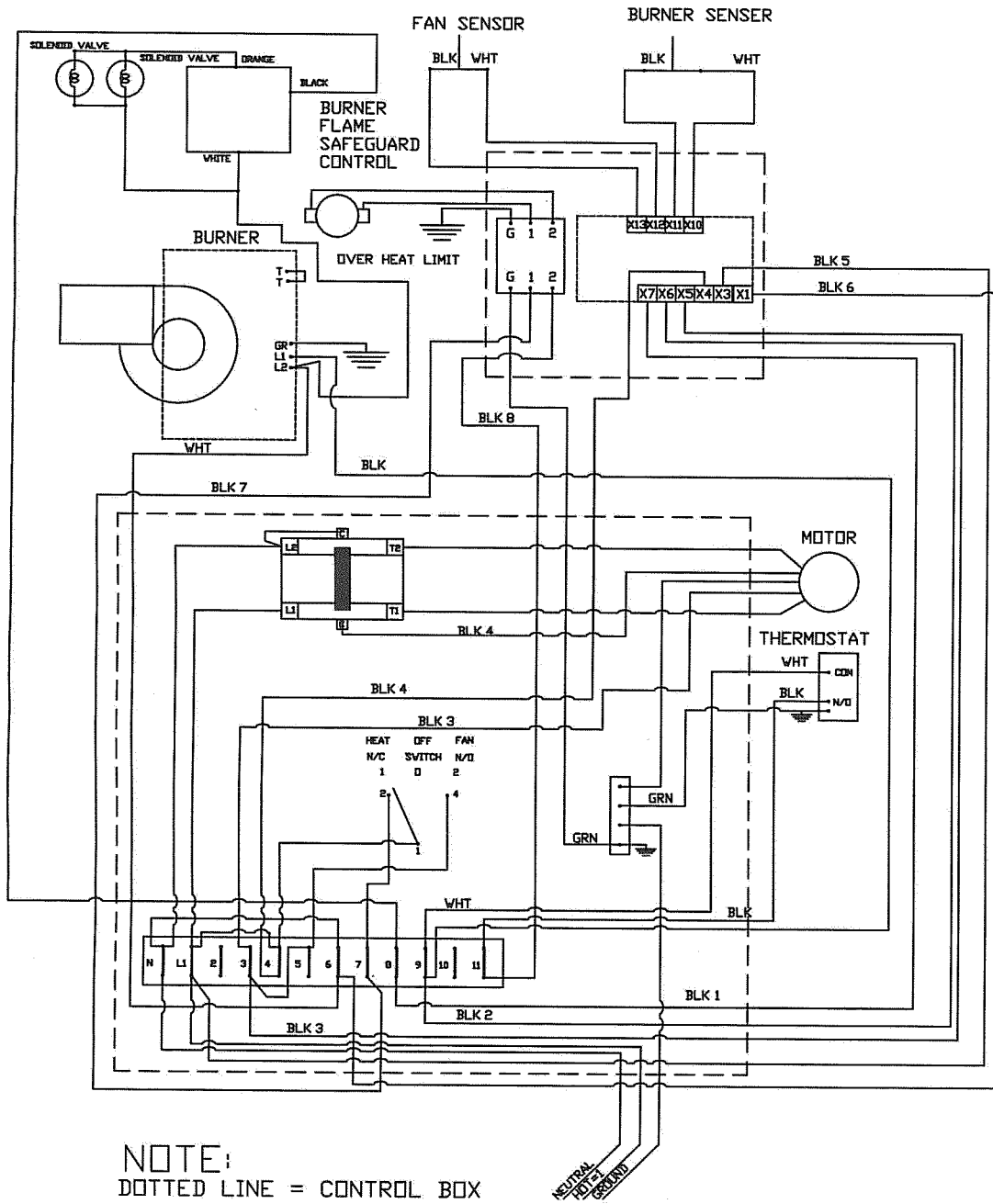

120 Volt 1 PH

ITEM	PART#	DESCRIPTION
E1	HWP 41000	MAIN CONTROL BOX
E2	HWP 40850	THERMOSTAT BOX
E3	HWP 40900	FAN CONNECTION BOX
S1	HWP 120021	MAIN SWITCH
S2	HWP 20579	HEATER CONTROL UNIT, MODEL HW120
B1	HWP 20581	FAN SENSOR (for S4)
	HWP 20583	
B2	HWP 20582	BURNER SENSOR (for S5)
S3	HWP 21800	OVERHEAT LIMIT SWITCH (BIMETALLIC)
	HWP 21400	OVERHEAT LIMIT (CAPILLARY)
X1	HWP 36701	TERMINAL BLOCK (E1)
X2	HWP 36100	GROUNDING BLOCK (E1)
	HWP HC1020	POWER CABLE & PLUG
X4	HWP 36701	TERMINAL BLOCK (E2)
X5	HWP 36701	TERMINAL BLOCK (E3)

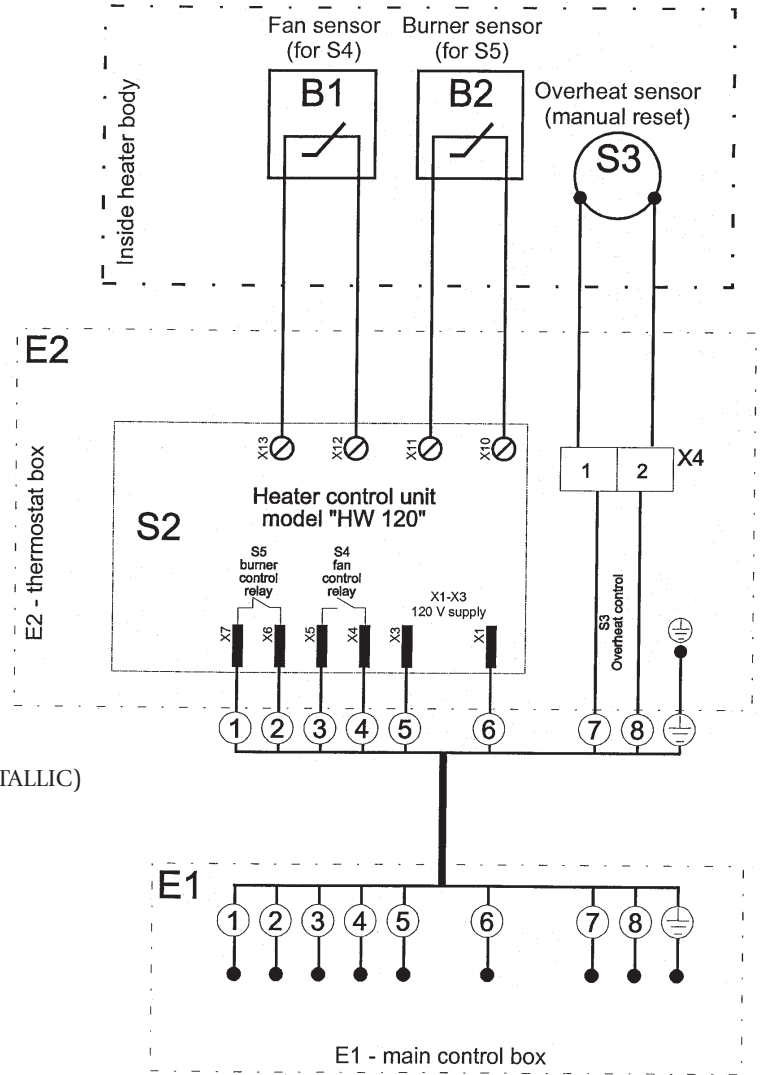

SENSOR RESISTANCE CHART

Degrees Farenheight	Degrees Celcius	Resistance (1K Ohm Scale)*	Degrees Farenheight	Degrees Celcius	Resistance (1K Ohm Scale)*
-40	-40	330.6	185	85	1.07
-31	-35	239	194	90	0.9156
-22	-30	174.7	203	95	0.7862
-13	-25	129	212	100	0.6777
-4	-20	96.21	221	105	0.5863
5	-15	72.42	230	110	0.5089
14	-10	55.01	239	115	0.4433
23	-5	42.14	248	120	0.3873
32	0	32.55	257	125	0.3395
41	5	25.34	266	130	0.2985
50	10	19.87	275	135	0.2633
59	15	15.7	284	140	0.2328
68	20	12.49	293	145	0.2065
77	25	10	302	150	0.1836
86	30	8.059	311	155	0.1636
95	35	6.534	320	160	0.1455
100	40	5.329	329	165	0.1303
113	45	4.371	338	170	0.1169
122	50	3.604	347	175	0.1052
131	55	2.988	356	180	0.09484
140	60	2.489	365	185	0.08569
149	65	2.084	374	190	0.07757
158	70	1.753	383	195	0.07037
167	75	1.481	392	200	0.06396
176	80	1.256			

* Correct Ohm reading when sensors are at the above listed temperatures

120 Volt 1 PH

BLOWER MOTOR SCHEMATIC

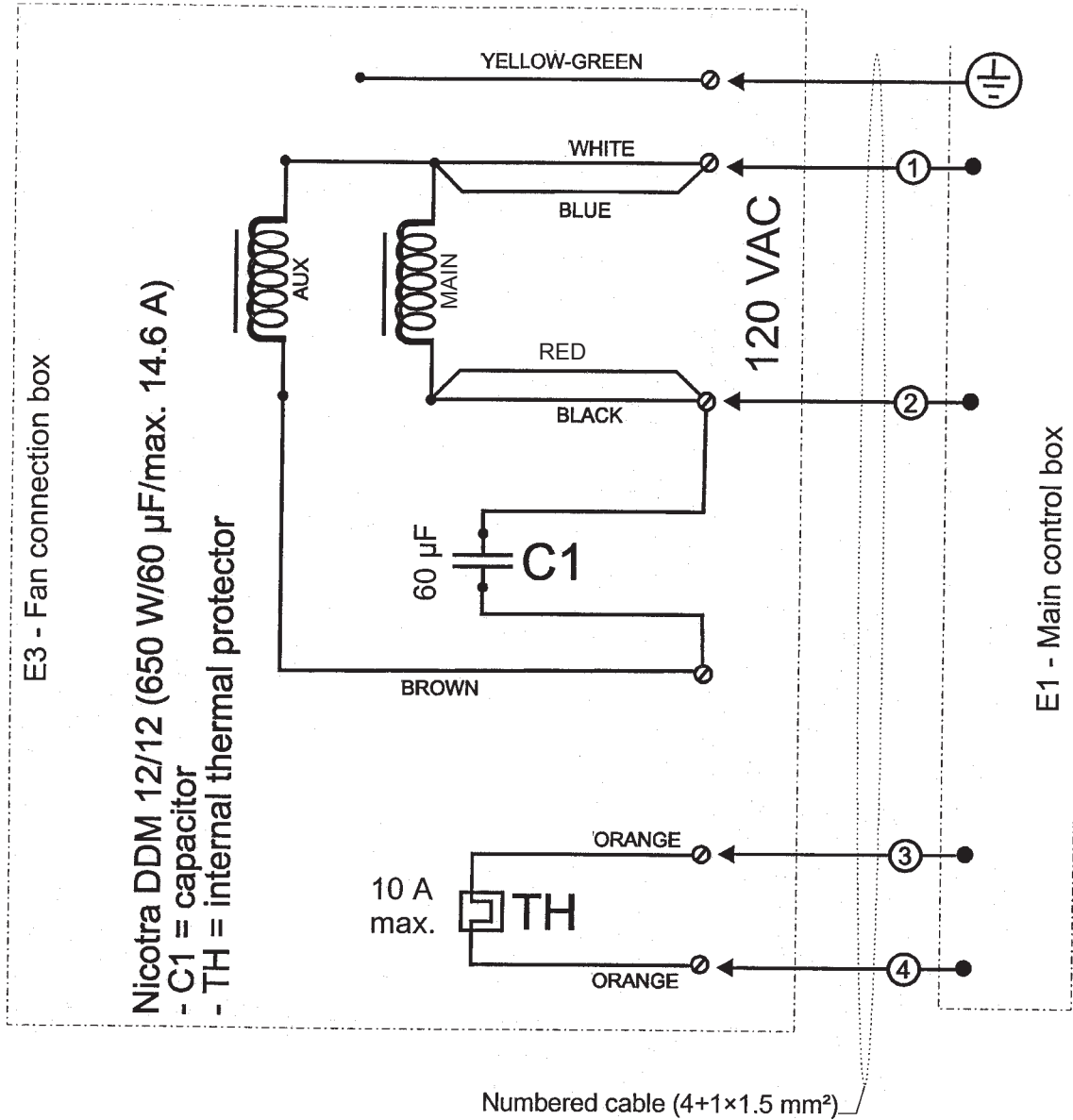

EXHAUST FLUE PIPE GUIDELINES

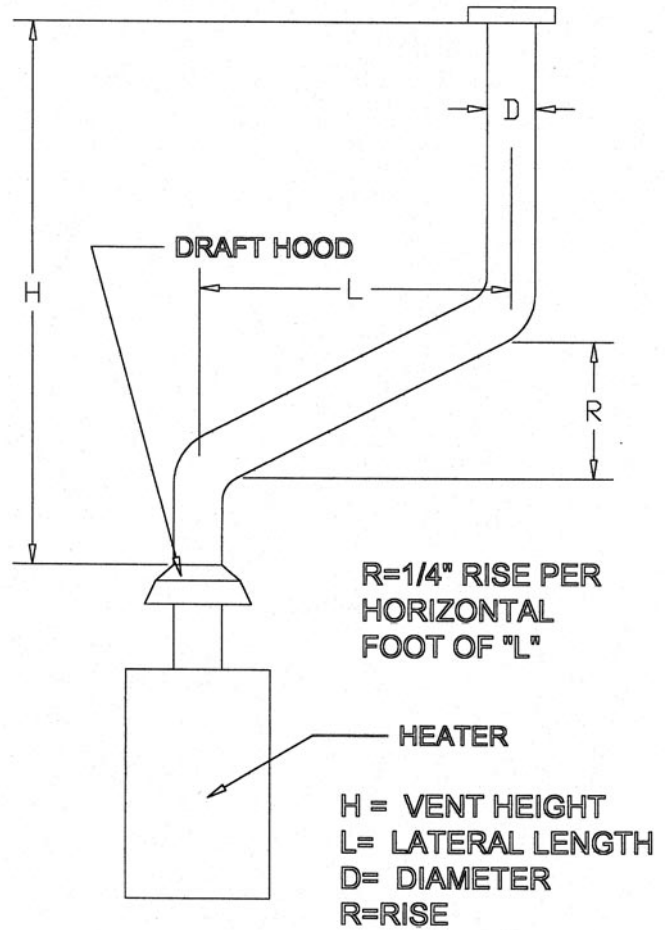
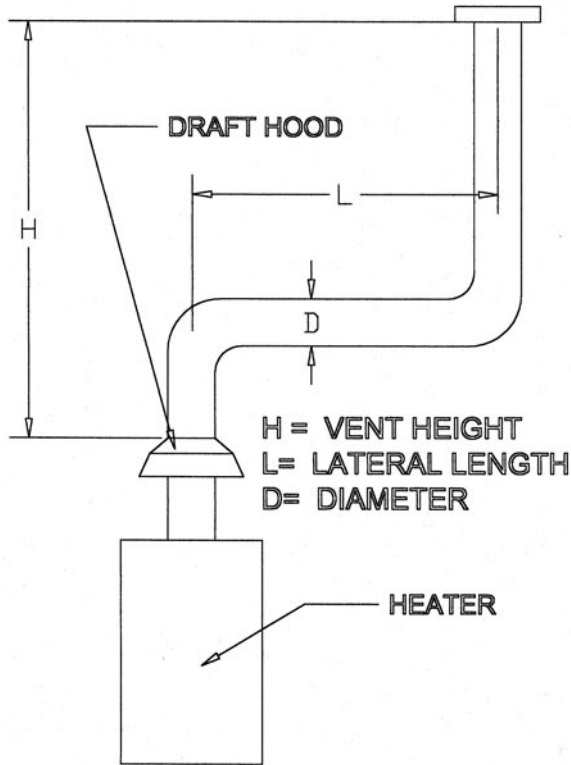

CAPACITY OF TYPE B DOUBLE-WALL VENTS SERVING A SINGLE DRAFT HOOD-HEATER x 1000 BTU'S

FOR INDOOR APPLICATIONS

		VENT DIAMETER (D) INCHES			
		8	10	12	14
TOTAL VENT HEIGHT (H) FEET	LATERAL LENGTH (L) FEET				
6	0	370	570	850	1170
	2	285	455	650	890
	6	273	435	630	870
	12	255	406	610	840
8	0	415	660	970	1320
	2	322	515	745	1020
	8	303	490	720	1000
	16	281	458	685	950
10	0	450	720	1060	1450
	2	355	560	850	1130
	10	330	525	795	1080
	20	300	486	735	1030
15	0	525	840	1240	1720
	2	414	675	985	1350
	15	373	610	905	1250
	30	328	553	845	1180
20	0	575	930	1350	1900
	2	470	755	1100	1520
	10	443	710	1045	1460
	20	410	665	990	1390
30	0	380	626	945	1270
	2	650	1060	1550	2170
	2	535	865	1310	1800
	20	473	784	1185	1650
	40	415	705	1075	1520

Heat Wagon Offers You More Options



Oil Fired Fuel Tank

VF400 Tank (FT400)

- 75 gallon tank
- Single wall tank
- Forklift capability from all four sides
- Minimum 25 hour run time
- 160 lbs. (empty) - 750 lbs. (full)



Circulation Fuel Preheater

(210076)

- Ensures quick smooth "cold weather" start-up
- Independently tested & certified to -20°F
- Standard on VF1000
- Optional on VF400



Immersion Heater for Fuel Tank (FT400HT)

- 120V (1000 watts)
- Keeps fuel at optimal flow rate and prevents fuel "gelling"
- Must be used in conjunction with the FT400 fuel tank

We Stock A Complete Line Of Parts & Accessories



DUCTING

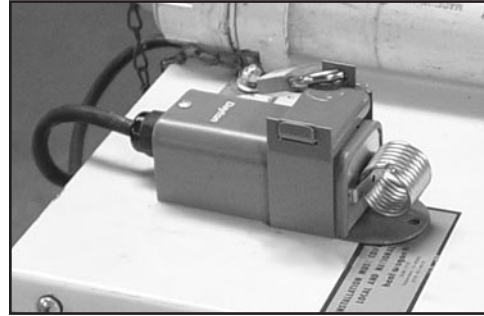

THERMOSTAT
LOCK BOXES



HOSES



REGULATORS



342 N. Co. Rd. 400 East
Valparaiso, IN 46383
219-464-8818 • Fax 219-462-7985
www.heatwagon.com