



342 N. Co. Rd. 400 East
Valparaiso, IN 46383
888-432-8924 • Fax 219-462-7985
www.heatwagon.com

Installation and Maintenance Manual

Please retain this manual for future reference.

VG750 VG1100

Construction Heater



CAUTION: Do not use this heater in a space where gasoline or other liquids having flammable vapors are stored.

IMPORTANT INFORMATION! READ FIRST

The heater is designed for use as a construction heater under ANSI Z83.7a-2000. Heater is not intended for use in pest remediation. The primary purpose of construction heaters is to provide temporary heating of buildings under construction, alteration, or repair and to provide emergency heat. Properly used, the heater provides safe, economical heating. Products of combustion are vented outside the area being heated.

The heater IS NOT designed as an Unvented Gas Fired Room Heater under ANSI-Z21.11.2 and SHOULD NOT be used in the home.

ANSI A119.2(NFPA 501C)-1987 Recreational Vehicle Standard prohibits the installation or storage of LP-gas containers even temporarily inside any recreational vehicle. The standard also prohibits the use of Unvented Heaters in such vehicles.

NFPA-58 1989 STANDARD FOR THE STORAGE AND HANDLING OF LIQUEFIED PETROLEUM GASES

Use of the heater must be in accordance with this Standard and in compliance with all governing state and local codes. Storage and handling of propane gas and propane cylinders must be in accordance with NFPA 58 and all local governing codes.

We cannot anticipate every use which may be made for our heaters. CHECK WITH YOUR LOCAL FIRE SAFETY AUTHORITY IF YOU HAVE QUESTIONS ABOUT LOCAL REGULATIONS.

Other standards govern the use of fuel gases and heat producing products in specific applications. Your local authority can advise you about these.

CAUTION

DO NOT USE THIS HEATER IN A SPACE WHERE GASOLINE OR OTHER LIQUIDS HAVING FLAMMABLE VAPORS ARE STORED OR USED.

CONSTRUCTION HEATER GENERAL HAZARD WARNING:

Failure to comply with the precautions and instructions provided with this heater, can result in death, serious bodily injury and property loss or damage from hazards of fire, explosion, burn, asphyxiation, carbon monoxide poisoning, and/or electrical shock.

Only persons who can understand and follow the instructions should use or service this heater.

If you need assistance or heater information such as an instruction manual, labels, etc., contact your local Heat Wagon dealer or the manufacturer.

W A R N I N G

Fire, burn, inhalation, and explosion hazard. Keep solid combustibles, such as building materials, paper or cardboard, a safe distance away from the heater as recommended by the instructions. Never use the heater in spaces which do or may contain volatile or air-borne combustibles, or products such as gasoline, solvents, paint thinner, dust particles or unknown chemicals.

Not for home or recreational vehicle use!

If you have read this entire manual and you still have questions,
please call us at 219-464-8818

Installation and Maintenance Manual

Model VG750-VG1100

Construction Heater

Table of Contents:

	Page
Control Board/Panel/Manifold	5-7
Installation	9-13
Operating Instructions	13-14
Maintenance	14-15
Troubleshooting	16
Wiring Diagram	17
Illustrated Parts Breakdown	18-24
Specifications	25-26
Riello Burner	27-52
Exhaust Flue Pipe Guidelines	53

WARRANTY

This heater is guaranteed against defective materials and workmanship for one (1) year from Heat Wagon invoice date.

Warranty repairs may be made only by an authorized, trained and certified Heat Wagon dealer. Warranty repairs by other entities will not be considered. Warranty claims must include model number and serial number. Components are guaranteed to the extent of the component manufacturer's warranty.

LIMITATIONS

Warranty claims for service parts (wear parts) such as spark plugs, igniters, and flame rods will not be allowed. Diagnostic parts such as voltage meters and pressure gauges are not warrantable. Evidence of improper fuel usage, fuel pressures outside of manufacturer's specification, poor fuel quality, improper electric power, misapplication and/or evidence of abuse may be cause for rejection of warranty claims.

Labor, travel time, mileage and shipping charges will not be allowed. Minor adjustments to heaters are the responsibility of the dealer. Defective parts must be tagged and held for possible return to the factory for 60 days from date of repair. The factory will provide a return goods authorization, (RGA) for defective parts to be returned. No warranty will be allowed for parts not purchased from Heat Wagon.



342 N. Co. Rd. 400 East • Valparaiso, IN 46383
219-464-8818 • 888-432-8924 • Fax 800-255-7985
www.heatwagon.com

WARNING

BEFORE USING THE HEATER, READ AND UNDERSTAND ALL INSTRUCTIONS AND FOLLOW THEM CAREFULLY.

THE MANUFACTURER IS NOT RESPONSIBLE FOR DAMAGES TO GOODS OR PERSONS DUE TO IMPROPER USE OF THE UNITS.

GENERAL HAZARD WARNING

FAILURE TO COMPLY WITH THE PRECAUTIONS AND INSTRUCTIONS PROVIDED WITH THIS HEATER, CAN RESULT IN DEATH, SERIOUS INJURY AND PROPERTY LOSS OR DAMAGE FROM HAZARDS OF FIRE, EXPLOSION, BURN, ASPHYXIATION, CARBON MONOXIDE POISONING, AND / OR ELECTRICAL SHOCK.

ONLY PERSONS WHO CAN UNDERSTAND AND FOLLOW THE INSTRUCTIONS SHOULD USE OR SERVICE THIS HEATER.

IF YOU NEED ASSISTANCE OR HEATER INFORMATION SUCH AS AN INSTRUCTION MANUAL, LABEL, ETC., CONTACT THE MANUFACTURER.

WARNING: FIRE, BURN, INHALATION AND EXPLOSION HAZARD

KEEP SOLID COMBUSTIBLES, SUCH AS BUILDING MATERIALS, PAPER OR CARDBOARD, AT SAFE DISTANCE AWAY FROM THE HEATER AS RECOMMENDED BY THE INSTRUCTIONS.

NEVER USE THE HEATER IN SPACES WHICH DO OR MAY CONTAIN VOLATILE OR AIRBORNE COMBUSTIBLES, OR PRODUCTS SUCH AS GASOLINE, SOLVENTS, PAINT THINNER, DUST PARTICLES OR UNKNOWN CHEMICALS.

WARNING

NOT FOR HOME OR RECREATIONAL VEHICLE USE. INSTALLATION OF THIS HEATER IN A HOME OR RECREATIONAL VEHICLE MAY RESULT IN A FIRE OR EXPLOSION, PROPERTY DAMAGE, PERSONAL INJURY OR LOSS OF FIRE.

WARNING

IMPROPER INSTALLATION, ADJUSTMENT, ALTERATION, SERVICE OR MAINTENANCE CAN CAUSE INJURY OR DEATH.

READ THE INSTALLATION, OPERATING AND MAINTENANCE INSTRUCTIONS THOROUGHLY BEFORE INSTALLING OR SERVICING THIS EQUIPMENT.

FOR YOUR SAFETY

IF YOU SMELL GAS:

1. OPEN WINDOWS
2. DO NOT TOUCH ELECTRICAL SWITCHES
3. EXTINGUISH ANY OPEN FLAME
4. IMMEDIATELY CALL YOUR GAS SUPPLIER

FOR YOUR SAFETY

DO NOT STORE OR USE GASOLINE OR OTHER FLAMMABLE VAPOURS AND LIQUIDS IN THE VICINITY OF THIS OR ANY OTHER APPLIANCE.

WARNING

The heater is designed and approved for use as a construction heater in accordance with Standard ANSI Z83,7 CGA 2.14.

CHECK WITH YOUR LOCAL FIRE SAFETY AUTHORITY IF YOU HAVE QUESTIONS ABOUT APPLICATIONS.

Other standards govern the use of fuel gases and heat producing products in specific applications. Your local authority can advise you about these.

WARNING

This heater can be washed, provided that:

- A. The heater is disconnected from the electrical supply.
- B. All access panels are securely closed.
- C. Water spray nozzle shall not discharge within 6 feet of the heater.
- D. The heater is not reconnected to electrical supply until thoroughly dried.

Improper cleaning of the heater can cause severe personal injury or property damage due to water and/or cleaning solutions:

- A. In electrical components, connections and wires causing electrical shocks or component failure.
- B. On gas control components causing corrosion which can result in gas leaks and fire or explosion from the leak. The hose assembly must be protected from the traffic, building materials and contact with hot surfaces both during use and while in storage.

WARNING

Proper gas supply must be provided to the inlet of the appliance.

Refer to rating plate for proper gas supply pressure.

Gas pressure in excess of maximum inlet pressure specified at the appliance inlet can cause fire or explosions, leading to serious injury, death, building damage or loss of livestock.

Likewise, gas pressure below the minimum inlet pressure specified at the appliance inlet may cause improper combustion, leading to asphyxiation, carbon monoxide poisoning and therefore serious injury or death to humans and livestock.

Position heater properly before use.

For either indoor or outdoor use adequate ventilation must be provided.

Minimum clearance from combustible materials and propane containers: 10 ft.

Do not operate heater with panels removed.

Not for use with ductwork.

To avoid injury from moving parts, disconnect all electrical power to equipment before opening doors or removing panels.

WARNING

RETAIN THIS INSTRUCTION FOR FUTURE REFERENCE..

CONTROL BOARD

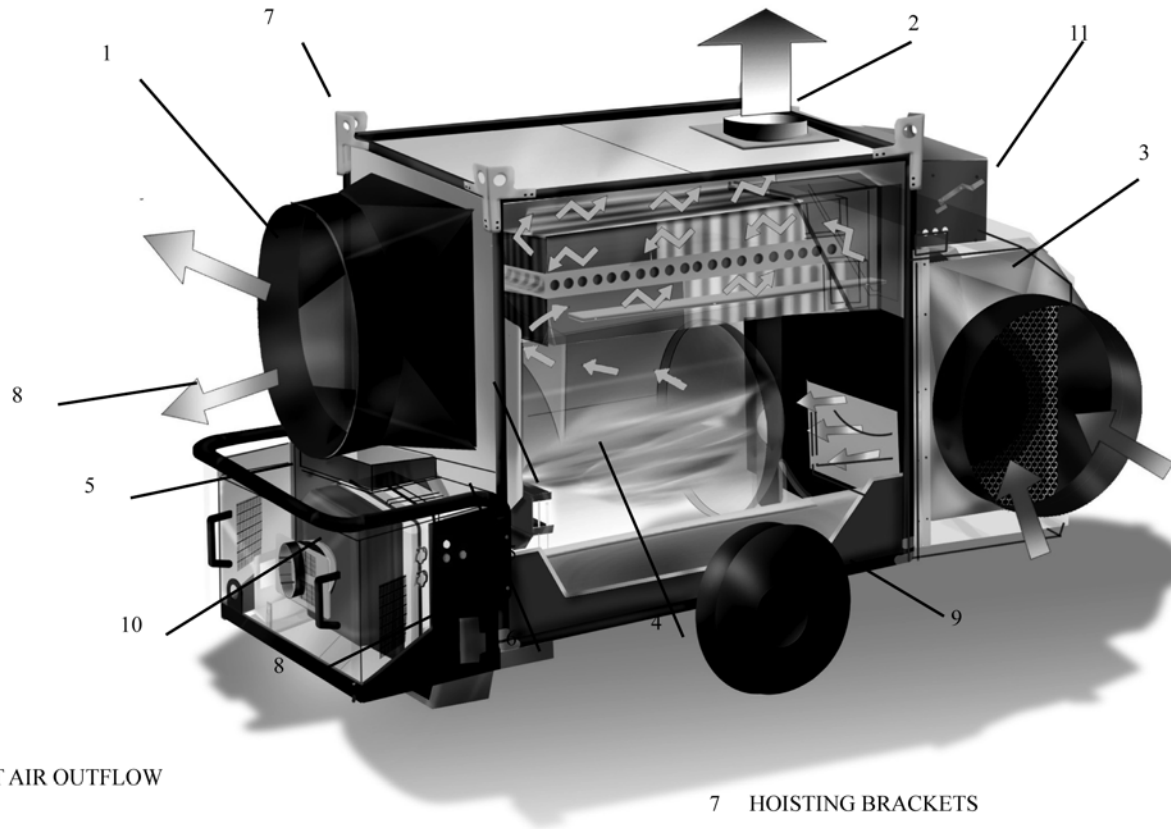

1 HOT AIR OUTFLOW

2 CHIMNEY

3 COOLING FAN

4 COMBUSTION CHAMBER

5 BURNER

6 THERMOSTATS L2 BOX

7 HOISTING BRACKETS

8 SUPPORT/HANDLE

9 WHEEL

10 BURNER BOX

11 ELECTRICAL PANEL BOX

CONTROL PANEL

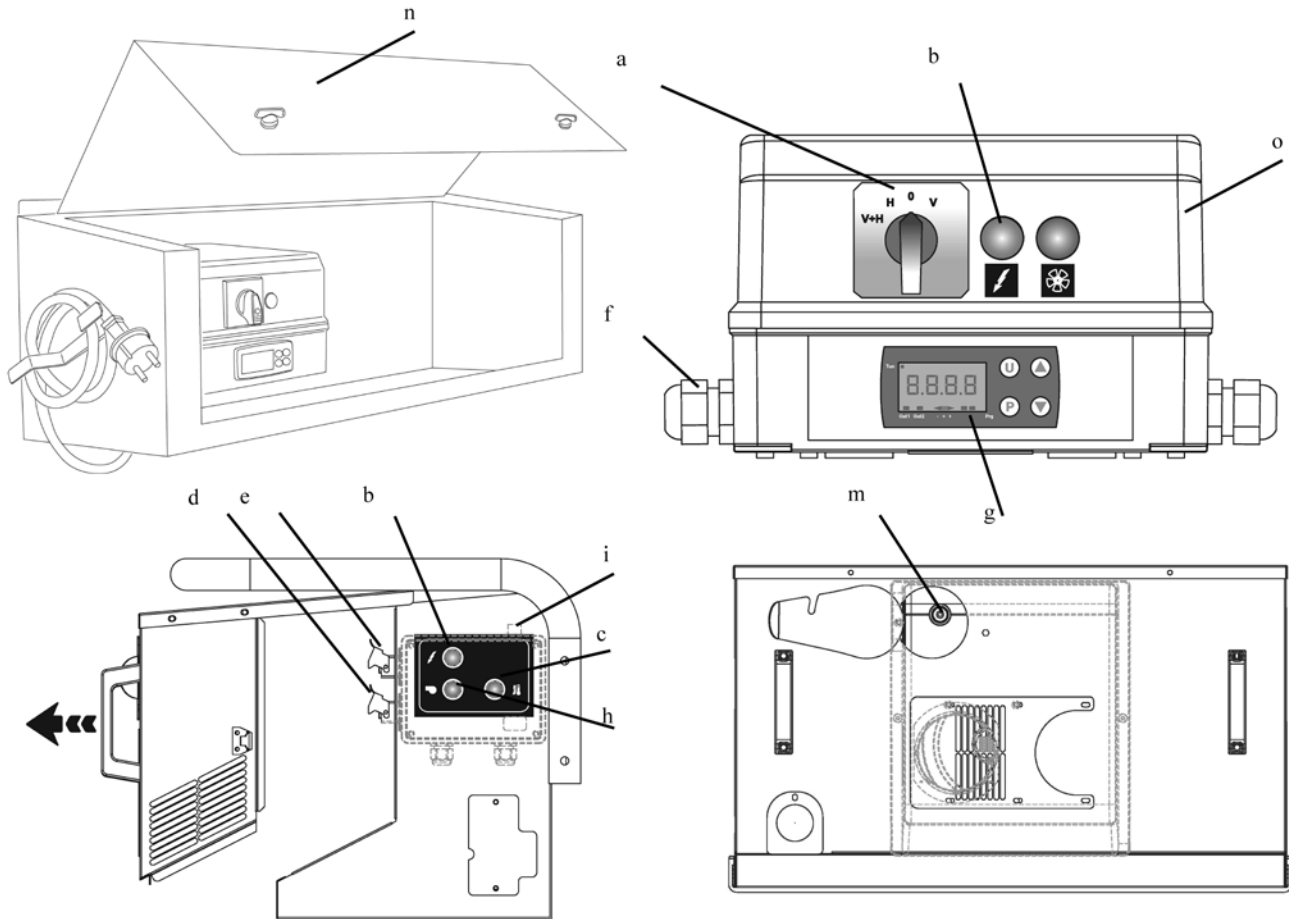

a HEATING-VENTILATION SWITCH

b VOLTAGE LAMP

c OVERHEAT THERMOSTATS CONTROL LAMP, L2

d ROOM THERMOSTAT PLUG

e INTAKE FOR PRE-HEAT FILTER

f CABLE CLAMP FOR POWER CABLE

g TEMPERATURE CONTROLLER

h BURNER LIGHT

i SAFETY THERMOSTAT RESET BUTTON, L2

m BURNER RESET BUTTON / LAMP

n ELECTRICAL PANEL BOX PANEL

o ELECTRICAL PANEL

MANIFOLD ASSEMBLY

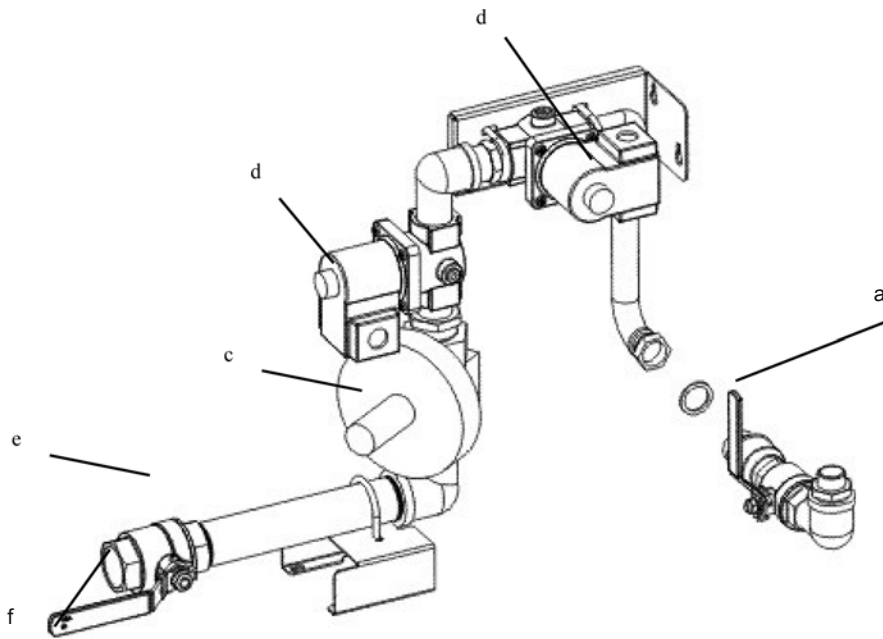

- a GAS SELECTOR VALVE - VG750 - T30359-2
VG1100 - T30360-1
- b MANIFOLD PRESSURE PORT - VG750 - T30125
(MANIFOLD) VG1100 - T30124
- c MANIFOLD PRESSURE REGULATOR - VG750 - T30125
VG1100 - T30124
- d MAIN GAS VALVE - VG750 - T30123
VG1100 - T30123
- e INLET PRESSURE PORT - VG750 - T30123
VG1100 - T30123
- f SHUT OFF / FIRING VALVE - T30361

**VAPOR PROPANE QUICK
REFERENCE HOSE
CHART**

Hose Length in Feet	BTU 1 Million	
	1/2PSI	10PSI
10	1-1/4	3/4
25	1-1/4	3/4
35	1-1/2	3/4
50	1-1/2	3/4
75	2	3/4
100	2	3/4
125	2	3/4
150	2	3/4
175	2	3/4
200	2	3/4
225	2	3/4

**NATURAL GAS QUICK
REFERENCE HOSE
CHART**

Hose Length in Feet	BTU 1 Million			
	<1PSI	1PSI	2PSI	5PSI
10	1-1/2	1-1/4	3/4	3/4
25	2	1-1/4	3/4	3/4
35	2	1-1/4	3/4	3/4
50	2	1-1/4	1	3/4
75	2	1-1/4	1-1/4	3/4
100	2	1-1/4	1-1/4	3/4
125	2-1/2	1-1/2	1-1/4	1
150	2-1/2	1-1/2	1-1/4	1
175	2-1/2	1-1/2	1-1/4	1
200	2-1/2	1-1/2	1-1/4	1-1/4
225	2-1/2	1-1/2	1-1/4	1-1/4

VAPORIZATION RATES IN BTUH @ 0 DEG. F							
TANK SIZE	NUMBER OF TANKS MANIFOLDED	PERCENTAGE OF TANK FILLED					
		10%	20%	30%	40%	50%	60%
250							
	1	126,900	169,200	197,400	225,600	253,800	282,000
	2	279,180	372,240	434,280	496,320	558,360	620,400
500	3	486,027	648,036	756,042	864,048	972,054	1,080,060
	1	198,135	264,180	308,212	352,240	396,270	440,300
	2	435,897	581,196	687,066	774,928	871,794	968,660
1000	3	758,857	1,011,809	1,180,451	1,349,079	1,517,714	1,686,349
	1	354,240	472,320	551,040	629,760	708,480	787,200
	2	779,328	1,039,104	1,212,288	1,385,472	1,558,656	1,731,840
	3	1,356,739	1,808,985	2,110,483	2,411,980	2,713,478	3,014,976

NOTE: USE FOLLOWING MULTIPLIERS FOR OTHER AIR TEMPERATURES

- For -10° F multiply x 0.50
- For + 10°F multiply x 1.5
- For +20°F multiply x 2.0
- For +40°F multiply x 3.0
- For +50°F multiply x 3.5
- For +60°F multiply x 4.0

IMPORTANT

Before using the space heater, carefully read all of the instructions and follow them scrupulously. The manufacturer cannot be held responsible for damage to persons and/or property caused by improper use of the equipment.

This instruction manual is an integral part of the equipment and must therefore be stored carefully and passed on with the unit in the event of a change of ownership.

1. DESCRIPTION

Space heaters described in this manual, are designed for use in medium to large-sized rooms and buildings where a fixed or mobile heating system is required.

The air required for combustion is sucked directly by the burner (6) installed on the heater, and can be supplied:

- from the outside by using the flexible connection tube (available as an accessory), which avoids consuming oxygen in the room to be heated, or
- from inside the room to be heated. In this case, the room must be well ventilated to guarantee sufficient exchange of air.

The flow of hot air is moved by the high-efficiency fan (4): air is heated by the thermal energy generated during combustion and heat

is transmitted to the fresh air through the metal walls of the sealed combustion chamber and the heat exchanger. After the combustion products are cooled, they are conveyed to a discharge duct and eliminated through a chimney or flue large enough to guarantee their removal.

The space heaters can work with burners having ON-OFF work modes and fuelled by natural gas or propane or diesel #2 max.

Warning



Only burners approved by the manufacturer and listed in the “TECHNICAL SPECIFICATION TABLE” can be used.

The heater's certification and warranty will lapse if the burner is replaced with a non-original model, even if it has similar specifications.

All of the space heaters are fit with an electronic device that controls the flame and with:

- safety devices (safety thermostat with manual reset, flame control, air pressure switch) that trip in case of serious malfunctions and cause a safety stop. In this case the heater stops, button (d) lights with a steady red light (Stop Light) and the heater can resume operation only after the cause of the stop has been identified and eliminated;
- control devices (temperature controller to control temperature of air outflow, complete with hour counter, fan thermostat, burner thermostat, voltage control, and gas pressure switch) that trip in case of minor operating faults or supply faults, causing temporary stop of the space heater. In this case, the heater will restart automatically when the required condition is restored.

The section “TROUBLESHOOTING” describes all possible operating faults and their possible remedies.

2. CONDITIONS OF SUPPLY

The heater is delivered with parts to be assembled and set as described in chapter 4.

- Heater body
- Burner
- Air distribution connector
- Any required accessories (flue pipes, air distribution pipes, etc.)

Warning



Prior to installation, burner adjustment and ignition, the space heater should be assembled in full.

All assembly operations should only be performed by professionally qualified personnel only.

Warning



Upon completing assembly, the identification labels provided in the following packaging:

- space heater
- burner

should be applied both on the space heater's serial number label and on the declaration of assembly and installation on the penultimate page of this manual.

The following are also supplied:

- use and maintenance manuals for
 - space heater
 - burner
- manuals with drawings and spare part lists:
 - space heater
 - burner

Warning



All documents provided constitute an integral part of the unit.

The documents should therefore be looked after with care and supplied with the unit in the event of a change in ownership.

Parts are to be transported and moved using either a manual or automatic forklift truck with sufficient load capacity.

Warning



Never try to lift the heater manually. Doing so could cause serious physical injury.

3. GENERAL ADVICE

The space heater must be installed, adjusted, and used in conformity to national and local laws and regulations for its operation.

General guidelines:

- Follow the instructions in this booklet very carefully;
 - The heater is not installed in an area where there is a high risk of fire or explosions;
 - Minimum clearances from combustible material must be:
 - 1 m (3 feet) from side and rear (air inlet) of heater
 - 1 m(3 feet) on top of heater
 - 3 m (10 feet) on air outlet of heater.
 - Keep inflammable material at a safe distance from the heater (minimum 3 metres);
 - Check that there is no overheating of walls, ceilings or floors made of inflammable materials,
 - All precautions have been taken to prevent fires;
 - The room being heated must be sufficiently ventilated so that the heater has enough air to function properly;
 - The heater must be near a chimney or chimney flue and an electrical panel conforming to declared specifications;
 - Check the heater before switching it on and at regular intervals during its use;
 - After use, make sure the disconnecting switch is off.
- When using any type of space heater it is obligatory:
- not to exceed the maximum heat output level of the furnace (“TECHNICAL SPECIFICATION TABLE”);
 - make sure that the air flow is not below the rated level; check that there are no obstacles or obstructions to the air suction and/or delivery ducts, such as sheets or covers on the equipment, walls or large objects near the heater.

Warning



This unit may not be used by persons (including children) with reduced physical, sensorial or mental capacities or with limited experience and familiarity unless they are under supervision or instructed on how to use the unit by the person responsible for its safety.

4. INSTALLATION INSTRUCTIONS

Warning



All of the operations described in this section must be performed by professionally qualified personnel only.

The installation shall be in accordance with National Fuel Gas Code ANSI Z223.1/NFPA 54 and with CAN1-B149.1 Installation code.

An approved manual gas valve shall be provided by the installer.

4.1. INSTALLATION ON FLOOR OR CEILING

The space heater may be installed:

- on the floor in a stable position

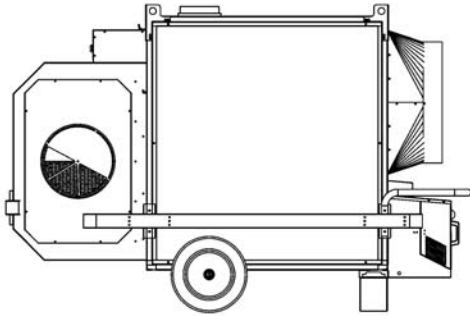

- or suspended by hooking it to the ceiling using cables and/or chains of an appropriate size and length secured to the four suspension points.

Warning



Make sure that the ropes and/or chains form an angle not more than 5° with vertical to the ceiling, that the ropes do not cross, and that a different rope is used for each hook.

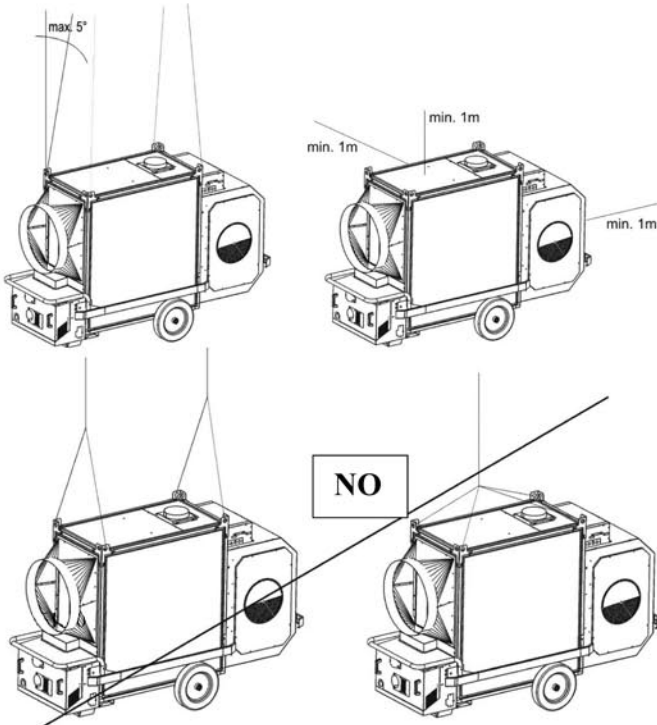

The minimum distance from surrounding walls and/or ceiling must always be at least 1 metre.

The centrifugal fan has a panel (B1) with a sliding shutter (C1) to emit fresh air for ventilation. The shutter should be set ONLY if connected to air suction ducts (see paragraph 4.4.2).

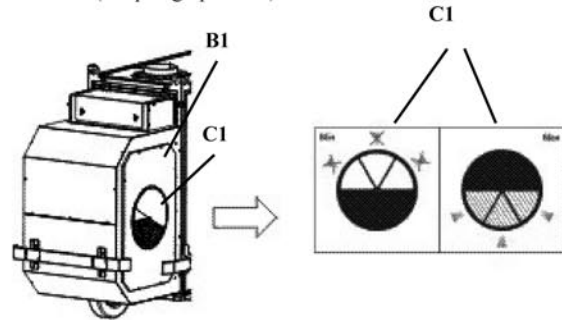

Warning



Accessory (A1) (see paragraph 4.3.2) for connecting the air suction duct and panel (B1) with pair flow adjustment shutter (C1) can be assembled on either the right or left side of the fan casing.

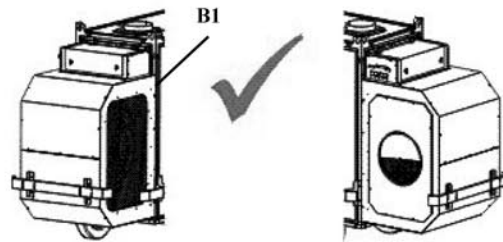
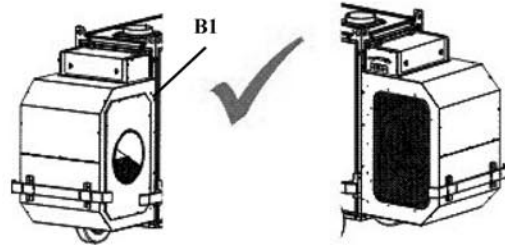

Warning



Accessory (A1) for connecting the air suction duct and panel (B1) with pair flow adjustment shutter (C) must NEVER be removed, even if air suction ducts are not connected: the absence of these panels may cause damage to the fan motor.

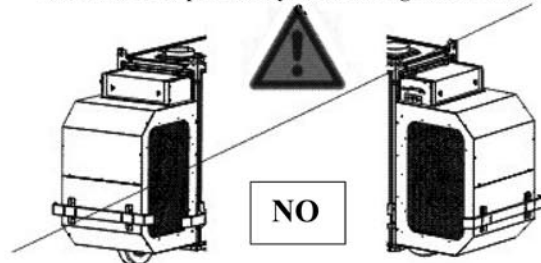

4.2. POWER CONNECTIONS

Warning



The 120V unit is fitted with a proper power cord. The 220V equipment is fitted with a grounded plug. Power cord must be sized in accordance with national rules.

Warning



The power line of the generator must feature an ground and a residual current circuit breaker. The supply cable must be connected to a switchboard with sectioning switch.

Warning



When installed, the appliance must be electrically grounded in accordance with local codes, or in the absence of local codes, with the National Electrical Code, ANSI/NFPA 70, and/or the CSA C22.1, Canadian Electrical Code, if an external electrical source is utilized.

The electrical power cable must be connected in conformity to the polarity specified on the main terminal board of the electrical panel: phase (L) and neutral (N).

Warning



If polarities L and N are incorrect, the space heater may stop a few seconds after it is switched on for the first time.

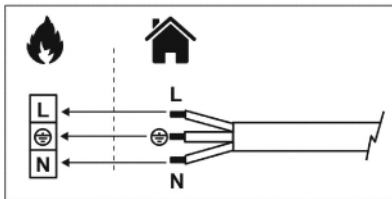

Before switching on the heater and, therefore, before plugging it into the electrical power supply, check that the power supply specifications are the same as those stated on the identification plate.

Any room thermostat or other accessories (such as a timer) are connected to the system by connecting the electrical cable to the thermostat plug (c):

- Take the plug (c) out of the electrical panel, open the plug and remove the jumper between terminals 2 and 3.
- Connect the thermostat electrical cable to terminals 2 and 3 of the thermostat plug (c).
- Close the plug again and plug it back into the panel.

Warning



Never attempt to switch the heater on or off by connecting the room thermostat (or other control devices) to the electrical power line.

The installation and connection of all the other accessories are described in the specific instructions included with each accessory, together with operating instructions.

The electrical diagram shown in this manual refers to the electrical connection only.

4.3. CONNECTION TO HOT AIR DUCTS

4.3.1. AIR DELIVERY DUCTS

The space heater is set to operate with direct distribution of air.

Nevertheless, it can be connected to appropriately sized air distribution channels, if required, with maximum diameter and length as shown in the "TECHNICAL SPECIFICATION TABLE."

Warning



Before starting the heater, check that the direction of rotation of the fan matches the direction shown on the fan itself.

distribution channels can be connected by using the various accessories supplied, placing the connector head-on to one or more outlets chosen as needed.

4.3.2. AIR SUCTION DUCTS

The heater can be connected to suction ducts to distribute air from the room to be heated. These ducts must comply with the maximum diameter and length specified in the "TECHNICAL SPECIFICATION TABLE" and must be connected with accessory (A1) (provided), to be assembled on the centrifugal fan casing.



The centrifugal fan has a panel (B1) with a sliding shutter (C1) to emit fresh air for ventilation. The shutter can be set from a minimum value (position D1) to a maximum value (position E1).

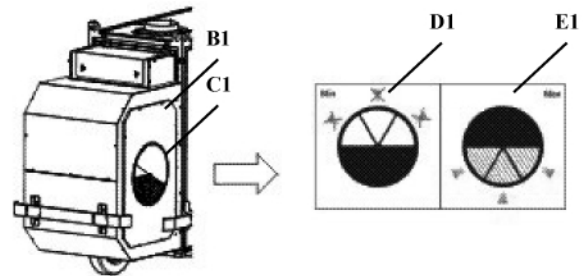

Warning



Accessory (A1) for connecting the air suction duct and panel (B1) with pair flow adjustment shutter (C1) can be assembled on either the right or left side of the fan casing.

4.5. CONNECTION TO FUEL SUPPLY

Warning



The heater must be installed, set up, and used in compliance with all applicable regulations.



Before installing, check the gas supply conditions required for the type of gas chosen.

Warning



Check all threaded connections on the gas line. When commissioning, check for any gas leaks or seepages using soap and water

The gas supply pipe must be properly sized, conform to the installed thermal power, and guarantee the necessary conditions for gas supply.

Warning



The gas supply pressure must be guaranteed during heater operation and not with the heater off.

The space heater has a gas ramp with: gas filter, pressure regulator, safety electrovalve, work electrovalve, pressure stabilizer, pressure valve. It is good practice for the installer to set up the supply line as follows:

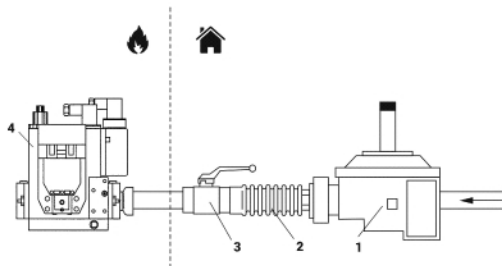

- | | |
|--|------------------------|
| 1: filter-pressure regulator or filter | 2: antivibration joint |
| 3: stopcock | 4: gas ramp |

Parts (1), (2) and (3) are available as accessories and are not supplied with the heater.

When the line has been connected:

- Bleed the gas supply pipe;
 - Check that the gas pipe is sealed.
 - Open the gas stopcock and check the seal of all connections to the heater.
- In case of connection of heater to natural gas, the installation shall conform with local codes or, in the absence of local codes, with the National Fuel Gas Code ANSI Z223.1/NFPA 54 and the Natural Gas and Propane Installation Code, CSAB149.1.

In case of connection to a propane supply cylinder:

- (a) the installation must conform with local codes or, in the absence of local codes, with the Standard for the Storage and Handling of Liquefied Petroleum Gases, ANSI/NFPA 58 and the Natural Gas and Propane Installation Code, CSA B149.1.
- (b) to determine size and capacity of the cylinder(s) and for any specific

requirements consult your LP gas supplier. In any case propane tank should not be lower than 100 lb (90 liters)

- (c) the cylinder supply system shall be arranged to provide for vapour withdrawal from the operating cylinder;
- (d) the gas shall be turned off at the propane supply cylinder when the heater is not in use;
- (e) when the heater is to be stored indoors, the connection between the propane supply cylinder and the heater must be disconnected and the cylinders removed from the heater and stored in accordance with Standard for the Storage and Handling of Liquefied Petroleum Gases, ANSI/NFPA 58 and CSA B149.1, Natural Gas and Propane Installation Code.

The appliance and its individual shut-off valve must be disconnected from the gas supply piping system during any pressure testing of that system at test pressures in excess of 1/2 psi (3.5 kPa).

The appliance must be isolated from the gas supply piping system by closing its individual manual shut-off valve during any pressure testing of the gas supply piping system at test pressures equal or less than 1/2 psi (3.5 kPa).

A minimum 1/8" NPT plugged tapping, accessible for test gauge connection, must be installed immediately upstream of the gas supply connection to the appliance.

4.6. CONNECTING BURNER TO "SNORKEL" DEVICE AND SETTING COMBUSTION AIR

The burner air intake (3) can be connected outside the room to be heated in order to suck in clean air and avoid depleting the oxygen in the room.

The connection pipe must be rigid to prevent shrinking due to air intake depression. It must have a minimum diameter of 100 mm and maximum length of 6 metres.

Warning



If the hose is too long, remove the excess without leaving loops and/or curves which may hinder air suction.

To connect the air pipe to the burner intake:

- remove burner box cover (a)
- remove burner box closure panel (b)
- insert air pipe (c) into the hole on closure panel (b) and fix it to Snorkel intake (d) on the burner
- reassemble burner box cover (a) by sliding it along air pipe (c), making sure that air pipe (c) does not detach from Snorkel intake (d)
- fix panel (a) on the burner intake by turning it upside down so that air pipe (c) is locked.

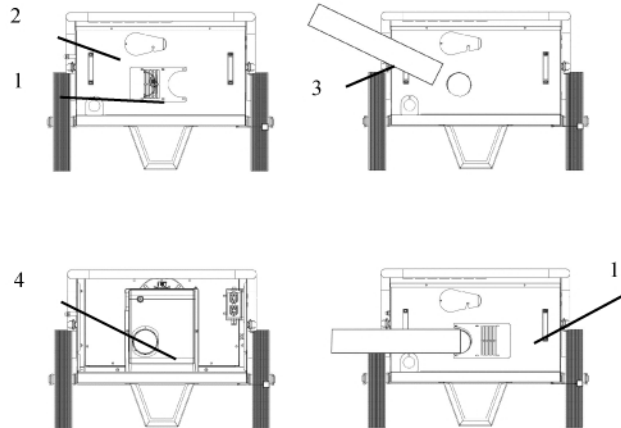

The end part of the suction hose should be connected to a wall accessory with safety grille to prevent small animals and/or debris from entering the hose.

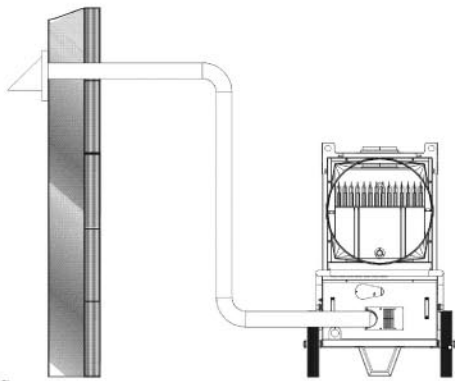

Warning



Burner air should be adjusted in accordance with the indications listed in the "TECHNICAL SPECIFICATION TABLE".

4.7. CONNECTION TO EXHAUST DUCT

Exhaust ducts must be in steel and conform to local/national rules. Efficient combustion and trouble-free working of the burner depend on efficient flue draft.

The unit must be connected to the chimney flue in compliance with current legal regulations and in line with the following guidelines:

- The path of the flue pipe smoke should be as short as possible and should slant upwards (minimum height 1 m);
- There should be no sharp curves in the pipes, and the diameter of the pipes must never be reduced;
- there must always be a wind deflector to prevent the entrance of rain and to prevent smoke from being blocked by the wind;
- flue draft must at least equal the level in the Technical Specifications.
- When the heater is connected to a flue pipe, the flue pipe shall terminate in a vertical section at least two feet long and sufficient draft shall be created to assure safe and proper operation of the heater;
- every heater must have its own chimney;

The following diagrams show possible flue positions:

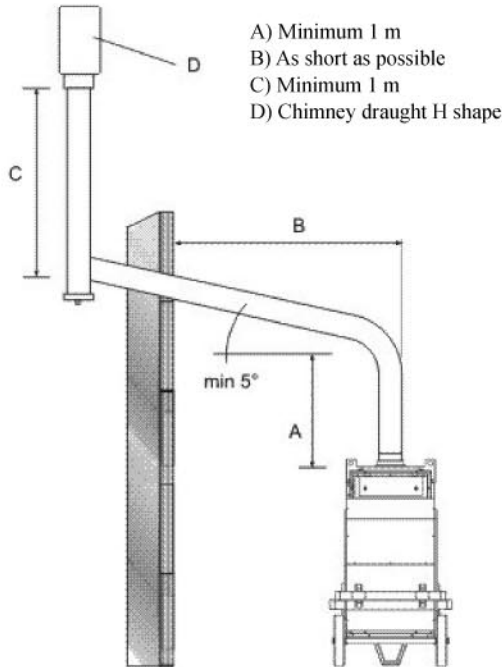

See page 47 for additional details

Warning



Coaxial flue pipes must not under any circumstances be used for flue gas exhaust and burner air suction on these units: functioning may be irreparably compromised.

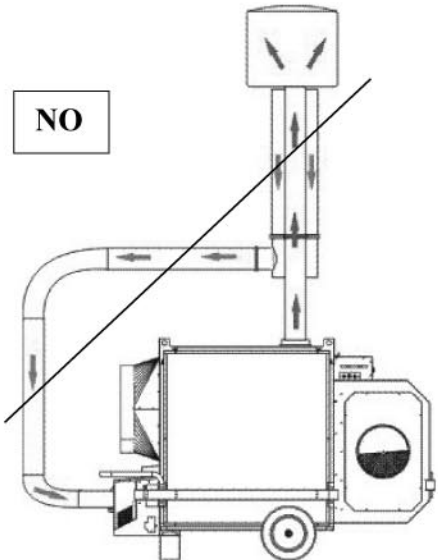

4.8. FIRST START-UP

The heater is supplied after a complete functional test and it's therefore prearranged for one of the gas (natural or L.P.G.) indicated in Tab. I: an adhesive label applied on the manual gas selector valve (Fig. 4) indicates the working gas (usually it's natural gas). Should it necessary to change the kind of gas (from natural gas to L.P.G or viceversa) follow the detailed instructions indicated in section "CHANGING TYPE OF GAS".

Only when the heater has been prearranged according to the proper working gas it will be possible to carry out the following operations:

- Leak away some gas from the feed pipe;
- Check that the pipe is gas proof;
- Open the gas stopcock and start the hot air generator;

For installation in the U.S.A. at elevation above 2,000 feet (610 m), the appliance shall be derated 4 per cent for each 1,000 feet (305 m) of elevation above sea level.

For installation in Canada at elevation above 2,000 feet to 4,500 feet above sea level, the heater is derated reducing the input for the appropriate fuel in accordance with the rating plate manifold pressure.

Warning



THE CONVERSION SHALL BE CARRIED OUT BY A MANUFACTURER'S AUTHORIZED REPRESENTATIVE, IN ACCORDANCE WITH THE REQUIREMENTS OF THE MANUFACTURER, PROVINCIAL OR TERRITORIAL AUTHORITIES HAVING JURISDICTION AND IN ACCORDANCE WITH THE REQUIREMENTS OF THE CAN/CGA-B149.1 OR CAN/CGAB149.2 INSTALLATION CODES.

A conversion label shall be applied adjacent to the Rating Label:

THIS APPLIANCE HAS BEEN CONVERTED FOR USE AT AN ALTITUDE OF _____ FEET (ABOVE 2000 FEET)

Orifice size: _____
 Manifold pressure: _____
 Input rate: _____
 Date of conversion: _____
 Type of fuel: _____
 Converted by: _____

For installation in Canada at elevation above 4,500 feet above sea level, consult Provincial or Territorial Authorities having jurisdiction.

You can continue and start up the heater only after it has been prepared it according to the instructions for the work category to be used.

4.9 CHANGING TYPE OF GAS

This operation may be carried out several times during the working life of the machine and not only at initial start-up. Therefore, first of all check the

adhesive label attached to the manual gas selector valve (a) in Fig. (2) to establish the original category of the gas and then consult Tab. I to identify the supply pressure, the working pressure, the use conditions of manual valve.

To change kind of gas it is necessary (Fig. 2):

- to remove the sticker on the manual gas selector valve stating the gas used at that time,
- to remove the screw under the sticker and turn the manual handle on the correct side according to the condition described in Tab.I and by following instruction:

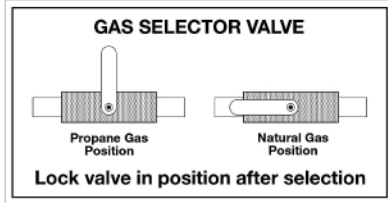

Fig. 4

- After having moved the handle into the opposite position, put again the fixing screw and a new sticker on it, stating the gas which has to be used (a number of different stickers are supplied with the machine)

Warning



Burner pressure shall not be adjusted: the heater is ready to run on the new gas

Should it necessary to check the burner pressure:

- connect a manometer to the pressure port located on the burner support ,
- carry out the pressure reading on the manometer and turn the pressure regulator (c) if necessary to obtain the correct burner pressure value indicated in Tab. I

4.10. REGULATING COMBUSTION AND ANALYSING COMBUSTION PRODUCTS

Warning



The first start-up should always be carried out by a specialised technician checking the correctness of the combustion parameters.

Warning



The burner settings are pre-set at the factory and may not comply with those required, therefore, the settings need to be checked and, where necessary, corrected.

The adjustment values (gas fuel pressure, burner gas pressure, combustion head position, air adjustment) for each of the burners approved for these units are indicated in the “TECHNICAL SPECIFICATION TABLE”.

The probe used to periodically check combustion and flue smoke temperatures is to be inserted as indicated:

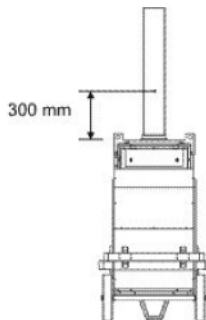

Combustion is clean and stable when combustion values are as follows:

	NATURAL GAS G20 - G25	LIQUID GAS G30 - G31
Index Bacharach	-	0 (white)
CO ₂	8,5 ÷ 9,5 %	11,5 ÷ 12,5 %
Oxygen (O ₂)	4,5 ÷ 6 %	4,5 ÷ 6 %
CO _{ma}	100 ppm	100 ppm

You may have to change the burner settings due to the fuel used and/or installation conditions (high altitude, air suction pipe with or without Snorkel, etc.) if combustion parameters are not correct.

When inspection tests are completed, the hole drilled for the probe must be sealed with a material that is resistant to high temperatures and that ensures the tube remains airtight.

5. OPERATING INSTRUCTIONS

5.1. START

To start the heater:

- Raise panel (n) on the electrical panel box;
- Make sure the switch (a) is set to “0”;
- Supply electrical power to the space heater by pulling up the disconnecting switch on the electric power panel: the green lamp (b) will light up indicating that power is being supplied to the panel;
- Turn switch (a) to position H or H+V: the burner will begin the start-up and pre-wash cycle, after which the flame will ignite; after the combustion chamber has been heating for a few minutes, the main fan will start up;

Warning



The fan runs continuously in H+V mode, even when the desired room temperature has been reached, and the burner turns off.

Warning



In H mode, the fan only runs when the combustion chamber is sufficiently hot. Therefore, when the desired room temperature has been reached, the burner turns off and the fan keeps running only until the combustion chamber has cooled completely.

- If the heater does not work during the start cycle or work cycle, consult “TROUBLESHOOTING” to find the cause of the malfunction.

Warning



If the burner goes into safety stop (lamp m) push reset button (d) for 3 seconds to restart the heater..

Warning



If the safety thermostat goes into safety stop (lamp h), push reset button (i) for 3 seconds to restart the heater.

Warning



NEVER do more than two restarts in a row: unburned fuel can accumulate in the combustion chamber and suddenly flare up at the next restart.

5.2. STOP

Stop the heater by turning switch (a) to “0” position or, if the heater is in automatic mode, by setting the room thermostat to a lower temperature: the burner shuts off and lamp (f) goes out. The fan keeps working, starting and stopping several times until the combustion chamber has cooled completely.

Warning



Never stop the heater by simply turning off the disconnecting switch on the panel.

The electrical supply must be disconnected ONLY when the

Warning



Never stop the heater by simply turning off the disconnecting switch on the panel.
The electrical supply must be disconnected **ONLY** when the fan has come to a complete stop.

5.3. VENTILATION

To run the heater only in continuous ventilation mode, turn switch (a) to the position with the symbol V.

5.4. TEMPERATURE CONTROLLER

The heater is equipped with a temperature controller (g) with LCD screen, which displays and controls the following parameters:

- Display of air outflow temperature
- Display of hours of operation
- Control of trip temperature of fan thermostat
- Control of trip temperature of burner thermostat

Display of air outflow temperature

The screen displays the measured temperature in [°C]:

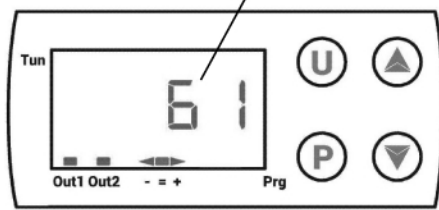

Display of hours of operation

Press key (a) twice: the screen shows the operating time in hours [h]:

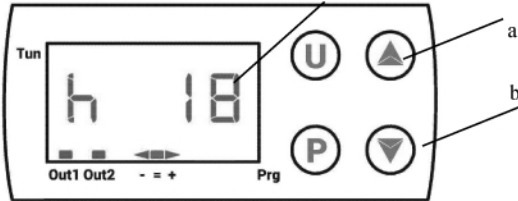

Warning



The time shown is not actual heating time, but connection time to the electrical power supply line.

Reset the counter as follows:

- Turn the heater's main switch to position "0" (OFF)
- Press button P on the temperature controller for at least 3 seconds: the word "PASS" will flash for 5 seconds
- Enter code "-481" by pressing key (b) several times until obtaining the number required; press key P to confirm and go to the next number
- Lastly, press key U: the display again shows the air outflow temperature

Control of trip temperature of fan thermostat

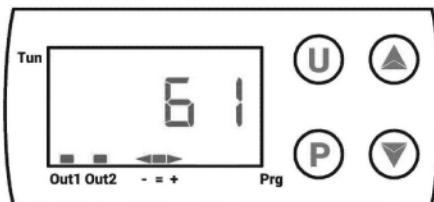

The temperature controller is programmed to start and stop the main fan automatically when the combustion chamber reaches the set temperature. This prevents cold air from blowing when the burner starts and the combustion chamber is not yet hot enough, and ensures that residual heat in the heater is dissipated when the burner stops.

The temperature is factory-set to 35°C, with hysteresis of 5°C.

Red LED "OUT 1" shows the operating state of the fan thermostat:

- LED ON: the fan is on
- LED OFF: the fan is off

Control of trip temperature of burner thermostat

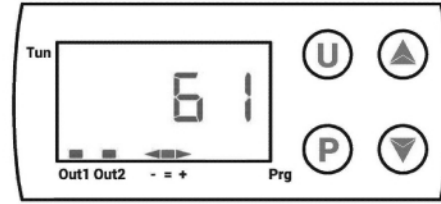

The temperature controller is programmed to start and stop the burner automatically when the combustion chamber reaches the set over-temperature. This prevents excessive overheating of the combustion chamber and subsequent tripping of safety thermostat L2, which blocks operation of the heater (see chapter 7 for details on operating problems that cause tripping of safety thermostat L2).

The temperature is factory-set to 95 °C, with hysteresis of 5°C.

Red LED "OUT 2" shows the operating state of the burner thermostat, while the LED group "- = +" indicates the current temperature compared to the set temperature:

- if the red arrow at the symbol "-=" is ON, it means that the temperature is below the set value and, therefore, the thermostat is ON, i.e., the burner is ON.
- if the green LED at the symbol "=1" is ON, it means that the temperature is at the set value.
- if the red arrow at the symbol "+=" is ON, it means that the temperature is above the set value and, therefore, the thermostat is OFF, i.e., the burner is OFF.

Warning



The trip temperatures of the fan thermostat and burner thermostat should be changed only if absolutely necessary. Contact the manufacturer for information needed to reprogram the temperature controller..

6. MAINTENANCE

Warning



All of the operations described in this section must be performed by professionally qualified personnel only.

The following procedures must be done at regular intervals to ensure efficient operation of the heater. Make sure you have detached the electrical power line from the heater before starting any work.

Warning



Before doing any maintenance:

- Stop the heater as indicated in the “STOP” paragraph;
- Switch off the power supply by means of the cut-off on the electrical panel;
- Wait until the heater cools.

Procedure	Periodic maintenance			
	Every day	Every week	Every six months	Every year
Check heater	X			
Check gas supply line	X			
Clean exterior of heater	X			
Clean motor and fan		X		
Check gas supply pressure		X		
Check electrical connections			X	
Check and test burner			X	
Check thermostats			X	
Clean interior of heater			X	
Inspect and clean combustion chamber				X

6.1. CHECKING THE HEATER AND THE GAS SUPPLY LINE

Perform the following checks:

- Make sure the heater is not installed where there may be a risk of fire or explosion
- Make sure that flammable materials are kept a safe distance away
- If you smell:
 - Open the windows immediately
 - Do not touch electrical switches
 - Close the gas stopcock
 - Find and repair the source of the gas leak
- Do not use the heater if any removed panels have not been remounted
- Make sure the room to be heated is sufficiently ventilated
- Make sure that the air intake and outlet are completely unobstructed
- Make sure that the heater is not covered by any sheets or covers;
- Check that the heater is in a fixed and stable position;
- Make sure the heater is constantly monitored during operation and checked before being started

6.2 CLEANING THE EXTERIOR OF THE HEATER

To ensure efficient operation, clean the following parts:

- Burner:
 - Remove all external dirt and debris
 - Make sure the air inlet is not obstructed.
- Pipes, connectors and joints:
 - Clean with a cloth.
- External body:
 - Clean with a cloth.
- Air inlet/outlet:
 - Remove all dirt and debris
 - Make sure the air inlet is not obstructed.

6.3 Cleaning the motor and the fan

Clean the fan blades and the motor as follows:

- Remove the fan group fixing screws and then remove the fan group.
- Clean the motor with compressed air.
- Clean the fan blades with a hard brush.

- Reinstall the fan group.

6.4 CHECKING THE ELECTRICAL CONNECTIONS

After detaching the power cable, check all electrical connections as follows:

- Make sure that all connections are complete and tight.
- If there are traces of dirt or corrosion, clean or replace the connections if necessary.
- Replace any damaged wires or connectors if necessary.

6.5 CHECKING AND TESTING THE BURNER

To reach the burner:

- Remove the burner fixing screw.
- Remove the burner and follow the checking and cleaning instructions in the burner manual.
- Reinstall the burner.
- Run the procedures described in paragraphs 4.7 and 4.8 to measure combustion parameters and check that combustion is stable and clean.

6.6 CHECKING THE THERMOSTATS

Inspect the thermostats as follows:

- Remove any air outlet connection ducts
- Find the thermostats fixed to the internal panel of the space heater.
- Clean with a dry cloth, taking care not to cut or bend the capillary tube.

6.7 CLEANING THE INTERIOR OF THE HEATER

For thorough cleaning, the heater can be cleaned and washed inside and outside with water. It is however necessary to ensure that:

- the electrical cable is disconnected and unplugged from the socket
- completely close all access panels
- do not use water jets at a pressure exceeding 70 bar at a distance less than 30 cm
- completely dry all parts before reconnecting the electrical cable.

6.8 CLEANING THE COMBUSTION CHAMBER

To maintain the burner's high efficiency and prolong its life, the procedure described in this paragraph must be done at least once at the end of the work season or more frequently if there is an excessive build-up of soot. Excessive soot may be caused by poor chimney draught, poor fuel quality, poor regulation of the burner, or more or less frequent alternation of burner starts and stops.

Pay attention during operation: pulsations at start may be due to excessive amounts of soot.

To access the heat exchanger (1), take off the rear panel (3), remove the smoke box inspection panel (2), and then remove baffle plates (7).

To access the combustion chamber (4) remove the burner (5).

Clean with compressed air or, if necessary, with a metal brush to remove any deposited soot and combustion residues.

Warning

After any technical work, always check that the heater works correctly.

7. TROUBLESHOOTING

In the event of serious anomalies, various safety devices are able to block the machine's operation and signal the same:

- on the electrical panel



the blocking signal following intervention by safety thermostat L2: the reset button is located inside the burner box.



(for three-phase models only) the blocking signal following

intervention by the motor thermal protection: the reset button is located inside the electrical panel.

- on the burner













the blocking signal following intervention by the burner's flame control box.

Warning

NEVER do more than two restarts in a row: unburned fuel can accumulate in the combustion chamber and suddenly flare up at the next restart.

If the heater is still not working properly, please contact your nearest dealer or authorized Service Centre.

FAULT	CAUSE	REMEDY
<ul style="list-style-type: none"> • The heater does not start:  lamp  is off	<ul style="list-style-type: none"> • No power supply 	<ul style="list-style-type: none"> • Check functioning and position of switch • Check the mains • Check power connections • Check fuse
<ul style="list-style-type: none"> • The heater does not start:  lamp  is on	<ul style="list-style-type: none"> • Switch (a) in wrong position 	<ul style="list-style-type: none"> • Select correct position
	<ul style="list-style-type: none"> • Incorrect functioning of the room thermostat 	<ul style="list-style-type: none"> • Check that thermostat connection plug is inserted • Check thermostat electrical connection • Check thermostat setting and correct it • Check functioning of thermostat
	<ul style="list-style-type: none"> • Gas pressure switch tripped due to no gas or insufficient pressure 	<ul style="list-style-type: none"> • Check that gas feed pipe has been bled • Check gas feed pressure
<ul style="list-style-type: none"> • The burner goes on and off alternately and LED OUT 2 on the temperature controller remains ON. 	<ul style="list-style-type: none"> • Insufficient gas supply 	<ul style="list-style-type: none"> • Check and clean gas filter. • Clean and recalibrate the burner.
	<ul style="list-style-type: none"> • Incorrect setting of burner 	<ul style="list-style-type: none"> • Clean and recalibrate the burner.
<ul style="list-style-type: none"> • The burner goes on and off alternately and LED OUT 2 on the temperature controller is OFF when the burner goes off. 	<ul style="list-style-type: none"> • Burner thermostat has tripped due to overheating 	<ul style="list-style-type: none"> • Check correct position of air distribution channels and opening of any flaps, openings, etc. • Remove any foreign bodies trapped in the air ducts or ventilation grilles
<ul style="list-style-type: none"> • The heater does not work:  the lamp  on the electrical panel is on	<ul style="list-style-type: none"> • Manual reset safety thermostat has tripped due to excessive overheating of combustion chamber 	<ul style="list-style-type: none"> • Check that the fan motor starts correctly and is not obstructed • Check that the fan motor is not burned out or that the motor condenser is not broke • Check burner calibration • Check the path and correct discharge of fumes
<ul style="list-style-type: none"> • The heater does not work:  the lamp  on the electrical panel is on	<ul style="list-style-type: none"> • Motor thermal protection has tripped due to excessive electrical power absorption 	<ul style="list-style-type: none"> • Remove any foreign bodies trapped in the air ducts or suction grilles • Check that the air distribution channels are not too lo
<ul style="list-style-type: none"> • The heater does not work::  the lamp  on the burner is steady on	<ul style="list-style-type: none"> • Burner's safety equipment has tripped 	<ul style="list-style-type: none"> • Refer to the burner manual for diagnosis and causes
<ul style="list-style-type: none"> • Fan noise or vibrations 	<ul style="list-style-type: none"> • Foreign bodies on fan blades • Insufficient air circulation 	<ul style="list-style-type: none"> • Remove foreign bodies • Eliminate all possible obstacles to proper air flow
<ul style="list-style-type: none"> • Insufficient heating 	<ul style="list-style-type: none"> • Insufficient burner capacity 	<ul style="list-style-type: none"> • Contact Customer Service

WIRING DIAGRAM

240V, 1 ~, 60Hz

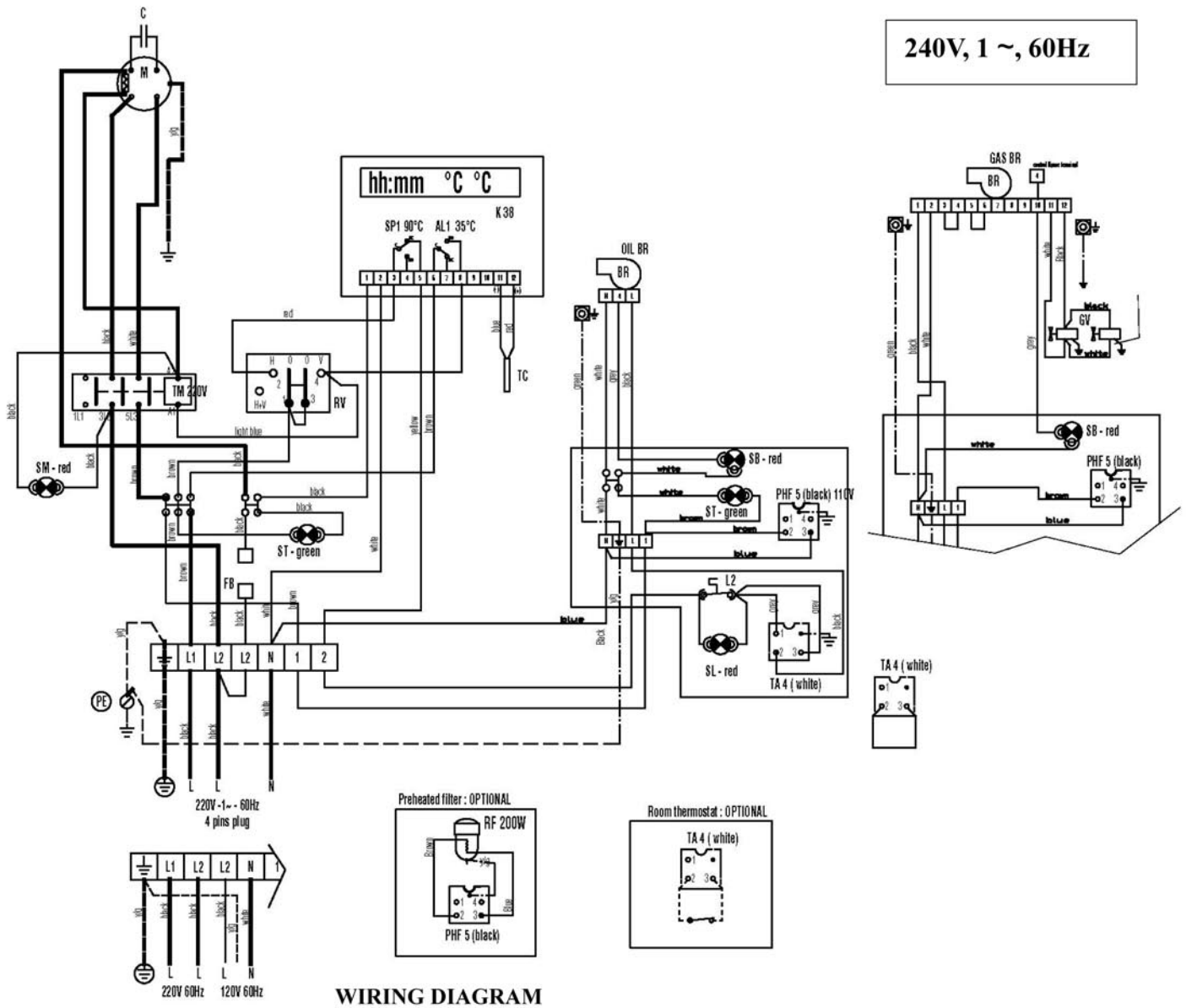

WIRING DIAGRAM

- M** FAN MOTOR
- F** FAN THERMOSTAT (setting: 30°C)
- FB** FUSE
- ST** POWER LAMP
- L2** LIMIT THERMOSTAT WITH MANUAL RESTART
- RV** HEATING-STOP-VENTILATION SWITCH
- SL** OVERHEAT THERMOSTATS CONTROL LAMP
- L1** BURNER THERMOSTAT (setting: 90°C)
- TA** ROOM THERMOSTAT PLUG
- RE2** DELAYED IGNITION RELAY
- R** ANTI-CONDENSATION RESISTANCE
- TM** FANS TELE-CONTACTOR
- RM** FANS THERMAL RELAY
- ST** POWER LAMP
- SM** FAN STOP LAMP
- BR** BURNER
- PB7** BURNER PLUG
- RV** HEATING-STOP-VENTILATION SWITCH

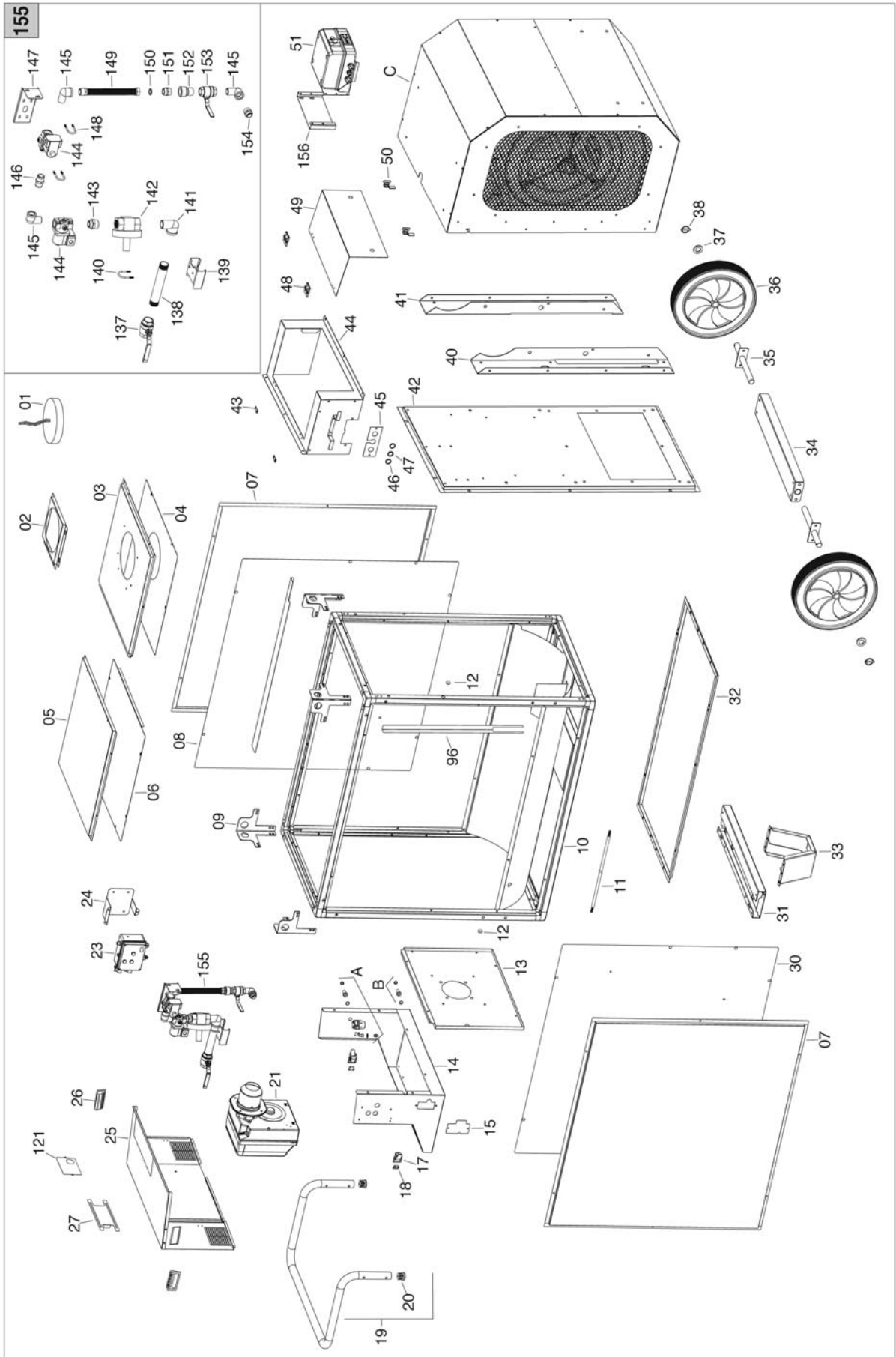

VG750 PARTS BREAKDOWN

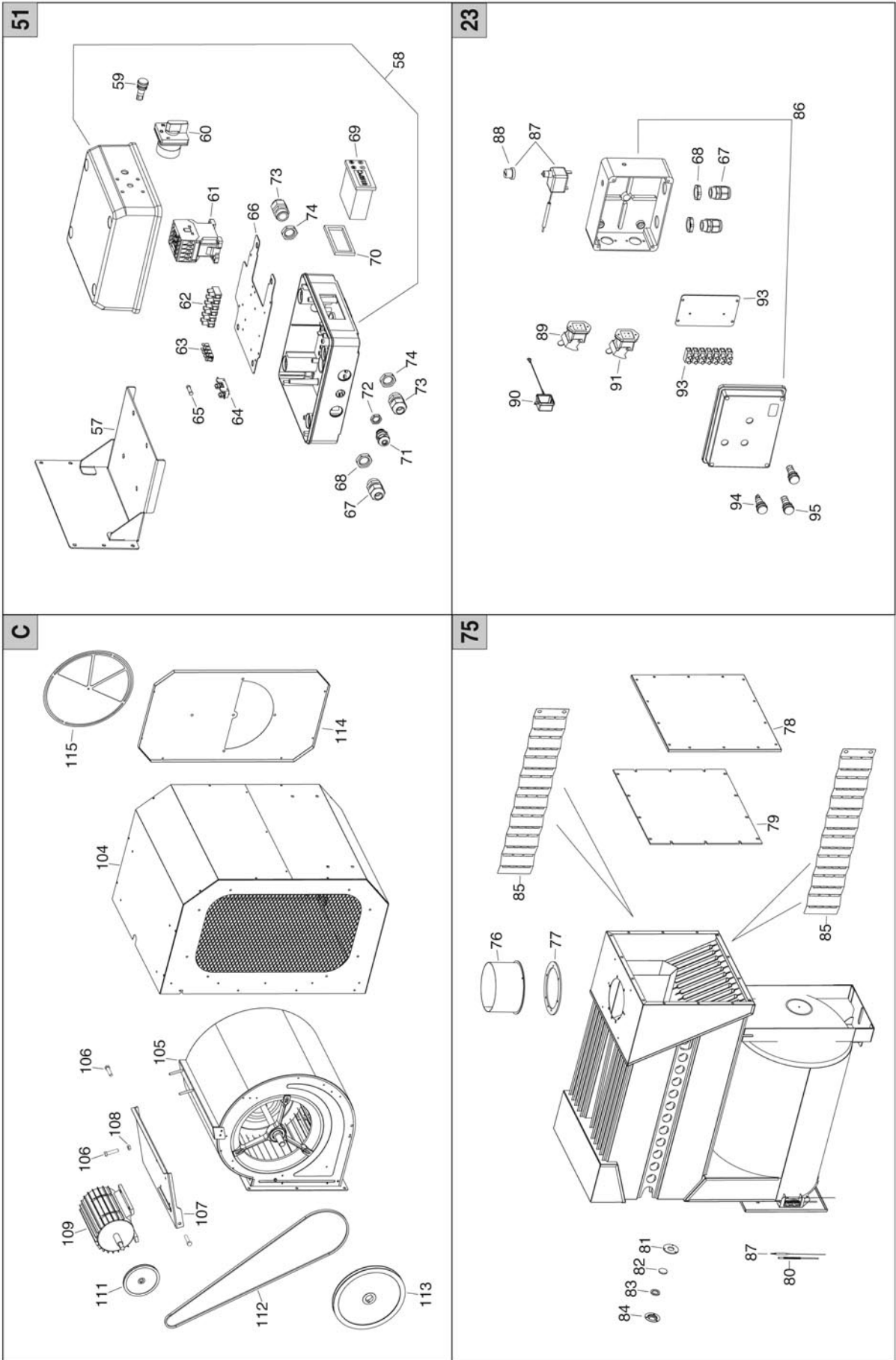

POS	P/N	DESCRIPTION
01	C30400-10	Cap
02	G04360	Panel
03	G04514-9010	Panel
04	G04415	Panel
05	G04516-9010	Panel
06	G04517	Panel
07	G04518-9010	Panel
08	G04519	Panel
09	G04289	Stirrup
10	G04520-9005	Frame
11	E30482-2	Power cord
12	C30301	Cable protection
13	G04521-9005	Panel
14	G04568-9005	Base
15	G04370-9005	Panel
17	M20430	Toggle latch
18	M20431	Catch
19	P20318-9005	Handle
20	C30398	Cap
21	074B108	Gas burner
23	G00522	El. control box
24	G04371-9005	Thermostat support bracket
25	G04569-9010	Panel
26	C10209	Handle
27	G04563-9005	Panel
28	M30001	Spring
29	G04403-9005	Panel
30	G04523	Panel
31	G04405-9005	Support bracket
32	G04545-9005	Panel
33	G04378-9005	Support
34	G04407-9005	Wheels axle support bracket
35	G04380	Wheel axle
36	C10562	Wheel
37	M20111	Washer
38	M20505	Latched pin
40	G04524-9005	Support bracket
41	G04525-9005	Support bracket
42	G04526-9005	Panel
43	G04383	Spacer

POS	P/N	DESCRIPTION
44	G04527-9005	Electrical panel box
45	G04505-9005	Support plate
46	C30316	Hole cap
47	C30389	Cable protection
48	M20432	Hinge
49	G04528-9005	Panel
50	M20418	Lock
51	G00521	El. control box
57	G04387-9005	Stirrup
58	E20725-03	El. components box
59	E11033	Lamp
60	E10141	Switch
61	E10455	Contact
62	E20301	Terminal board
63	E20319	Ground terminal board
64	E20508	Fuse holder
65	E10307	Fuse
66	G04388	Support plate
67	E20959	Cable fastener
68	E20960	Cable fastener nut
69	E50794	Thermoregulator
70	E50794-1	Seal
71	E20933	Cable fastener
72	E20956	Cable fastener nut
73	E20970	Cable fastener
74	E20971	Cable fastener nut
75	G04582	Combustion chamber
76	G04413	Chimney fitting
77	T10805	Seal
78	G04530	Panel
79	T10802	Seal
80	E50794-2	Thermocouple
81	T10691	Insulating gasket
82	T10405	Tempered glass
83	T10692	Insulating gasket
84	G04298	Disc
85	G01759	Turbulence-generating grid
86	E20706-02	El. components box
87	E50749	Safety thermostat
88	E50750	Safety thermostat plastic profile
89	E20688	Plug
90	E20665	Thermostat plug cover
91	E20640	Thermostat plug
92	E20301	Terminal board
93	G04392	Support plate

POS	P/N	DESCRIPTION
94	E11033	Lamp
95	E11030	Lamp
96	G04531	Protective panel
104	G04532-9010	Fan box
105	T10704	Fan
106	M10234	Screw
107	G04533-9005	Support plate
108	M10714	Nut
109	E10683-220	Motor
111	C10943-28	Sheave
112	C10947	Belt
113	C10945-25	Sheave
114	G04534-9005	Panel
115	G04513-9005	Air adjustment shutter
120	C30376	Cable protection
121	G04565-9005	Panel
137	T30361	Gas manual valve
138	I25026	Iron fitting
139	G04566	Stirrup
140	M20921	Stirrup
141	I20349	Fitting
142	T30125	Pressure regulator
143	I20348	Fitting
144	T30123	Gas valve unit
145	I20346	Fitting
146	I20347	Fitting
147	G04567	Gas valve support bracket
148	M20920	Stirrup
149	I39117	Flex gas pipe
150	I39116	Seal
151	I20118	Brass fitting
152	I20350	Fitting
153	T30359-2	Gas selector valve
154	I20926-1	Fitting
155	074B213	Gas Train
156	G04586	Stirrup

VG1100 PARTS BREAKDOWN

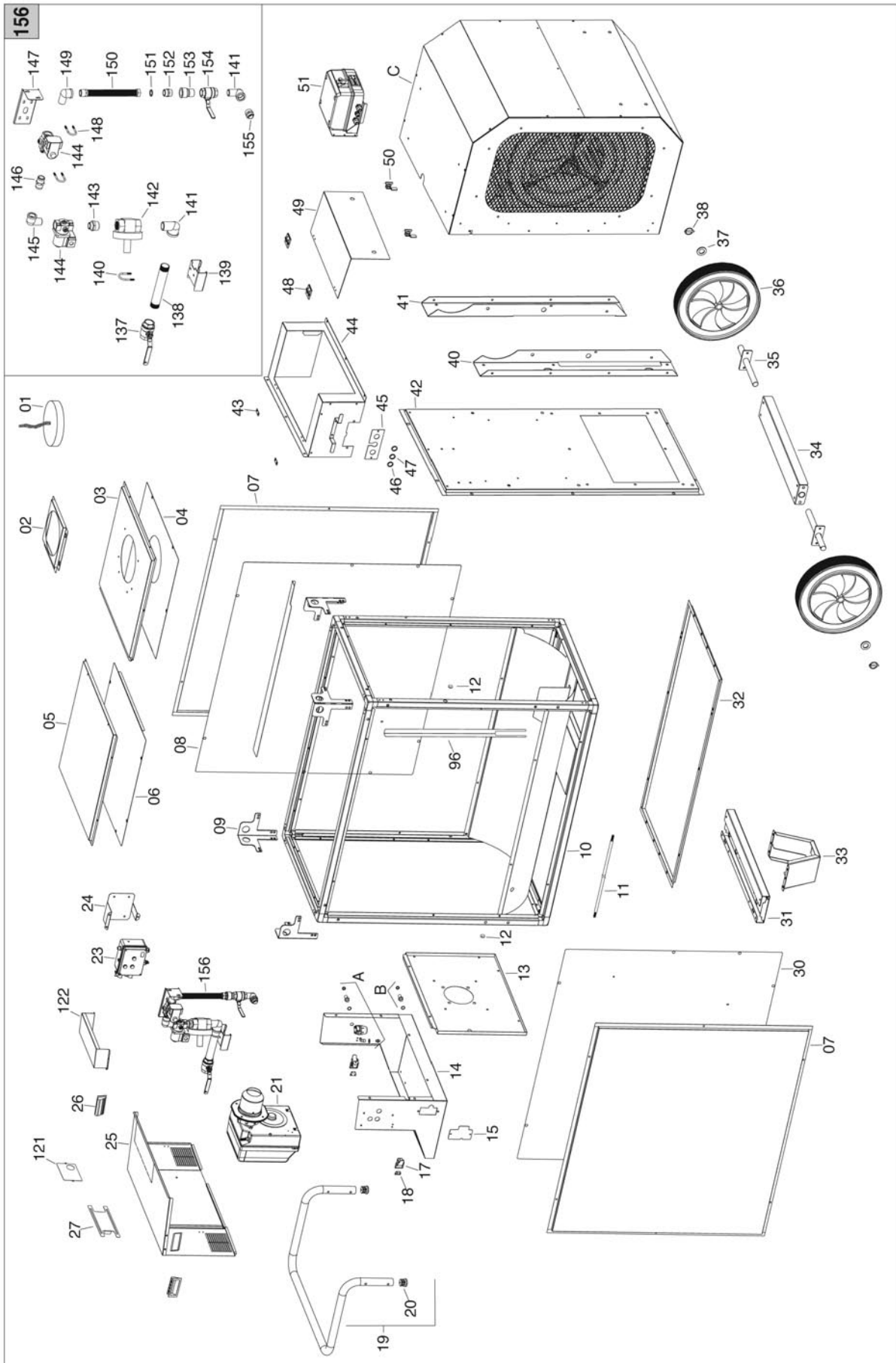

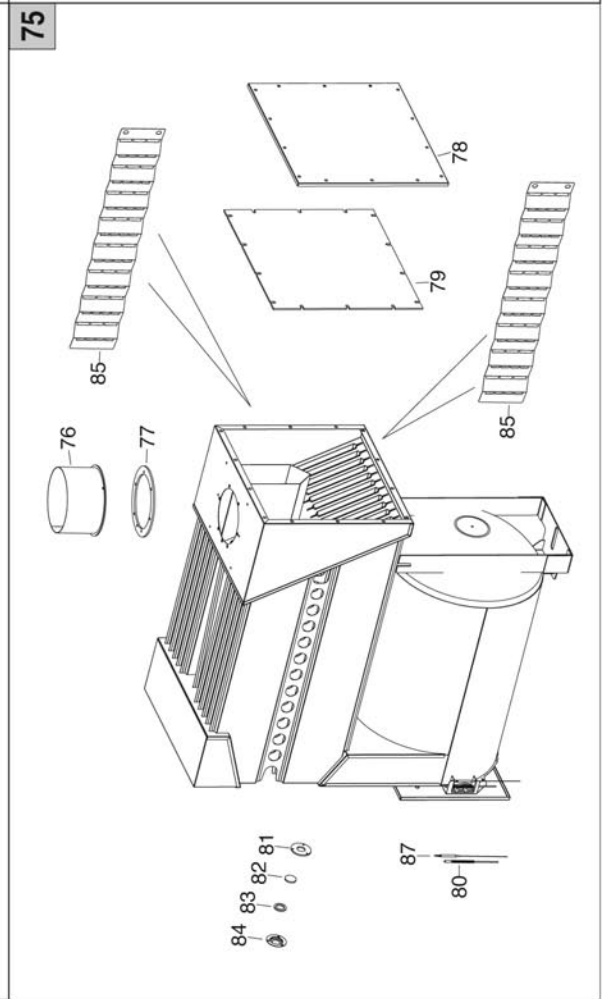
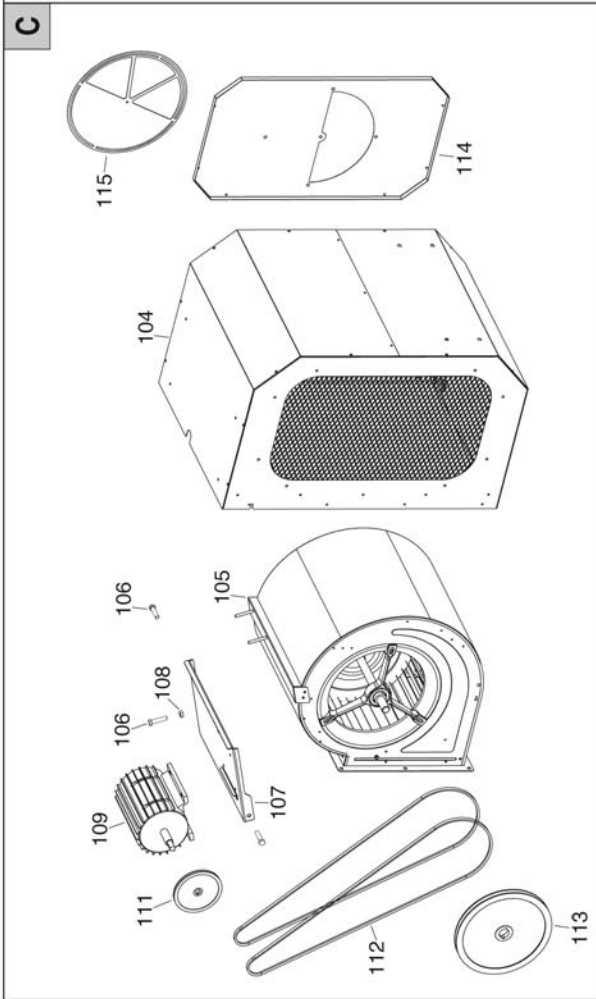
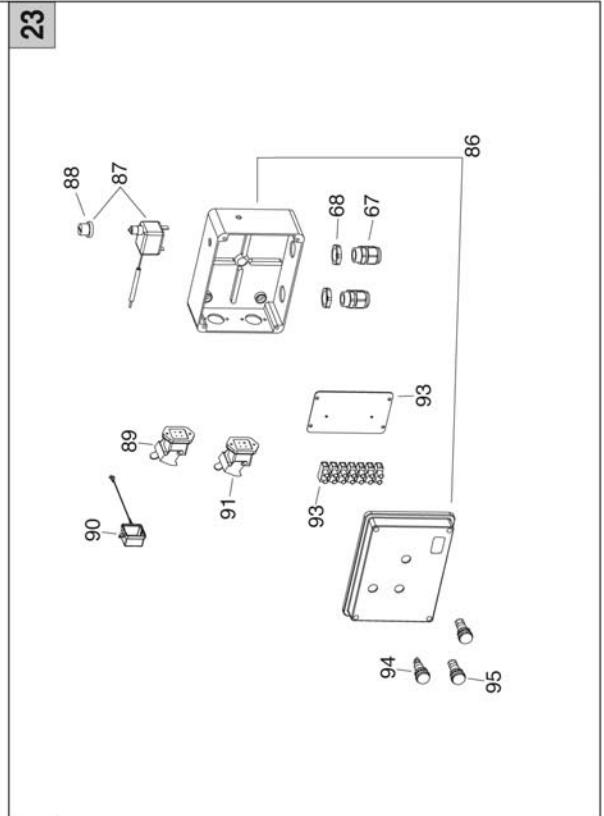
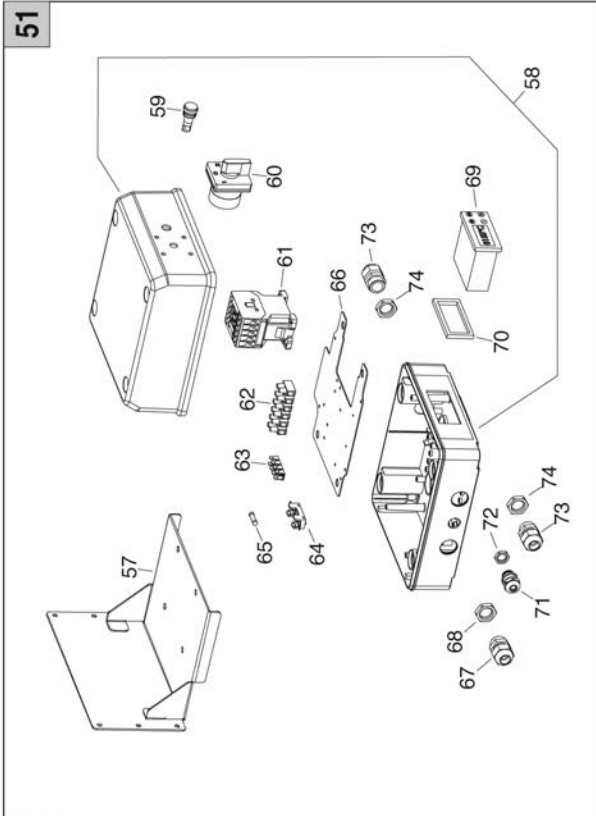

VG1100 PARTS BREAKDOWN

POS	P/N	DESCRIPTION
94	E11033	Lamp
95	E11030	Lamp
96	G04556	Protective panel
104	G04557-9010	Fan box
105	T10707	Fan
106	M10234	Screw
107	G04558-9005	Support plate
108	M10714	Nut
109	E10684-220	Motor
111	C10944-28	Sheave
112	C10948	Belt
113	C10946-25	Sheave
114	G04559-9005	Panel
115	G04513-9005	Air adjustment shutter
116	E11030	Lamp
117	E11172	Manual Motor Starter
118	E20347	Stirrup
119	E11165	Auxiliary contact
121	G04565-9005	Panel
137	T30361	Gas manual valve
138	I25026	Iron fitting
139	G04566	Stirrup
140	M20921	Stirrup
141	I20349	Fitting
142	T30124	Pressure regulator
143	I20348	Fitting
144	T30123	Gas valve unit
145	I20346	Fitting
146	I20347	Fitting
147	G04567	Gas valve support bracket
148	M20920	Stirrup
149	I20929	Fitting
150	I39118	Flex gas pipe
151	I39119	Seal
152	I20119	Brass fitting
153	I20351	Fitting
154	T30360-1	Gas selector valve
155	I20927-1	Fitting
156	074B213	Gas Train

POS	P/N	DESCRIPTION
44	G04552-9005	Electrical panel box
45	G04385-9005	Support plate
46	C30316	Hole cap
47	C30389	Cable protection
48	M20432	Hinge
49	G04553-9005	Panel
50	M20418	Lock
51	G00521	El. control box
57	G04387-9005	Stirrup
58	E20725-03	El. components box
59	E11033	Lamp
60	E10141	Switch
61	E10455	Contactor
62	E20301	Terminal board
63	E20319	Ground terminal board
64	E20508	Fuse holder
65	E10308	Fuse
66	G04388	Support plate
67	E20959	Cable fastener
68	E20960	Cable fastener nut
69	E50794	Thermoregulator
70	E50794-1	Seal
71	E20933	Cable fastener
72	E20956	Cable fastener nut
73	E20970	Cable fastener
74	E20971	Cable fastener nut
75	G04581	Combustion chamber
76	G04413	Chimney fitting
77	T10805	Seal
78	G04555	Panel
79	T10803	Seal
80	E50794-2	Thermocouple
81	T10691	Insulating gasket
82	T10405	Tempered glass
83	T10692	Insulating gasket
84	G04298	Disc
85	G01673	Turbulence-generating grid
86	E20706-02	El. components box
87	E50749	Safety thermostat
88	E50750	Safety thermostat plastic profile
89	E20688	Plug
90	E20665	Thermostat plug cover
91	E20640	Thermostat plug
92	E20301	Terminal board
93	G04392	Support plate

POS	P/N	DESCRIPTION
01	C30400-10	Cap
02	G04360	Panel
03	G04535-9010	Panel
04	G04536	Panel
05	G04537-9010	Panel
06	G04538	Panel
07	G04539-9010	Panel
08	G04540	Panel
09	G04289	Stirrup
10	G04541-9005	Frame
11	E30482-2	Power cord
12	C30301	Cable protection
13	G04560-9005	Panel
14	G04561-9005	Base
15	G04370-9005	Panel
17	M20430	Toggle latch
18	M20431	Catch
19	P20319-9005	Handle
20	C30398	Cap
21	074B110	Gas burner
23	G00522	El. control box
24	G04371-9005	Thermostat support bracket
25	G04562-3001	Panel
26	C10209	Handle
27	G04373-9005	Panel
30	G04544	Panel
31	G04376-9005	Support bracket
32	G04546-9005	Panel
33	G04547-9005	Support
34	G04379-9005	Wheels axle support bracket
35	G04548	Wheel axle
36	C10572	Wheel
37	M20111	Washer
38	M20505	Latched pin
40	G04549-9005	Support bracket
41	G04550-9005	Support bracket
42	G04551-9005	Panel
43	G04383	Spacer

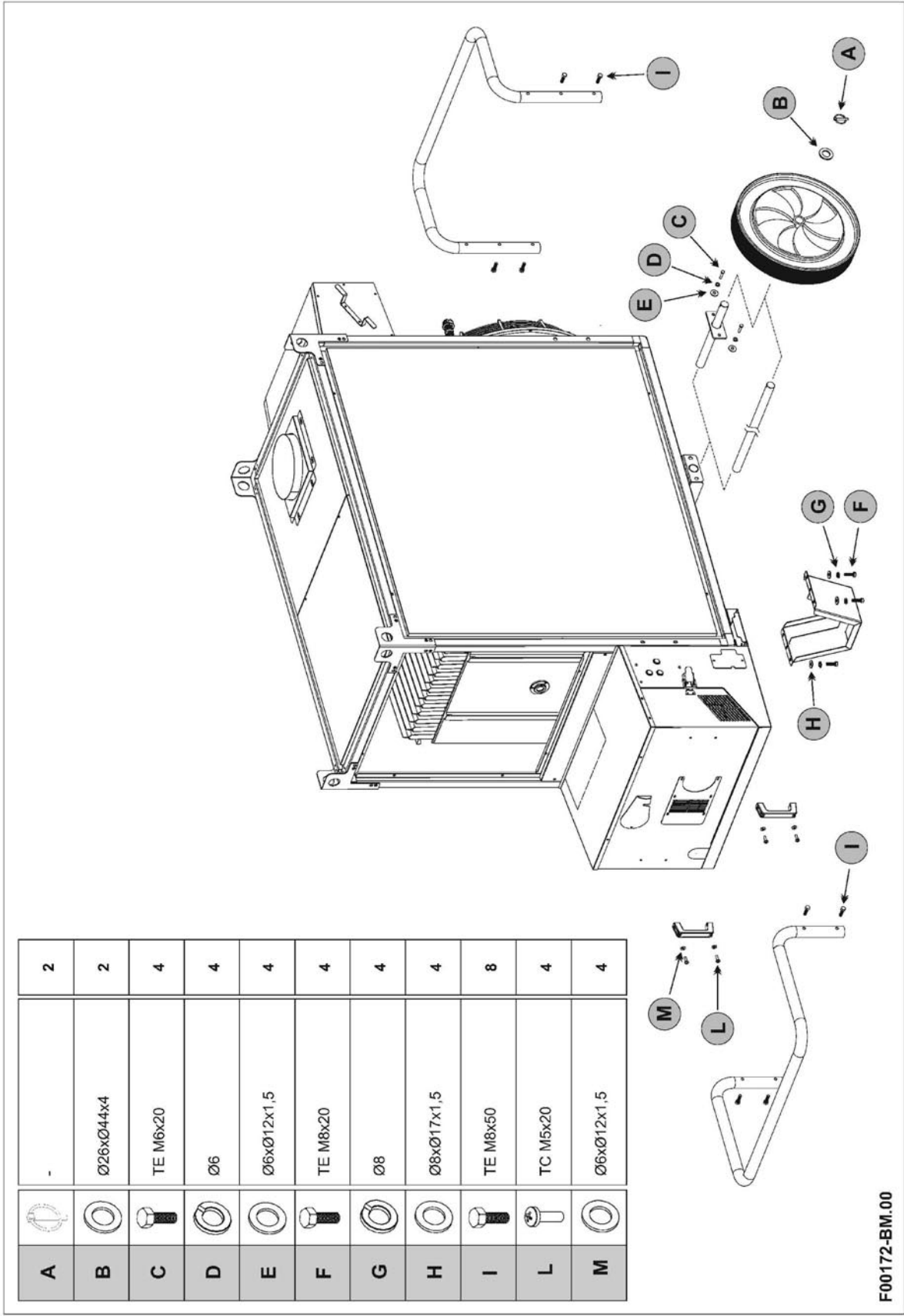

A		-	2
B		Ø26xØ44x4	2
C		TE M6x20	4
D		Ø6	4
E		Ø6xØ12x1,5	4
F		TE M8x20	4
G		Ø8	4
H		Ø8xØ17x1,5	4
I		TE M8x50	8
L		TC M5x20	4
M		Ø6xØ12x1,5	4

F00172-BM.00

TECHNICAL SPECIFICATIONS			VG750
Burner Model			RIELLO R40-N750S
Burner Nozzle			RIELLO G20
Natural gas	Normal altitude 0 - 2,000 ft above sea level (U.S.A. and Canada)	Supply pressure	[in w.c.] min 7" w.c. max 10" w.c.
		Heat input	[BTU/h] 740261
		Manifold pressure	[in w.c.] 2,80
		Burner head position	[N°] 5
		Burner Air setting	[N°] 5,3
	Altitude 2,000 - 4,500 ft above sea level (Canada only)	Heat input	[BTU/h] -
		Manifold pressure	[in w.c.] 2,34
		Burner head position	[N°] 5
		Burner Air setting	[N°] -
		Fuel consumption	[CFH] -
L.P.G.		Supply pressure	[in w.c.] min 8" w.c. max 13" w.c.
		Gas firing valve	[in] 0,472
	Normal altitude 0 - 2,000 ft above sea level (U.S.A. and Canada)	Heat input	[BTU/h] 751326
		Manifold pressure	[in w.c.] 2,08
		Burner head position	[N°] 5
		Burner Air setting	[N°] 5,3
		Fuel consumption	[CFH] 290,60
	Altitude 2,000 - 4,500 ft above sea level (Canada only)	Heat input	[BTU/h] -
		Manifold pressure	[in w.c.] -
		Burner head position	[N°] 5
Burner Air setting		[N°] -	
Fuel consumption		[CFH] -	
Air flow		[cfm]	9417,2
Fan Thermostat Setting		[°F]	95
Burner Thermostat Setting		[°F]	194
Power supply	Phase		1
	Voltage	[V]	240
	Frequency	[Hz]	60
Electric consumption		[W]	4000
		[A]	19,5
Flue diameter		[in]	7,87
Compulsory flue draft		[in]	0,05
Maximum air temperature		[°F]	250
Max. operating pressure elec. gas valve		[psi]	5
Air distribution duct	Max Static pressure	[in]	1,12
	Max length 1 way - dia 28"/26"	[ft]	150
	Max length 2 ways - dia 20"	[ft]	90
	Max length 3 way - dia 14"	[ft]	75
Inlet flexible duct	Max length 1 way - dia 28"	[ft]	30
Noise level at 1 m		[dBA]	70
Heater	Dimensions, L x W x H	[in]	98,78 x 36,22 x 63,78
	Weight	[lb]	948

TECHNICAL SPECIFICATIONS			VG1100
Burner Model			RIELLO R40-N900S
Burner Nozzle			RIELLO G20
Natural gas	Normal altitude 0 - 2,000 ft above sea level (U.S.A. and Canada)	Supply pressure	[in w.c.] min 7" w.c. max 10" w.c.
		Heat input	[BTU/h] 996801
		Manifold pressure	[in w.c.] 2,80
		Burner head position	[N°] -
		Burner Air setting	[N°] 8
	Altitude 2,000 - 4,500 ft above sea level (Canada only)	Fuel consumption	[CFH] 971,52
		Heat input	[BTU/h] 897121
		Manifold pressure	[in w.c.] 2,34
		Burner head position	[N°] -
		Burner Air setting	[N°] -
L.P.G.	Normal altitude 0 - 2,000 ft above sea level (U.S.A. and Canada)	Fuel consumption	[CFH] -
		Supply pressure	[in w.c.] min 8" w.c. max 13" w.c.
		Gas firing valve	[in] 0,472
		Heat input	[BTU/h] 1017795
		Manifold pressure	[in w.c.] 1,64
	Altitude 2,000 - 4,500 ft above sea level (Canada only)	Burner head position	[N°] -
		Burner Air setting	[N°] 8
		Fuel consumption	[CFH] 398,88
		Heat input	[BTU/h] -
		Manifold pressure	[in w.c.] -
Air flow	Burner head position	[N°] 5	
	Burner Air setting	[N°] -	
Air flow		[cfm]	11182,9
Fan Thermostat Setting		[°F]	86
Burner Thermostat Setting		[°F]	194
Power supply	Phase		1
	Voltage	[V]	240
	Frequency	[Hz]	60
Electric consumption		[W]	4300
		[A]	19,0
Flue diameter		[in]	7,87
Compulsory flue draft		[in]	0,05
Maximum air temperature		[°F]	250
Max. operating pressure elec. gas valve		[psi]	5
Air distribution duct	Max Static pressure	[in]	1,20
	Max length 1 way - dia 28"/26"	[ft]	150
	Max length 2 ways - dia 24"	[ft]	90
	Max length 3 way - dia 16"	[ft]	75
Inlet flexible duct	Max length 1 way - dia 29,5"	[ft]	30
Noise level at 1 m		[dBA]	70
Heater	Dimensions, L x W x H	[in]	107,20 x 41,02 x 72,40
	Weight	[lb]	948

BURNER DIMENSIONS

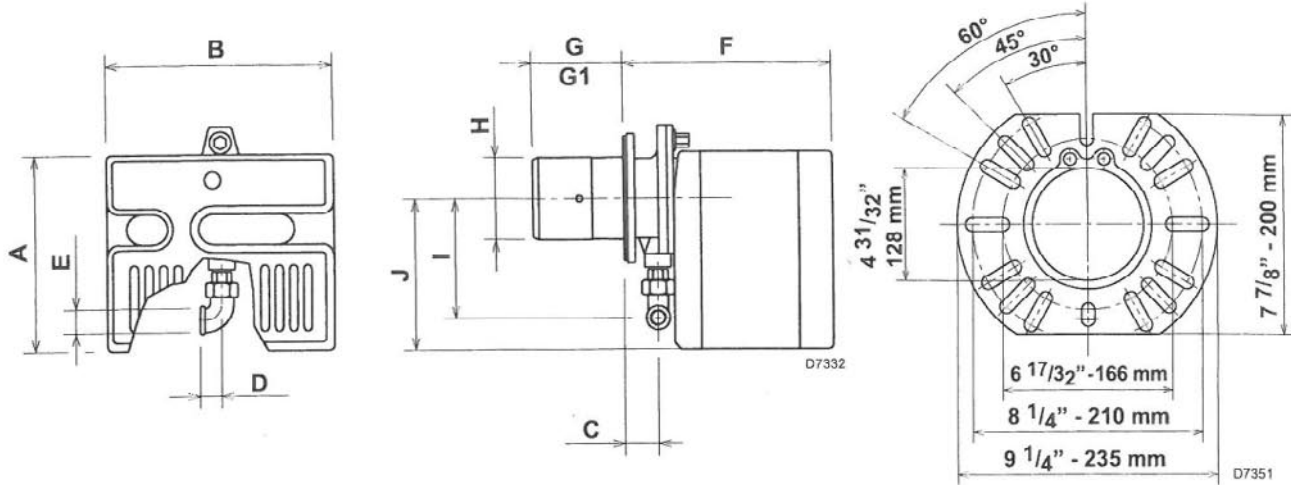

Model 750	A	B	C	D	E	F	G	G1	H	I	J
inches	11 ⁴⁷ / ₆₄	13 ²⁵ / ₃₂	2 ⁴¹ / ₆₄	1 ¹⁹ / ₆₄	³ / ₄	15 ²³ / ₆₄	4 ²³ / ₃₂	10 ⁵ / ₈	4 ⁵⁹ / ₆₄	5 ⁶³ / ₆₄	9 ¹ / ₁₆
mm	298	350	67	33	19	389	120	270	125	152	230

NOTE: Actual available insertion length must be measured from tip of end cone to face of mounting gasket.

ELECTRODE AND FLAME PROBE ADJUSTMENTS

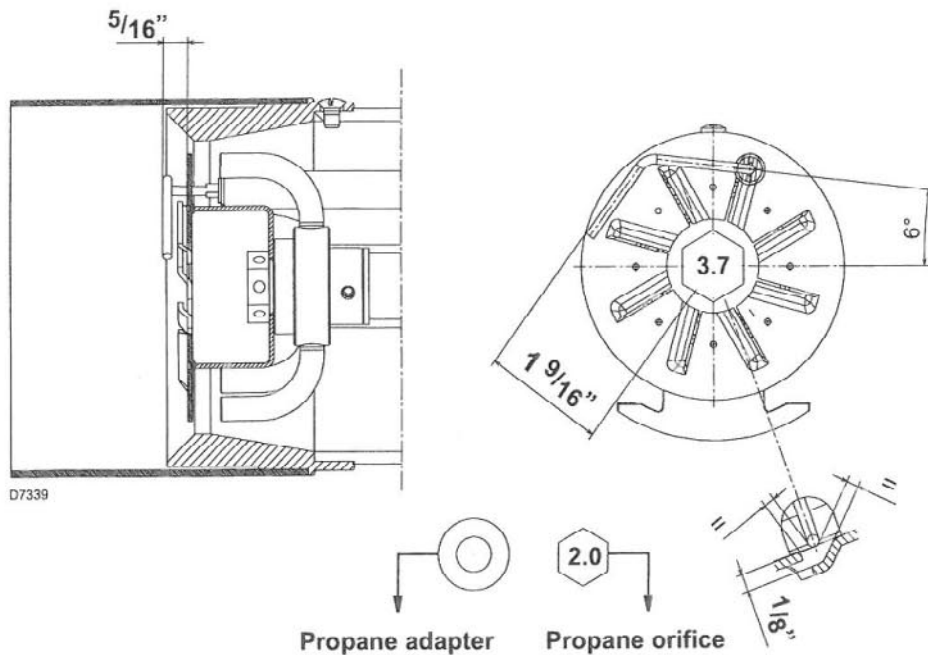

Do not turn the ignition electrode. Leave it as shown in the drawing.
If the ignition electrode is put near the ionization probe, the amplifier of the control box may be damaged.

RIELLO

TYPICAL GAS TRAIN LAYOUT (See page 7 for actual manifold assembly)

This gas train scope of supply meets the minimum controls requirements according to CGA and AGA regulations. Any additional requirements needed to meet local codes are the responsibility of others.

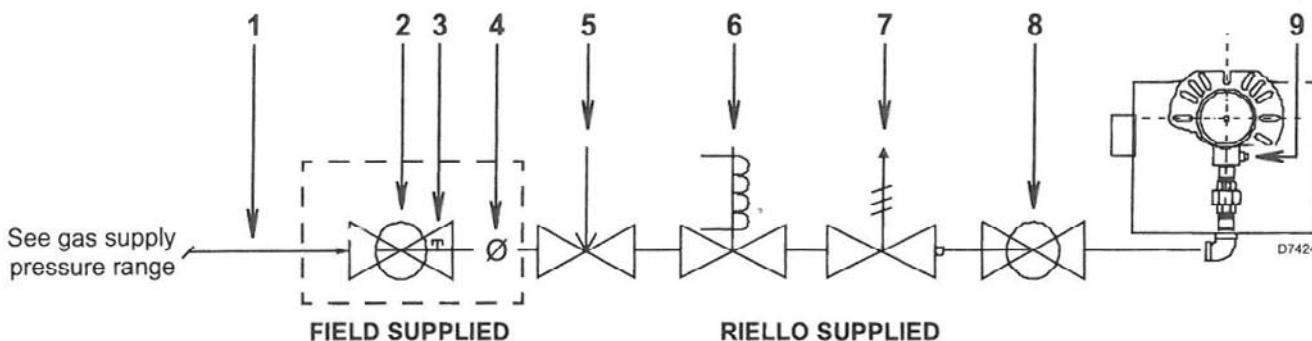

NOTE: ITEMS 5, 6 & 7 COMBINATION GAS VALVE(S) ASSEMBLIES MAY BE UTILIZED WHERE APPROVED

Key to layout

- 1 Gas supply & flow direction of gas *
- 2 Gas supply main shutoff manual valve (field supplied) (T30361)
- 3 Gas supply pressure test point - (field supplied)
- 4 Gas train pipe diameter size(s): burner G750 1" NPT (reduced at combustion head to 3/4")
- 5 Gas appliance pressure regulator -T30125
- 6 Safety shutoff gas valve (VS) 120V operated - (T30123)
- 7 Main gas valve 120V operated: (T30123)
burner G750 = single stage V1 only -
- 8 Firing valve manual shutoff (Gas Selector -T30359-2)
- 9 Gas burner manifold test point (gauge installed)

Gas supply pressure ranges	min.	max.
Natural gas	7" wc	10" wc
Lp propane gas	8" wc	13" wc

* If max 14" W.C. gas supply exceeded recommend 11SV08 regulator.

INSTALLING THE BURNER

- A) Burner chassis
- B) Combustion head assembly
- 1) Locking nut
- 2) Mounting plate surface
- 3) Insulation gasket

Separate the combustion head of the burner from the chassis (A) by removing the locknut (1). Install the combustion head into the boiler.

Typical insertion depth, the front edge of the combustion head is flush with the inside surface of the appliance mounting surface (2).

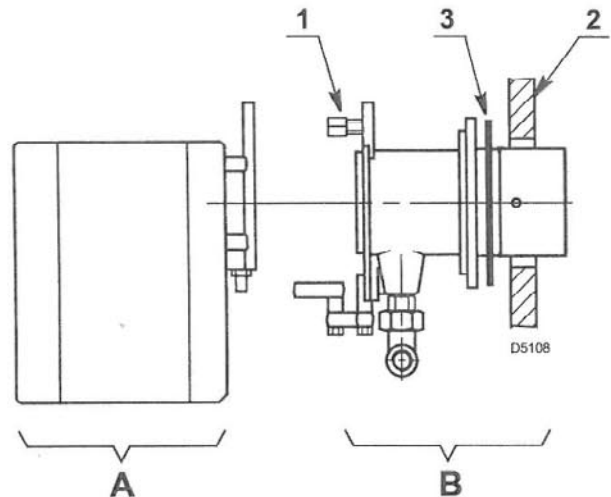

Use this checklist prior to installation:

- 1) Check the input/output requirements of the boiler/furnace.
- 2) Check the physical size of the combustion chamber against the thermal requirements of the application and relate this to the sizing charts.
- 3) Check that there is sufficient air for proper combustion and adequate ventilation. Local codes should be followed. Check that you have adequate space for servicing the equipment. Riello Burner requires a minimum of 13 inches clear space behind the red cover. This is required to allow easy removal of the cover for servicing and periodic maintenance.
- 4) Check that the chimney is of sufficient area to handle the exhaust gases. Make sure that the chimney is clear and there are not obstructions. Barometric draft regulators, when used, should be of the double acting type, and must be installed in accordance with the draft regulator Manufacturer's instructions. Single acting barometric dampers are not permitted.
- 5) Affix the supplied operating instructions label to the burner. This label reads as follows:

TO START THE BURNER:

Switch on power, open manual gas cocks, set the thermostat above ambient temperature. If the burner does not start, press the illuminated re-set button on the burner safety control.

TO SHUT DOWN BURNER:

Switch off power supply. If burner is switched off for extended periods, close manual gas cocks.



A vent shutoff system shall be applied to a barometric damper installed in the venting system at the time of conversion of the appliance. This will electrically disconnect the burner should there be a blockage in the vent (chimney).

The installer must identify the main electrical power switch and manual gas shut off valve, for emergency conditions. The burner cover must be in place and secured before the burner is placed in operation.

INSTALLATION OF SEDIMENT TRAP AND BURNER SUPPLY

Gas piping to the burner must be 1/2-inch minimum. Install only a full-ported shutoff valve. The valve must be located outside the appliance jacket, and the pressure gauge port must be accessible.

PRESSURE TEST-OVER 1/2 PSIG.

The appliance and its individual shutoff valve must be disconnected from the gas supply piping system during any pressure testing of the system at a test pressure in excess of 1/2 PSIG.

PRESSURE TEST-1/2 PSIG OR LESS

The appliance must be isolated from the gas supply piping system by closing its individual manual shutoff valve during any testing of the gas supply piping system at test pressures equal to or less than 1/2 PSIG.

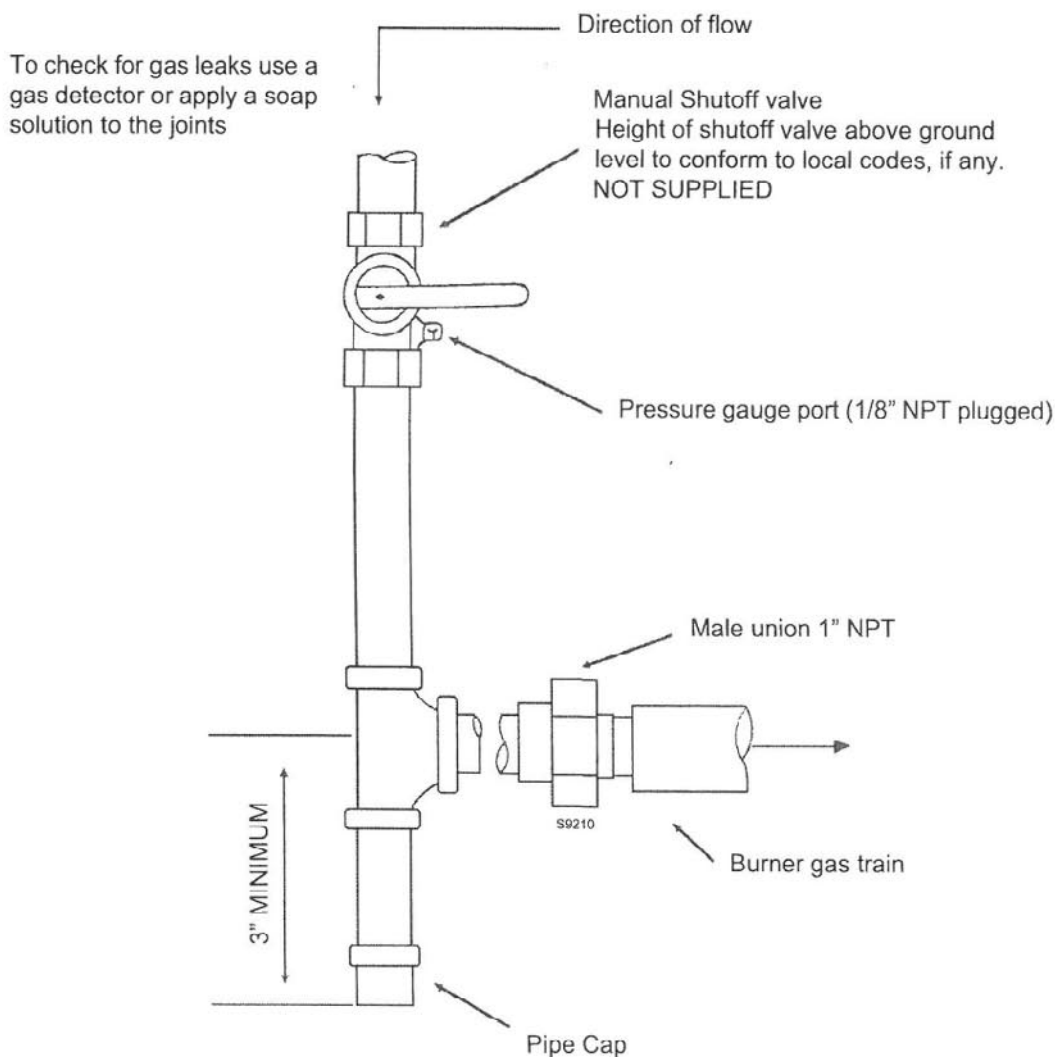

FACTORY WIRING DIAGRAM

CONTROL CIRCUITS

Burner operation may be controlled by either 120V or 24V control systems.

The required controls must be connected to the burner as described on the following.

120V CONTROL SYSTEM

The burner provides its own power supply for the control circuits that is switched internal from terminal 1(X12)(L) & 2(X12)(N), do not apply power on any other terminal or damaged to the control could occur.

24V CONTROL SYSTEM

If firing is to be controlled by a 24V operating system a 24V switching relay wired as shown in the diagram is required (not supplied – sold separately).

The required 24V operating controls must be wired between the thermostat terminals on the 24V-switching relay.

NOTE

If an external electrical source is utilized, the conversion burner, when installed, must be electrically grounded with a solid green wire to Earth Ground, in accordance with local codes or, in the absence of local codes, with the National Electrical Code ANSI/NFPA 70-1990 and the CSA Electrical Code.

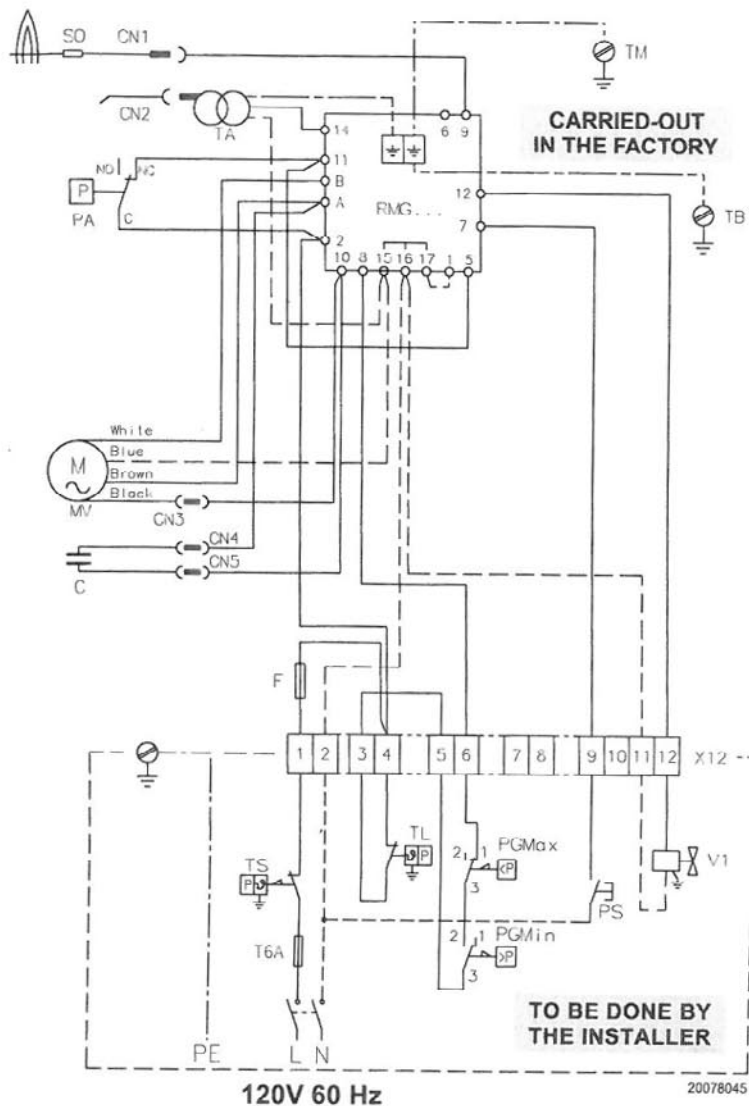

120V 60 Hz

20078045

24V CONTROL SYSTEM

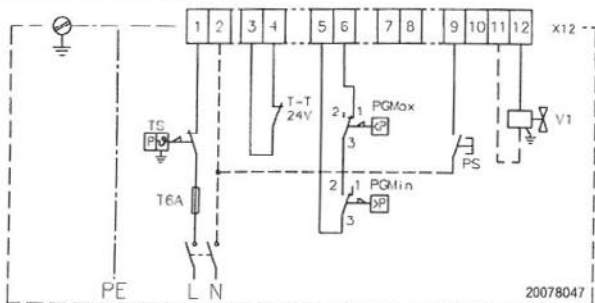

20078047

120V CONTROL SYSTEM

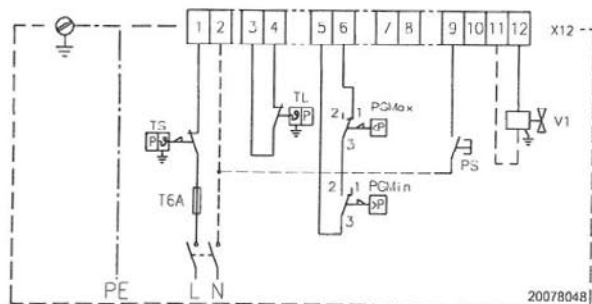

20078048

Key to lay-out

- C Capacitor MV
- F Fuse 6.25A
- CN... Connectors
- MV Fan motor
- PA Air pressure switch
- PGMax Max gas pressure switch

- PGMin Min gas pressure switch
- PS Remote reset push-button
- RMG... Control box
- SO Ionization probe
- TA Ignition transformer
- TB Burner earth
- TL Operating thermostat

- TM Earth terminal board
- TS High limit thermostat
- T-T 24V operating relay contact
- T6A Fuse
- V1 Gas valve
- X12 Terminal board 12 pole

RIELLO

COMBUSTION HEAD SETTING

To set combustion head, loosen the Allen screw (A) and move the elbow (B) so that the rear edge of the air tube (C) coincides with the set point number.

See firing rate chart for set points.

Retighten the Allen screw (A).

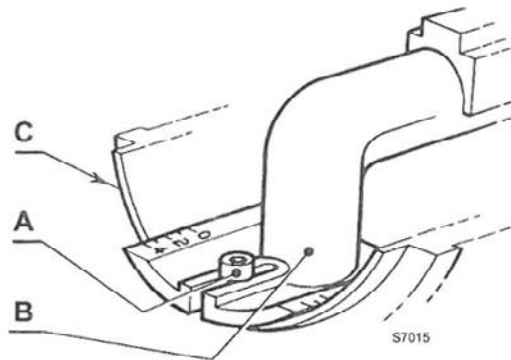

WARNING

Make sure you are using the correct table for either Natural gas or Propane gas.

BURNER SETUP CHART

	BTU Input	Air Gate	Stop Gate	Manifold Pressure	Line Pressure
NATURAL GAS	250,000	1.7	0.0	1.4" w.c.	8.0" w.c.
	350,000	1.6	0.0	1.6" w.c.	8.0" w.c.
	450,000	1.8	1.0	1.5" w.c.	8.0" w.c.
	550,000	2.2	2.0	1.4" w.c.	8.0" w.c.
	650,000	2.8	3.0	1.8" w.c.	10.0" w.c.
	750,000	3.5	4.0	2.1" w.c.	12.0" w.c.
PROPANE	250,000	2.0	0.0	1.0" w.c.	11.0" w.c.
	350,000	2.1	0.0	1.4" w.c.	11.0" w.c.
	450,000	3.0	1.0	1.5" w.c.	11.0" w.c.
	550,000	3.2	2.0	2.1" w.c.	11.0" w.c.
	650,000	3.7	3.0	2.6" w.c.	11.0" w.c.
	750,000	4.1	4.0	3.0" w.c.	11.0" w.c.

Line pressure measured at gas valve with burner firing.

NOTE:

The above settings are a starting point for adjustments ONLY; a qualified gas technician using proper test equipment must do the final adjustments.

Proper CO², O₂, and CO readings must be taken and be within regulating code requirements.

All the settings above are based on zero (0) over fire-draft.

If positive or negative chamber conditions exist some settings changes made be required.

For any referral to valve setting, please check the attached manufacturer valve specification.

AIR GATE ADJUSTMENT

To regulate the combustion air, adjust the manual air gate (3), by loosening the locking screws (4).
Once the optimal adjustment is reached, tighten the locking screws (4).

EXAMPLE SETTING - (for natural gas)

To set the air intake for a desired burner output of 450,000 Btu/hr, use **TABLE** to determine the correct air gate setting.
In this case, the setting would be 1.8 for natural gas.
Turn the manual air gate (3) until the arrow points to 1.8 on the scale.
Tighten locking screws (4).

All settings in **TABLE** are obtained with zero (0) pressure in the combustion zone and at normal operating temperatures. i.e., steady state hot conditions.

Note: Burner must be fired **ONLY** with fuel that is listed on the burner serial label.

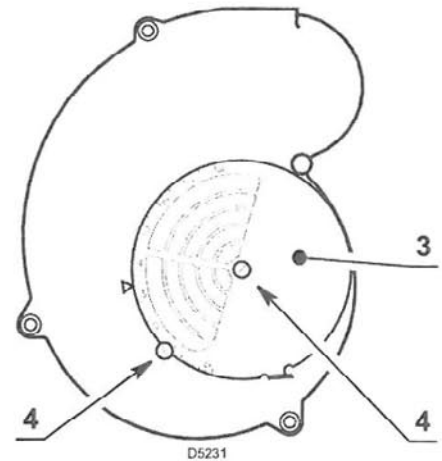

PRESSURE WORKING CHART

The chart below shows effects of pressure in the combustion zone on the minimum/maximum burner outputs.
In this example, with a maximum operating pressure of 1.2 inches water column in the combustion zone, you will be able to obtain a maximum of 600 KBTu/h burner output.

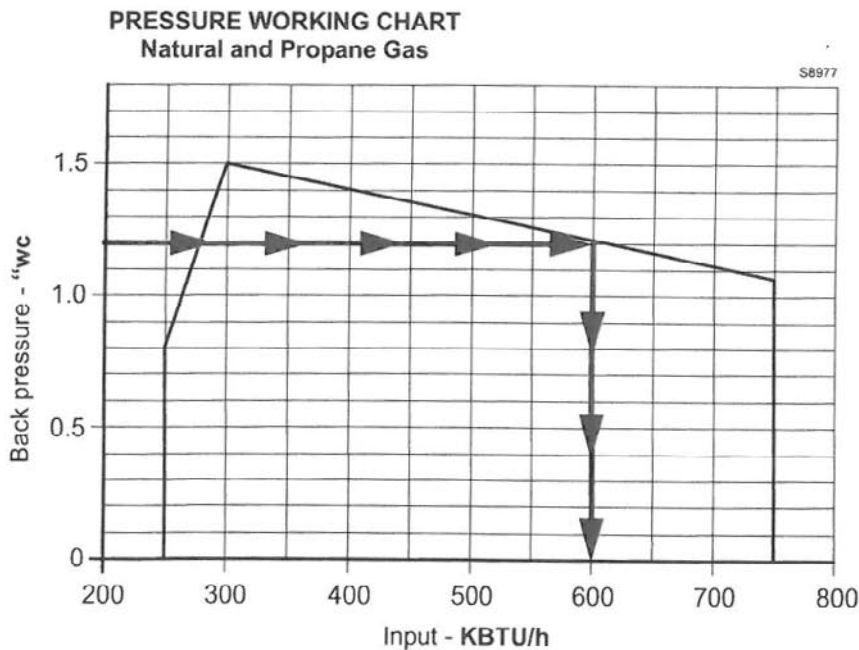

Any change from zero (0) pressure in the combustion zone will affect the KBTu output of the burner. To supply the required input to the appliance, manifold pressure will have to be adjusted to compensate for this condition.

COMBUSTION CHAMBER SIZE

COMBUSTION CHAMBER SIZE
Recommended Minimum Sizes

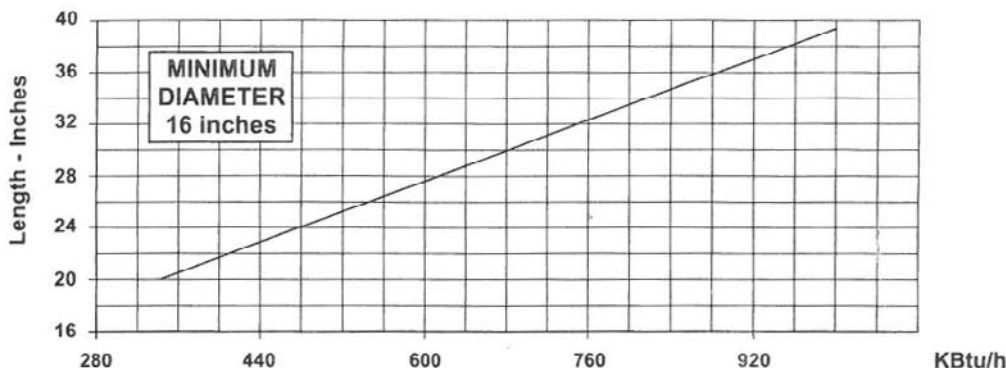

NOTES:

- 1) Sizes shown above are for cylindrical or wet base boilers, or air cooled heat exchangers.
- 2) To size the chamber in applications other than wet base boilers, you must calculate area in square inches of the combustion zone required to give you a grate area or floor area to match the BTU inputs according to local authority.
- 3) Recommended firebrick or cerafelt material has a continuous run limited to 2400 degrees Fahrenheit and a melting point of 3000 degrees Fahrenheit.

COMBUSTION CHECKS

CO₂ It is advisable not to exceed a measured reading of 10% CO₂ for Natural Gas or 12% CO₂ for Propane Gas taken with the burner cover in place, to avoid the risk of the formation of CO due to minor changes in wind/draft conditions which may occur.

CO For safety reasons, the value of .02% (200ppm) free air sample must not be exceeded.

IONIZATION CURRENT

The minimum amount of current necessary for the control box to operate properly is 5 micro Amps DC. To measure the ionization current, disconnect the red wire connector and insert a DC micrometer in series with control box terminal 9 and the ionization probe, which senses the flame.

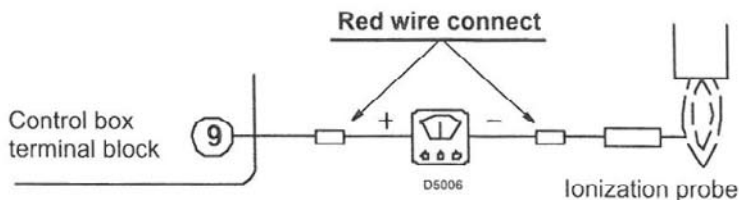

BURNER START-UP CYCLE

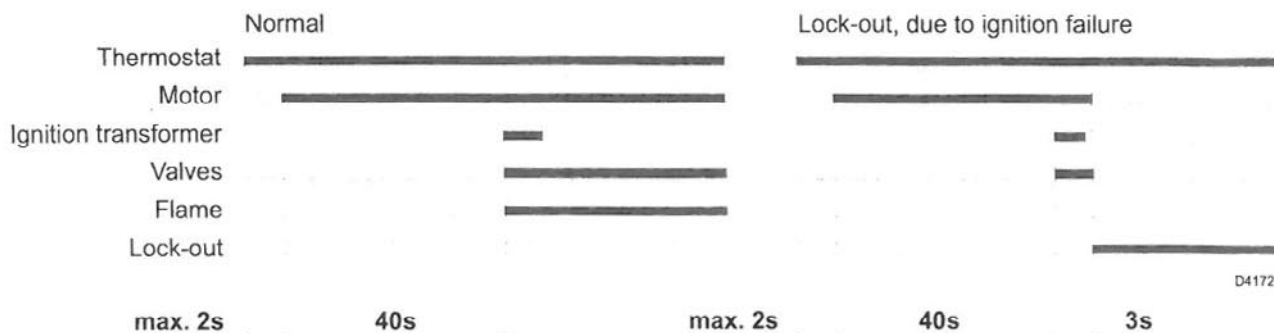

START-UP CYCLE DIAGNOSTICS

During start-up, indication is according to the following table:

COLOUR CODE TABLE	
Sequences	Colour code
Pre-purging	●●●●●●●●●●
Firing phase	●○●○●○●○●○
Operation, flame ok	□□□□□□□□
Operating with weak flame signal	□○□○□○□○□○
Electrical supply lower than ~ 170V	●▲●▲●▲●▲●▲
Lockout	▲▲▲▲▲▲▲▲▲▲
Extraneous light	▲□▲□▲□▲□▲□
Key to layout: ○ Off ● Yellow □ Green ▲ Red	

RESETTING THE CONTROL BOX AND USING DIAGNOSTICS

The control box features a diagnostics function through which any causes of malfunctioning are easily identified (indicator: **RED LED**). To use this function, you must wait at least 10 seconds once it has entered the safety condition (**lockout**), and then press the reset button.

The control box generates a sequence of pulses (1 second apart), which is repeated at constant 3-second intervals. Once you have seen how many times the light pulses and identified the possible cause, the system must be reset by holding the button down for between 1 and 3 seconds.

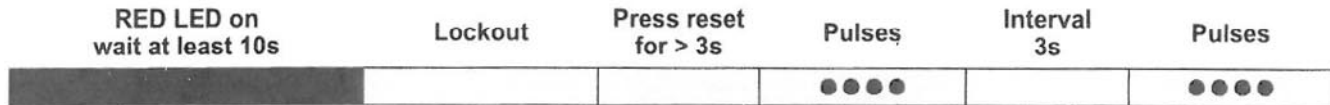

The methods that can be used to reset the control box and use diagnostics are given below.

RESETTING THE CONTROL BOX

To reset the control box, proceed as follows:

- Hold the button down for between 1 and 3 seconds.
The burner restarts after a 2-second pause once the button is released.
If the burner does not restart, you must make sure the limit thermostat is closed.

VISUAL DIAGNOSTICS

Indicates the type of burner malfunction causing lockout.

To view diagnostics, proceed as follows:

- Hold the button down for more than 3 seconds once the red LED (burner lockout) remains steadily lit.
A yellow light pulses to tell you the operation is done.
Release the button once the light pulses. The number of times it pulses tells you the cause of the malfunction, according to the coding system indicated in the table on page 10.

SOFTWARE DIAGNOSTICS

Reports burner life by means of an optical link with the PC, indicating hours of operation, number and type of lockouts, serial number of control box etc ...

To view diagnostics, proceed as follows:

- Hold the button down for more than 3 seconds once the red LED (burner lockout) remains steadily lit.
A yellow light pulses to tell you the operation is done.
Release the button for 1 second and then press again for over 3 seconds until the yellow light pulses again.
Once the button is released, the red LED will flash intermittently with a higher frequency: only now can the optical link be activated.

Once the operations are done, the control box's initial state must be restored using the resetting procedure described above.

BUTTON PRESSED FOR	CONTROL BOX STATUS
Between 1 and 3 seconds	Control box reset without viewing visual diagnostics.
More than 3 seconds	Visual diagnostics of lockout condition: (LED pulses at 1-second intervals).
More than 3 seconds starting from the visual diagnostics condition	Software diagnostics by means of optical interface and PC (hours of operation, malfunctions etc. can be viewed)

The sequence of pulses issued by the control box identifies the possible types of malfunction, which are listed in the table below.

Signal	Problem	Possible cause	Recommended remedy
2 blinks ● ●	Once the pre-purging phase and safety time have passed, the burner goes into lockout without the appearance of the flame	The operation solenoid lets little gas through	Increase
		One of the two solenoid valves does not open.	Replace
		Gas pressure too low	Increase pressure at governor
		Ignition electrode incorrectly adjusted	Adjust
		Electrode grounded due to broken insulation	Replace
		High voltage cable defective	Replace
		High voltage cable deformed by high temperature	Replace and protect
		Ignition transformer defective	Replace
		Incorrect valve or transformer electrical wiring	Check
		Defective control box	Replace
		A closed valve upline the gas train	Open
		Air in pipework	Bleed air
		Gas valves unconnected or with interrupted coil	Check connections or replace coil
3 blinks ● ● ●	The burner does not switch on, and the lockout appears	Air pressure switch in operating position	Adjust or replace
		- Air pressure switch inoperative due to insufficient air pressure:	
	The burner switches on, but then stops in lockout	Air pressure switch incorrectly adjusted.	Adjust or replace
		Pressure switch pressure test point pipe blocked	Clean
		Poorly adjusted head	Adjust
		High pressure in the furnace	Connect air pressure switch to fan suction line
	Lockout during pre-purging phase	Defective motor control contactor (only three-phase version)	Replace
		Defective electrical motor	Replace
Motor lockout (defective electrical motor)		Replace	

Signal	Problem	Possible cause	Recommended remedy
4 blinks ● ● ● ●	The burner switches on, but then stops in lockout	Flame simulation	Replace the control box
	Lockout when burner stops	Permanent flame in the combustion head or flame simulation	Eliminate persistence of flame or replace control box
6 blinks ● ● ● ● ● ●	The burner switches on, but then stops in lockout	Defective or incorrectly adjusted servomotor	Adjust or replace
7 blinks ● ● ● ● ● ● ●	The burner goes into lockout immediately following the appearance of the flame	The operation solenoid lets little gas through	Increase
		Ionisation probe incorrectly adjusted	Adjust
		Insufficient ionisation (less than 5 A)	Check probe position
		Earth probe	Withdraw or replace cable
		Burner poorly grounded	Check grounding
		Phase and neutral connections inverted	Invert them
	Defective flame detection circuit	Replace the control box	
	Burner lockout moving between 1st and 2nd stages, or between 2nd and 1st stages	Too much air or too little gas	Adjust air and gas
Burner goes into lockout during operation	Probe or ionisation cable grounded	Replace worn parts	
10 blinks ● ● ● ● ● ● ● ● ● ●	The burner does not switch on, and the lockout appears	Incorrect electrical wiring	Check
	The burner goes into lockout	Defective control box	Replace
		Presence of electromagnetic disturbances in the thermostat lines Presence of electromagnetic disturbance	Filter or eliminate Use the radio disturbance protection kit
No blink	The burner does not start	No electrical power supply	Close all switches - Check connections
		A limiter or safety control device is open	Adjust or replace
		Line fuse blocked	Replace
		Defective control box	Replace
		No gas supply	Open the manual valves between contactor and train
		Mains gas pressure insufficient	Contact your GAS COMPANY
		Minimum gas pressure switch fails to close	Adjust or replace
Servomotor fails to move to min. ignition position	Replace		

Signal	Problem	Possible cause	Recommended remedy
No blink	The burner continues to repeat the start-up cycle, without lockout	The gas pressure in the gas mains lies very close to the value to which the minimum gas pressure switch has been set. The sudden drop in pressure after valve opening causes temporary opening of the pressure switch itself, the valve immediately closes and the burner comes to a halt. Pressure increases again, the pressure switch closes again and the ignition cycle is repeated. And so on	Reduce the minimum gas pressure switch intervention pressure. Replace the gas filter cartridge.
	Ignition with pulsations	Poorly adjusted head	Adjust
		Ignition electrode incorrectly adjusted	Adjust
		Incorrectly adjusted fan air damper: too much air	Adjust
		Output during ignition phase is too high	Reduce
	The burner does not move into the 2nd stage	Remote control device TR fails to close	Adjust or replace
		Defective control box	Replace
		Defective servomotor	Replace
	Burner stops with air damper open	Defective servomotor	Replace

NORMAL OPERATION / FLAME DETECTION TIME

The control box has a further function to guarantee the correct burner operation (signal: **GREEN LED** permanently on). To use this function, wait at least ten seconds from the burner ignition and then press the control box button for a minimum of 3 seconds. After releasing the button, the GREEN LED starts flashing as shown in the figure below.



The pulses of the LED constitute a signal spaced by approximately 3 seconds. The number of pulses will measure the probe DETECTION TIME since the opening of gas valves, according to the following table:

SIGNAL	FLAME DETECTION TIME
1 blink ●	0.4s
2 blinks ● ●	0.8s
6 blinks ● ● ● ● ● ●	2.8s

This is updated in every burner start-up. Once read, the burner repeats the start-up cycle by briefly pressing the control box button.
WARNING
If the result is > 2s, ignition will be retarded. Check the adjustment of the hydraulic brake of the gas valve, the air damper and the combustion head adjustment.

OWNER INFORMATION AND ROUTINE MAINTENANCE

SAFETY LOCKOUT

This burner is equipped with multiple interlocking safety devices. In the event of a failure in the flame, or any blockage of the combustion air supply, the burner will "lock out" in a safety condition. In such an event, an illuminated red button will show on the front of the red cover.

To restart the burner, press the button once only. Should the burner return to the lock out condition, call a qualified service technician or your gas company for assistance. In the case of loss of pressure in the gas supply line, the burner will go off on safety. If supplied with an optional gas pressure switch (or field installed), the burner will simply switch off on low gas pressure, and start up again when the gas pressure returns to normal.

NOTE: Keep the area around the burner free and clear of all combustible materials, gasoline and other flammable vapours and liquids. Do not allow any obstructions, which may prevent the free, flow of air to the burner.

MAINTENANCE

Like all precision equipment, your burner will require periodic maintenance. At an interval of 2 months, you should:

- 1) If your boiler/furnace has an observation port, visually check the flame.
- 2) Check and clean the air intake louver to remove any buildup of fluff, dust, pet hair, etc.

For any maintenance or repairs over and above those listed, contact your service technician or gas company. **THERE ARE NO OWNER SERVICEABLE PARTS INSIDE THE BURNER COVER.**

Once a year, you should have the burner checked as indicated below, by your local authorized Riello dealer.

- 1) Check burner distributor head and mixing plates. Clean if necessary.
- 2) Check ignition electrode. Clean, adjust, or replace as necessary.
- 3) Check the flame sensor rod (ionization rod) for dirt or carbon build up. Clean, adjust, or replace as necessary.
- 4) Check manifold gas pressure.
- 5) Check all burner adjustments.
- 6) Generally clean all exposed parts and components.
- 7) Repeat combustion tests.

Your Riello 40 gas burner is only part of your heating system.

Once every year you should have your heating appliance serviced by a qualified service technician.

You should also have the chimney checked, and cleaned if necessary.

APPENDIX - SPARE PARTS

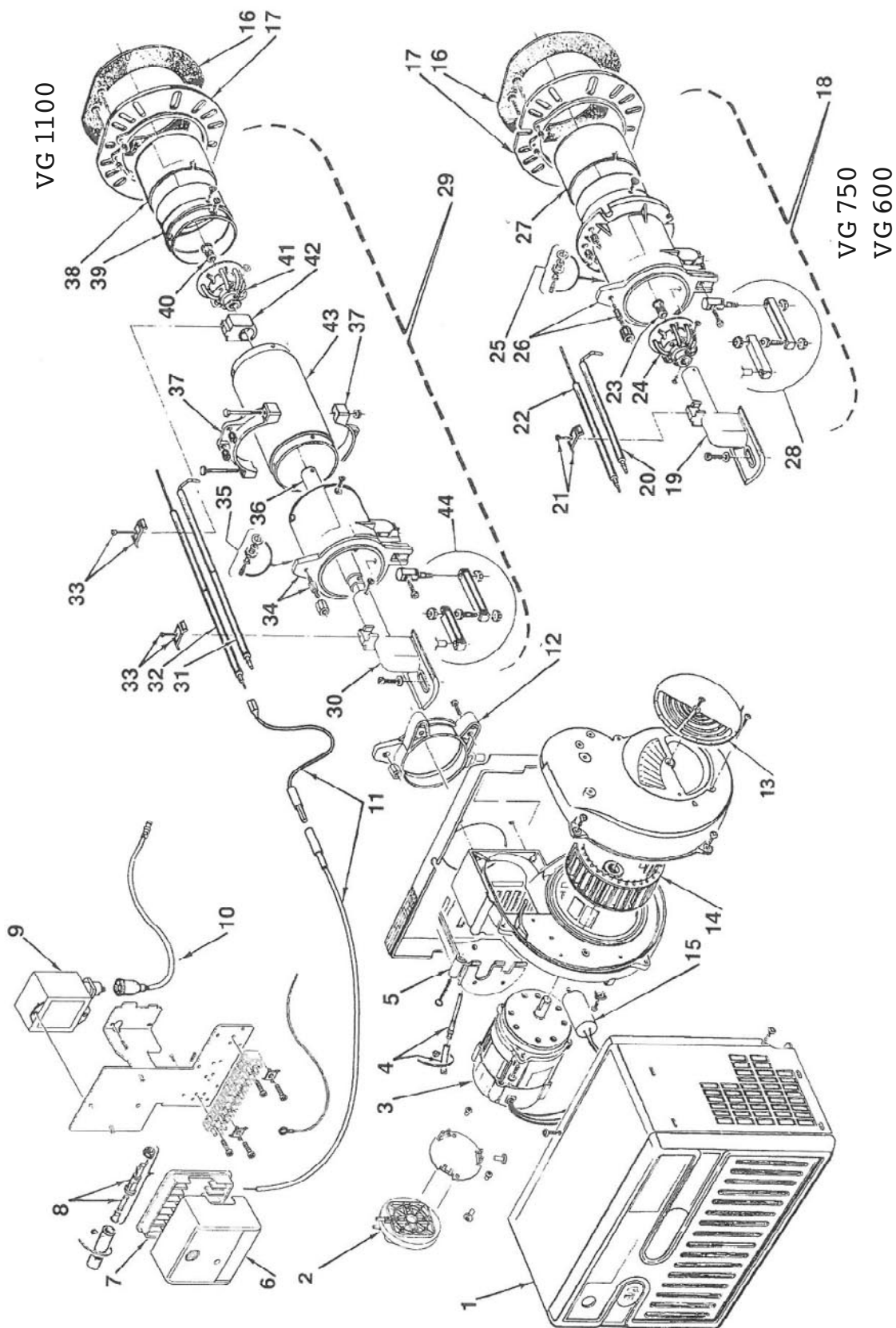

N.	CODE	DESCRIPTION
1	3007246	BURNER BACK COVER
2	3020314	AIR PRESSURE SWITCH
3	3005845	BURNER MOTOR
4	3007288	AIR SWITCH TUBE AND CONNECTOR
5	3007294	AIR PLATE COVER
6	3013072	PRIMARY CONTROL BOX
7	3003784	PRIMARY CONTROL SUB-BASE
8	3006804	FUSE 6.25A
9	3002462	TRANSFORMER - IGNITION
10	3002461	HIGH VOLTAGE LEAD
11	3007310	IONIZATION LEAD
12	3006689	CHASSIS MOUNTING COLLAR
13	3007206	AIR GATE
14	3005799	FAN
15	20087033	CAPACITOR 20 μ F
16	3005852	MOUNTING GASKET
17	3005851	UNIVERSAL MOUNTING FLANGE
18	3950471	SHORT COMBUSTION HEAD (280T1)
19	3006697	DRAWER ASSEMBLY ELBOW
20	3006706	ELECTRODE ASSEMBLY
21	3003409	ELECTRODE & IONIZATION CLAMP
22	3020209	IONIZATION ASSEMBLY
23	3006703	NATURAL GAS DIAPHRAGM
24	3006700	DISTRIBUTOR HEAD AND MIXING PLATE
25	3005447	GAS TEST POINT
26	3007525	MANIFOLD
27	3006694	END CONE
28	3000870	HINGE ASSEMBLY
29	3950472	LONG COMBUSTION HEAD (280T2)
30	3006697	DRAWER ASSEMBLY ELBOW
31	3006962	ELECTRODE ASSEMBLY
32	3020210	IONIZATION ASSEMBLY
33	3003409	ELECTRODE & IONIZATION CLAMP
34	3007526	MANIFOLD
35	3005447	GAS TEST POINT
36	3007313	NATURAL GAS TUBE
37	3005849	SEMI FLANGE 2 REQUIRED
38	3006694	END CONE
39	3007283	COMBUSTION HEAD CONNECTOR
40	3006703	NATURAL GAS DIAPHRAGM
41	3006700	DISTRIBUTOR HEAD AND MIXING PLATE
42	3007314	ELECTRODE SUPPORT
43	3007286	AIR TUBE-LONG
44	3000870	HINGE ASSEMBLY

BURNER DIMENSIONS

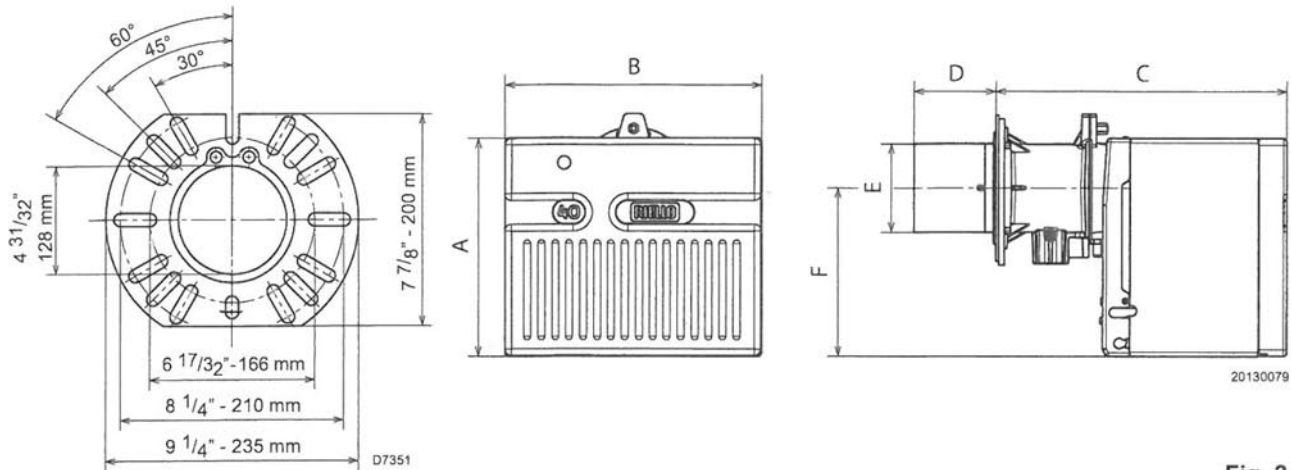

Fig. 2

Model	A	B	C	D	E	F
inches	11 ⁴⁷ / ₆₄	13 ²⁵ / ₃₂	15 ⁴⁵ / ₆₄	4 ¹³ / ₃₂	4 ⁶⁹ / ₆₄	9 ¹ / ₁₆
mm	298	350	399	112	121	230

NOTE: actual available insertion length must be measured from tip of end cone to face of mounting gasket.

ELECTRODE AND FLAME PROBE ADJUSTMENTS

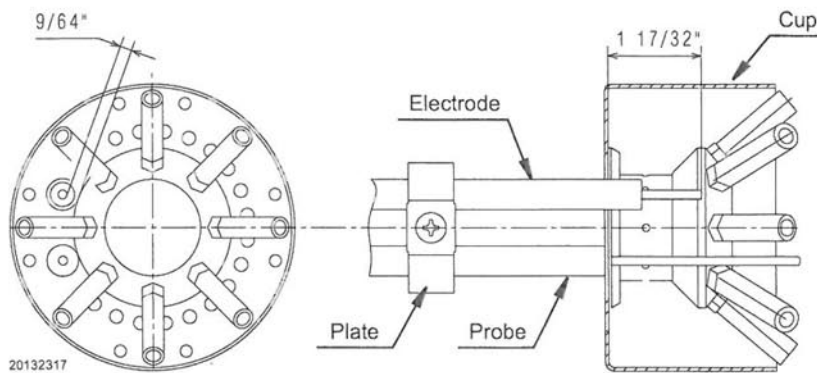

Fig. 3



Lean the probe insulator against the cup.



Do not turn the ignition electrode. Leave it as shown in the drawing.
If the ignition electrode is put near the ionization probe, the amplifier of the control box may be damaged.

INSTALLING THE BURNER

- A) Burner chassis
- B) Combustion head assembly
- 1) Locking nut
- 2) Mounting plate surface
- 3) Insulation gasket

Separate the combustion head of the burner from the chassis (A)(Fig. 4) by removing the locknut (1). Install the combustion head into the boiler.

Typical insertion depth, the front edge of the combustion head is flush with the inside surface of the appliance mounting surface (2).

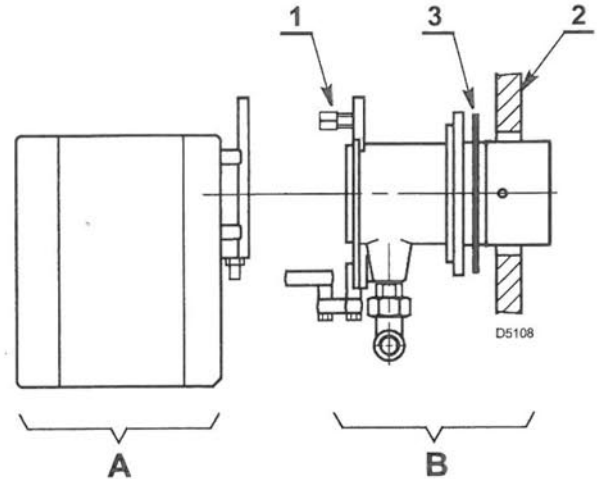

Fig. 4

Use this checklist prior to installation:

- 1) Check the input/output requirements of the boiler/furnace.
- 2) Check the physical size of the combustion chamber against the thermal requirements of the application and relate this to the sizing charts.
- 3) Check that there is sufficient air for proper combustion and adequate ventilation. Local codes should be followed. Check that you have adequate space for servicing the equipment. Riello Burner requires a minimum of 13 inches clear space behind the red cover. This is required to allow easy removal of the cover for servicing and periodic maintenance.
- 4) Check that the chimney is of sufficient area to handle the exhaust gases. Make sure that the chimney is clear and there are not obstructions. Barometric draft regulators, when used, should be of the double acting type, and must be installed in accordance with the draft regulator Manufacturer's instructions. Single acting barometric dampers are not permitted.
- 5) Affix the supplied operating instructions label to the burner. This label reads as follows:

TO START THE BURNER:

Switch on power, open manual gas cocks, set the thermostat above ambient temperature. If the burner does not start, press the illuminated re-set button on the burner safety control.

TO SHUT DOWN BURNER:

Switch off power supply. If burner is switched off for extended periods, close manual gas cocks.



A vent shutoff system shall be applied to a barometric damper installed in the venting system at the time of conversion of the appliance.

This will electrically disconnect the burner should there be a blockage in the vent (chimney).

The installer must identify the main electrical power switch and manual gas shut off valve, for emergency conditions. The burner cover must be in place and secured before the burner is placed in operation.

WIRING DIAGRAM

CONTROL CIRCUITS

Burner operation may be controlled by either 120V or 24V control systems. The required controls must be connected to the burner as described on the following.

120V CONTROL SYSTEM

The burner provides its own power supply for the control circuits that is switched internal from terminal 1)(X12)(L) & 2)(X12)(N), do not apply power on any other terminal or damaged to the control could occur.

24V CONTROL SYSTEM

If firing is to be controlled by a 24V operating system a 24V switching relay wired as shown in the diagram is required (not supplied – sold separately).

The required 24V operating controls must be wired between the thermostat terminals on the 24V-switching relay.

NOTE

If an external electrical source is utilized, the conversion burner, when installed, must be electrically grounded with a solid green wire to Earth Ground, in accordance with local codes or, in the absence of local codes, with the National Electrical Code ANSI/NFPA 70-1990 and the CSA Electrical Code.

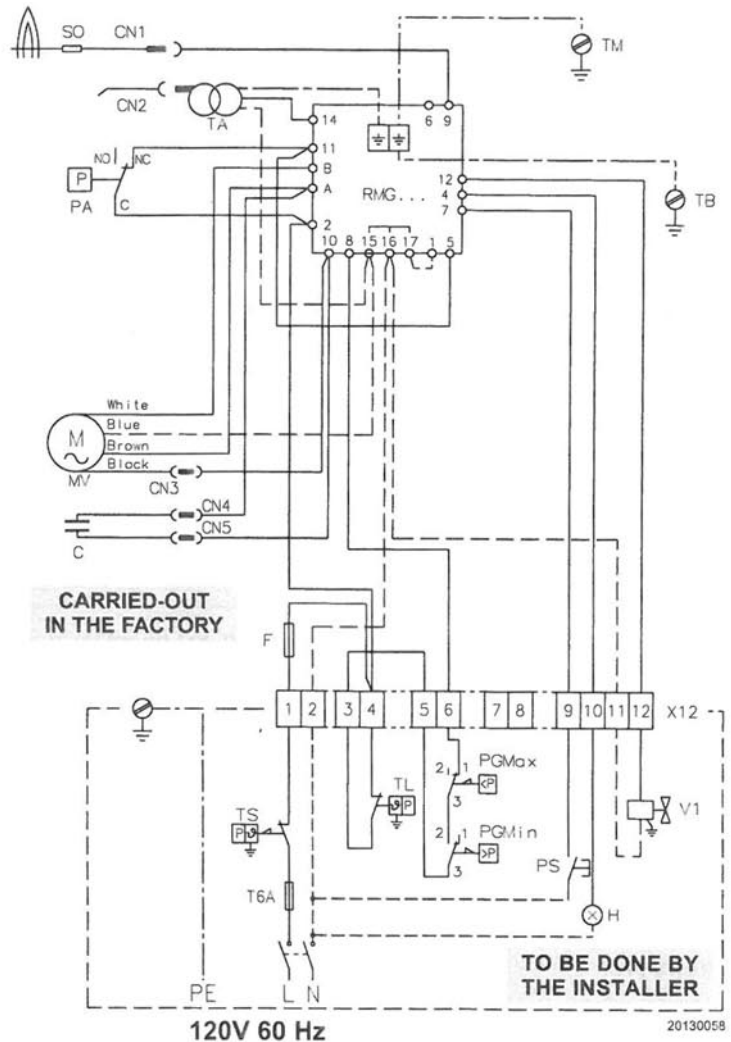

24V CONTROL SYSTEM

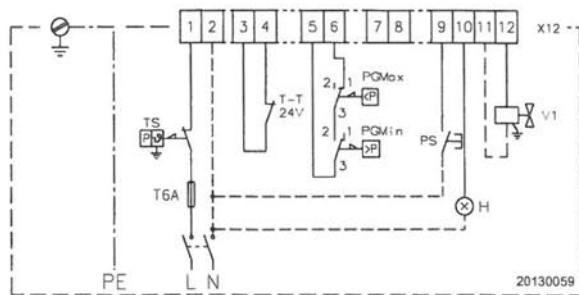

120V CONTROL SYSTEM

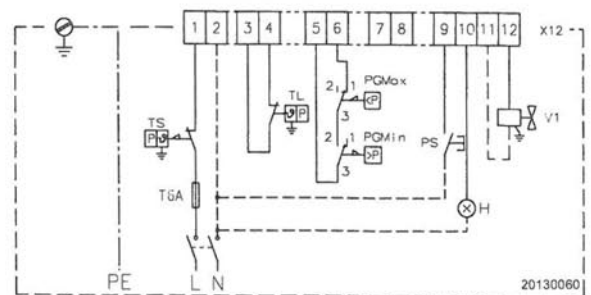

Key

C	Capacitor MV	PGMin	Min gas pressure switch	TM	Earth terminal board
F	Fuse 6.25A	PS	Remote reset push-button	TS	High limit thermostat
CN...	Connectors	RMG...	Control box	T-T	24V operating relay contact
MV	Fan motor	SO	Ionization probe	T6A	Fuse
PA	Air pressure switch	TA	Ignition transformer	V1	Gas valve
PGMax	Max gas pressure switch	TB	Burner earth	X12	Terminal board 12 pole
		TL	Operating thermostat		

RIELLO

COMBUSTION HEAD SETTING

To set combustion head, loosen the Allen screw (A) and move the elbow (B) so that the rear edge of the air tube (C) coincides with the set point number.

See firing rate chart for set points.

Retighten the Allen screw (A).

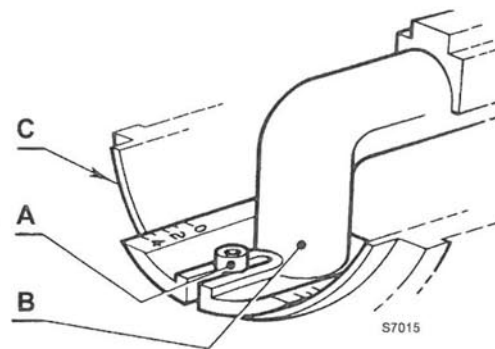

Fig. 5

BURNER SETUP CHART

BTU Input	Air Gate	Stop Gate	Manifold Pressure	Line Pressure
1,000,000	MAX	4.0	2.9" w.c.	12" w.c.

Line pressure measured at gas valve with burner firing.

NOTE:

The above settings are a starting point for adjustments ONLY; a qualified gas technician using proper test equipment must do the final adjustments.

Proper CO₂, O₂, and CO readings must be taken and be within regulating code requirements.

All the settings above are based on zero (0) over fire-draft.

If positive or negative chamber conditions exist some settings changes made be required.

For any referral to valve setting, please check the attached manufacturer valve specification.

AIR GATE ADJUSTMENT

To regulate the combustion air, adjust the manual air gate (3)(Fig. 6), by loosening the locking screws (4).

Once the optimal adjustment is reached, tighten the locking screws (4).

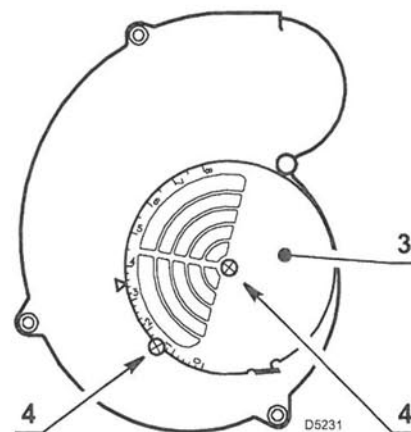

Fig. 6

COMBUSTION CHECKS

CO₂ It is advisable not to exceed a measured reading of 10% CO₂ for Natural Gas or 12% CO₂ for Propane Gas taken with the burner cover in place, to avoid the risk of the formation of CO due to minor changes in wind/draft conditions which may occur.

CO For safety reasons, the value of .02% (200ppm) free air sample must not be exceeded.

IONIZATION CURRENT

The minimum amount of current necessary for the control box to operate properly is 5 micro Amps DC.

To measure the ionization current, disconnect the red wire connector and insert a DC micrometer in series with control box terminal 9 and the ionization probe, which senses the flame.

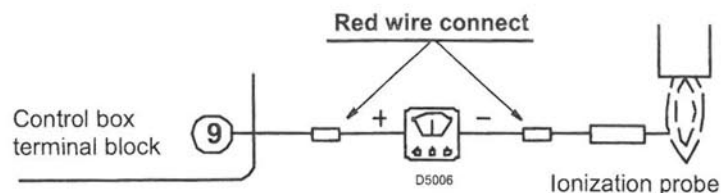

Fig. 7

BURNER START-UP CYCLE

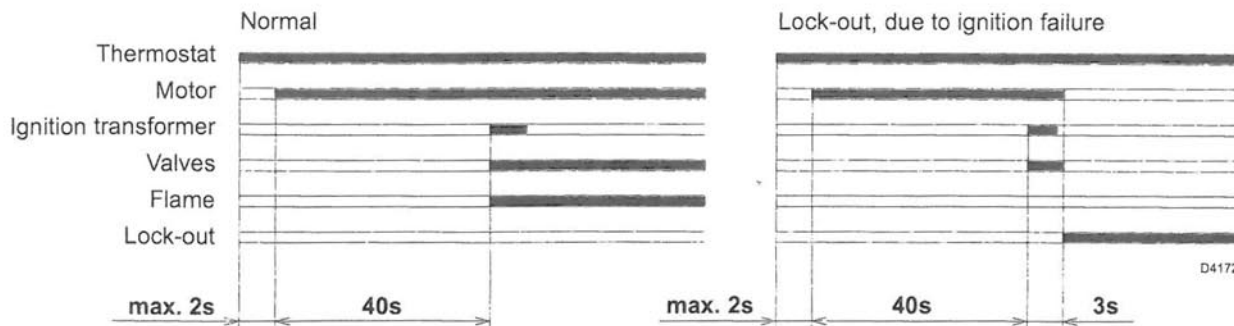

Fig. 8

START-UP CYCLE DIAGNOSTICS

During start-up, indication is according to the following table:

COLOUR CODE TABLE	
Sequences	Colour code
Pre-purging	●●●●●●●●●●
Firing phase	●○●○●○●○●○
Operation, flame ok	□□□□□□□□
Operating with weak flame signal	□○□○□○□○□○
Electrical supply lower than ~ 170V	●▲●▲●▲●▲●▲●
Lockout	▲▲▲▲▲▲▲▲▲▲
Extraneous light	▲□▲□▲□▲□▲□
Key to layout: ○ Off ● Yellow □ Green ▲ Red	

RESETTING THE CONTROL BOX AND USING DIAGNOSTICS

The control box features a diagnostics function through which any causes of malfunctioning are easily identified (indicator: **RED LED**). To use this function, you must wait at least 10 seconds once it has entered the safety condition (**lockout**), and then press the reset button.

The control box generates a sequence of pulses (1 second apart), which is repeated at constant 3-second intervals. Once you have seen how many times the light pulses and identified the possible cause, the system must be reset by holding the button down for between 1 and 3 seconds.

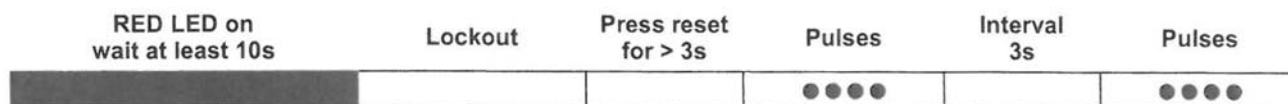

The methods that can be used to reset the control box and use diagnostics are given below.

RESETTING THE CONTROL BOX

To reset the control box, proceed as follows:

- Hold the button down for between 1 and 3 seconds.
The burner restarts after a 2-second pause once the button is released.
- If the burner does not restart, you must make sure the limit thermostat is closed.

VISUAL DIAGNOSTICS

Indicates the type of burner malfunction causing lockout.

To view diagnostics, proceed as follows:

- Hold the button down for more than 3 seconds once the red LED (burner lockout) remains steadily lit.

A yellow light pulses to tell you the operation is done.

Release the button once the light pulses. The number of times it pulses tells you the cause of the malfunction, according to the coding system indicated in the table on page 10.

SOFTWARE DIAGNOSTICS

Reports burner life by means of an optical link with the PC, indicating hours of operation, number and type of lockouts, serial number of control box etc ...

To view diagnostics, proceed as follows:

- Hold the button down for more than 3 seconds once the red LED (burner lockout) remains steadily lit.

A yellow light pulses to tell you the operation is done.

Release the button for 1 second and then press again for over 3 seconds until the yellow light pulses again.

Once the button is released, the red LED will flash intermittently with a higher frequency: only now can the optical link be activated.

Once the operations are done, the control box's initial state must be restored using the resetting procedure described above.

BUTTON PRESSED FOR	CONTROL BOX STATUS
Between 1 and 3 seconds	Control box reset without viewing visual diagnostics.
More than 3 seconds	Visual diagnostics of lockout condition: (LED pulses at 1-second intervals).
More than 3 seconds starting from the visual diagnostics condition	Software diagnostics by means of optical interface and PC (hours of operation, malfunctions etc. can be viewed)

The sequence of pulses issued by the control box identifies the possible types of malfunction, which are listed in the table below.

Signal	Problem	Possible cause	Recommended remedy
2 blinks ● ●	Once the pre-purging phase and safety time have passed, the burner goes into lockout without the appearance of the flame	The operation solenoid lets little gas through	Increase
		One of the two solenoid valves does not open.	Replace
		Gas pressure too low	Increase pressure at governor
		Ignition electrode incorrectly adjusted	Adjust
		Electrode grounded due to broken insulation	Replace
		High voltage cable defective	Replace
		High voltage cable deformed by high temperature	Replace and protect
		Ignition transformer defective	Replace
		Incorrect valve or transformer electrical wiring	Check
		Defective control box	Replace
		A closed valve upline the gas train	Open
		Air in pipework	Bleed air
		Gas valves unconnected or with interrupted coil	Check connections or replace coil
3 blinks ● ● ●	The burner does not switch on, and the lockout appears	Air pressure switch in operating position	Adjust or replace
	The burner switches on, but then stops in lockout	- Air pressure switch inoperative due to insufficient air pressure:	
		Air pressure switch incorrectly adjusted.	Adjust or replace
		Pressure switch pressure test point pipe blocked	Clean
		Poorly adjusted head	Adjust
	Lockout during pre-purging phase	Defective motor control contactor (only three-phase version)	Replace
		Defective electrical motor	Replace
Motor lockout (defective electrical motor)		Replace	
4 blinks ● ● ● ●	The burner switches on, but then stops in lockout	Flame simulation	Replace the control box
	Lockout when burner stops	Permanent flame in the combustion head or flame simulation	Eliminate persistence of flame or replace control box
6 blinks ● ● ● ● ● ●	The burner switches on, but then stops in lockout	Defective or incorrectly adjusted servomotor	Adjust or replace
7 blinks ● ● ● ● ● ● ●	The burner goes into lockout immediately following the appearance of the flame	The operation solenoid lets little gas through	Increase
		Ionisation probe incorrectly adjusted	Adjust
		Insufficient ionisation (less than 5 A)	Check probe position
		Earth probe	Withdraw or replace cable
		Burner poorly grounded	Check grounding
		Phase and neutral connections inverted	Invert them
	Defective flame detection circuit	Replace the control box	
Burner lockout moving between 1st and 2nd stages, or between 2nd and 1st stages	Too much air or too little gas	Adjust air and gas	
Burner goes into lockout during operation	Probe or ionisation cable grounded	Replace worn parts	
10 blinks ● ● ● ● ● ● ● ● ● ●	The burner does not switch on, and the lockout appears	Incorrect electrical wiring	Check
	The burner goes into lockout	Defective control box	Replace
		Presence of electromagnetic disturbances in the thermostat lines Presence of electromagnetic disturbance	Filter or eliminate Use the radio disturbance protection kit

Signal	Problem	Possible cause	Recommended remedy
No blink	The burner does not start	No electrical power supply	Close all switches - Check connections
		A limiter or safety control device is open	Adjust or replace
		Line fuse blocked	Replace
		Defective control box	Replace
		No gas supply	Open the manual valves between contactor and train
		Mains gas pressure insufficient	Contact your GAS COMPANY
		Minimum gas pressure switch fails to close	Adjust or replace
No blink	The burner continues to repeat the start-up cycle, without lockout	The gas pressure in the gas mains lies very close to the value to which the minimum gas pressure switch has been set. The sudden drop in pressure after valve opening causes temporary opening of the pressure switch itself, the valve immediately closes and the burner comes to a halt. Pressure increases again, the pressure switch closes again and the ignition cycle is repeated. And so on	Reduce the minimum gas pressure switch intervention pressure. Replace the gas filter cartridge.
		Ignition with pulsations	Poorly adjusted head Ignition electrode incorrectly adjusted Incorrectly adjusted fan air damper: too much air Output during ignition phase is too high
	The burner does not move into the 2nd stage	Remote control device TR fails to close	Adjust or replace
		Defective control box	Replace
	Burner stops with air damper open	Defective servomotor	Replace
		Defective servomotor	Replace

NORMAL OPERATION / FLAME DETECTION TIME

The control box has a further function to guarantee the correct burner operation (signal: **GREEN LED** permanently on). To use this function, wait at least ten seconds from the burner ignition and then press the control box button for a minimum of 3 seconds. After releasing the button, the GREEN LED starts flashing as shown in the figure below.

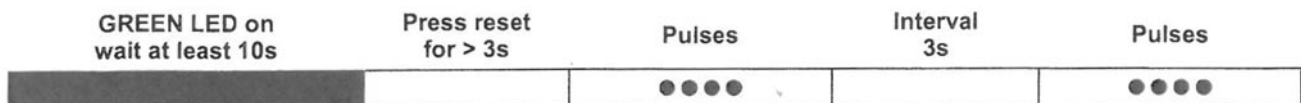

The pulses of the LED constitute a signal spaced by approximately 3 seconds. The number of pulses will measure the probe DETECTION TIME since the opening of gas valves, according to the following table:

SIGNAL	FLAME DETECTION TIME
1 blink ●	0.4s
2 blinks ● ●	0.8s
6 blinks ● ● ● ● ● ●	2.8s

This is updated in every burner start-up. Once read, the burner repeats the start-up cycle by briefly pressing the control box button.

WARNING

If the result is > 2s, ignition will be retarded. Check the adjustment of the hydraulic brake of the gas valve, the air damper and the combustion head adjustment.

OWNER INFORMATION AND ROUTINE MAINTENANCE**SAFETY LOCKOUT**

This burner is equipped with multiple interlocking safety devices. In the event of a failure in the flame, or any blockage of the combustion air supply, the burner will "lock out" in a safety condition. In such an event, an illuminated red button will show on the front of the red cover.

To restart the burner, press the button once only. Should the burner return to the lock out condition, call a qualified service technician or your gas company for assistance. In the case of loss of pressure in the gas supply line, the burner will go off on safety. If supplied with an optional gas pressure switch (or field installed), the burner will simply switch off on low gas pressure, and start up again when the gas pressure returns to normal.

NOTE: Keep the area around the burner free and clear of all combustible materials, gasoline and other flammable vapours and liquids. Do not allow any obstructions, which may prevent the free, flow of air to the burner.

MAINTENANCE

Like all precision equipment, your burner will require periodic maintenance. At an interval of 2 months, you should:

- 1) If your boiler/furnace has an observation port, visually check the flame.
- 2) Check and clean the air intake louver to remove any buildup of fluff, dust, pet hair, etc.

For any maintenance or repairs over and above those listed, contact your service technician or gas company.

THERE ARE NO OWNER SERVICEABLE PARTS INSIDE THE BURNER COVER.

Once a year, you should have the burner checked as indicated below, by your local authorized Riello dealer.

- 1) Check that the holes of the gas head are not obstructed. If they are, clean them with a suitable tool as shown in the figure 9.
- 2) Check ignition electrode. Clean, adjust, or replace as necessary.
- 3) Check the flame sensor rod (ionization rod) for dirt or carbon build up.

Clean, adjust, or replace as necessary.

- 4) Check manifold gas pressure.
- 5) Check all burner adjustments.
- 6) Generally clean all exposed parts and components.
- 7) Repeat combustion tests.

Your Riello 40 gas burner is only part of your heating system.

Once every year you should have your heating appliance serviced by a qualified service technician.

You should also have the chimney checked, and cleaned if necessary.

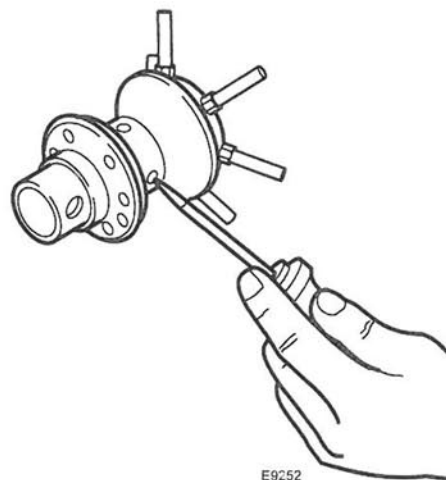

E9252

Fig. 9

APPENDIX - SPARE PARTS

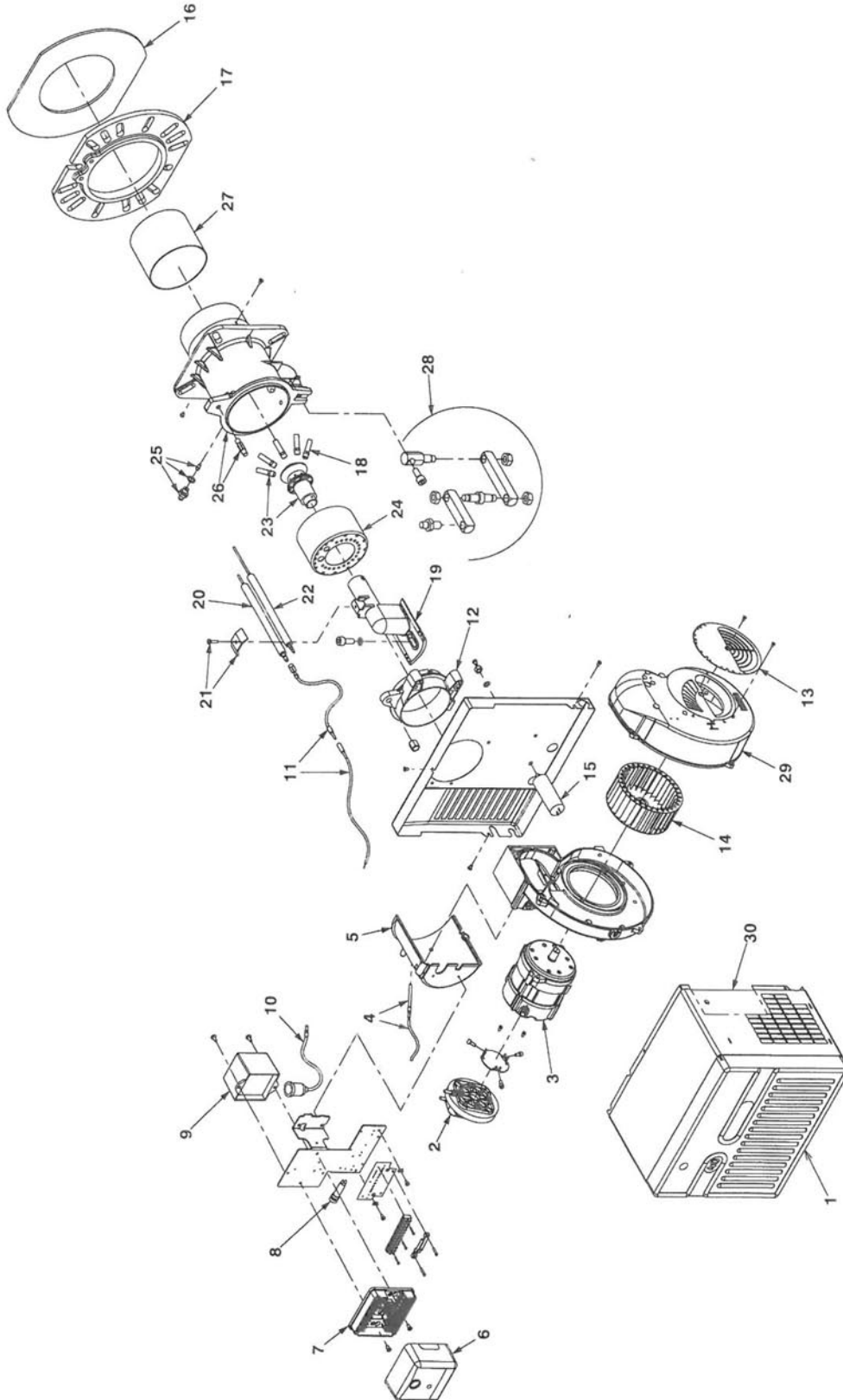

RIELLO

N.	CODE	DESCRIPTION
1	3007246	BURNER BACK COVER
2	3020314	AIR PRESSURE SWITCH
3	20091753	BURNER MOTOR
4	3007288	AIR SWITCH TUBE AND CONNECTOR
5	3007294	AIR PLATE COVER
6	3013072	PRIMARY CONTROL BOX
7	3003784	PRIMARY CONTROL SUB-BASE
8	3006804	FUSE 6.25A
9	3002462	TRANSFORMER - IGNITION
10	3002461	HIGH VOLTAGE LEAD
11	3007310	IONIZATION LEAD
12	3006689	CHASSIS MOUNTING COLLAR
13	3007206	AIR GATE
14	3005799	FAN
15	20087033	CAPACITOR 20 μ F
16	3005852	MOUNTING GASKET
17	3005851	UNIVERSAL MOUNTING FLANGE
18	20035544	GAS PIPE
19	3006697	DRAWER ASSEMBLY ELBOW
20	20130046	ELECTRODE ASSEMBLY
21	3003409	ELECTRODE & IONIZATION CLAMP
22	20130047	IONIZATION ASSEMBLY
23	3006703	NATURAL GAS DIAPHRAM
24	3008501	DISTRIBUTOR HEAD AND MIXING PLATE
25	3005447	GAS TEST POINT
26	20130045	MANIFOLD
27	3006694	END CONE
28	3000870	HINGE ASSEMBLY
29	3007210	BURNER AIR SETTING
30	3007358	SOUND DAMPING

EXHAUST FLUE PIPE GUIDELINES

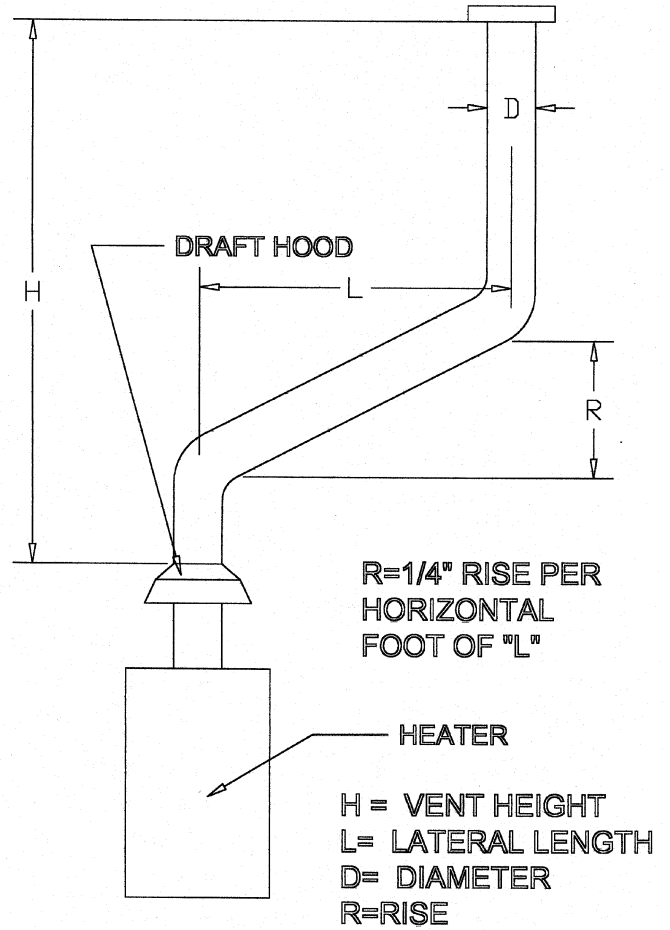
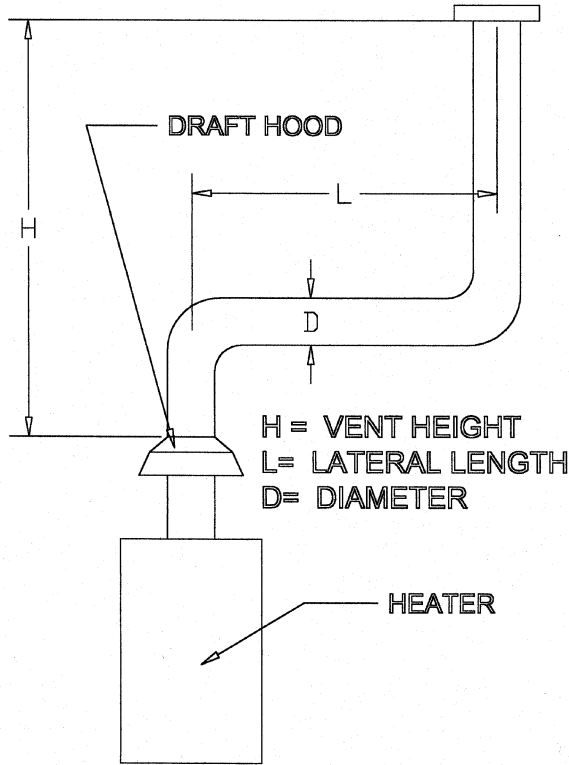

CAPACITY OF TYPE B DOUBLE- WALL VENTS SERVING A SINGLE DRAFT HOOD-HEATER x 1000 BTU'S

FOR INDOOR APPLICATIONS

TOTAL VENT HEIGHT (H) FEET	LATERAL LENGTH (L) FEET	VENT DIAMETER (D) INCHES							
		10	12	14	16	18	20	22	24
6	0	NR	850	1170	1530	1960	2430	2950	3520
	2	NR	650	890	1170	1480	1850	2220	2670
	6	NR	630	870	1150	1470	1820	2210	2650
	12	NR	610	840	1110	1430	1795	2180	2600
8	0	NR	970	1320	1740	2220	2750	3360	4010
	2	NR	745	1020	1340	1700	2110	2560	3050
	8	NR	720	1000	1320	1670	2070	2530	3030
	16	NR	685	950	1260	1600	2035	2470	2960
10	0	NR	1060	1450	1925	2450	3050	3710	4450
	2	NR	850	1130	1480	1890	2340	2840	3390
	10	NR	795	1080	1430	1840	2280	2780	3340
	20	NR	735	1030	1360	1780	2230	2720	3250
15	0	NR	1240	1720	2270	2900	3620	4410	5300
	2	NR	985	1350	1770	2260	2800	3410	4080
	15	NR	905	1250	1675	2150	2700	3300	3980
	30	NR	845	1180	1550	2050	2620	3210	3840
20	0	NR	1350	1900	2520	3250	4060	4980	6000
	2	NR	1100	1520	2000	2570	3200	3910	4700
	10	NR	1045	1460	1940	2500	3130	3830	4600
	20	NR	990	1390	1880	2430	3050	3760	4550
30	0	NR	945	1270	1700	2330	2980	3650	4390
	2	NR	1550	2170	2920	3770	4750	5850	7060
	2	NR	865	1310	1800	2380	3050	3810	4650
	20	NR	784	1185	1650	2200	2870	3650	4480
	40	NR	705	1075	1520	2060	2700	3480	4270



*342 N. Co. Rd. 400 East
Valparaiso, IN 46383
219-464-8818 • Fax 219-462-7985
www.heatwagon.com*