



342 N. Co. Rd. 400 East
Valparaiso, IN 46383
219-464-8818 • Fax 219-462-7985
www.heatwagon.com

Installation and Maintenance Manual
Please retain this manual for future reference.

HVF110, 210, 310, 410HD

Construction Heaters



HVF110 for SN 21103001 and beyond
HVF210 for SN 21202501 and beyond
HVF310 for SN 21302501 and beyond
HVF410HD for SN 21801001 and beyond

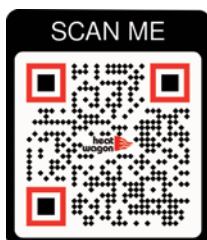

Revision 1-24

For your safety: Do not use this heater in a space where gasoline or other liquids having flammable vapors are stored.

CONSTRUCTION HEATER GENERAL HAZARD WARNING

READ INSTRUCTIONS CAREFULLY. READ AND FOLLOW ALL INSTRUCTIONS. PLACE INSTRUCTIONS IN A SAFE PLACE FOR FUTURE REFERENCE. DO NOT ALLOW ANYONE WHO HAS NOT READ THESE INSTRUCTIONS TO ASSEMBLE, LIGHT, ADJUST OR OPERATE THE HEATER.

IF THE INFORMATION IN THIS MANUAL IS NOT FOLLOWED EXACTLY, A FIRE OR EXPLOSION MAY RESULT CAUSING PROPERTY DAMAGE, PERSONAL INJURY OR LOSS OF LIFE.

SERVICE MUST BE PERFORMED BY A QUALIFIED SERVICE TECHNICIAN.

UNVENTED PORTABLE HEATERS USE AIR (OXYGEN) FROM THE AREA IN WHICH IT IS USED. ADEQUATE COMBUSTION AND VENTILATION AIR MUST BE PROVIDED. REFER TO INSTRUCTIONS.

WARNING

FIRE, BURN, INHALATION, AND EXPLOSION HAZARD.

KEEP SOLID COMBUSTIBLES, SUCH AS BUILDING MATERIALS, PAPER OR CARDBOARD, A SAFE DISTANCE

AWAY FROM THE HEATER AS RECOMMENDED BY THE INSTRUCTIONS. NEVER USE THE HEATER IN SPACES WHICH DO OR MAY CONTAIN VOLATILE OR AIRBORNE COMBUSTIBLES, OR PRODUCTS SUCH AS GASOLINE, SOLVENTS, PAINT THINNER, DUST PARTICLES OR UNKNOWN CHEMICALS.

WARNING

COMBUSTION BY-PRODUCTS PRODUCED WHEN USING THIS PRODUCT CONTAIN CARBON MONOXIDE, A CHEMICAL KNOWN TO THE STATE OF CALIFORNIA TO CAUSE CANCER AND BIRTH DEFECTS (OR OTHER REPRODUCTIVE HARM).

WARNING

NOT FOR HOME OR RECREATIONAL VEHICLE USE

We cannot anticipate every use which may be made for our heaters. CHECK WITH YOUR LOCAL FIRE SAFETY AUTHORITY IF YOU HAVE QUESTIONS ABOUT LOCAL REGULATIONS.

Other standards govern the use of fuel gases and heat producing products in specific applications. Your local authority can advise you about these.

FOR YOUR SAFETY

DO NOT USE THIS HEATER IN A SPACE WHERE GASOLINE OR OTHER LIQUIDS HAVING FLAMMABLE VAPORS ARE STORED OR USED.

IMPORTANT

Heater is designed for use as a construction heater. Heater is not intended for use in pest remediation. The primary purpose of construction heaters is to provide temporary heating of buildings under construction, alteration, or repair and to provide emergency heat. Properly used, the heater provides safe, economical heating. Products of combustion are vented outside the area being heated.

Installation and Maintenance Manual Model HVF110, 210, 310, 410HD Construction Heater

Table of Contents:

Safety and Caution	2
Specifications	4
Installation	5
Operating Instructions	5, 17
Maintenance	5, 18
Control Board	6, 16
Accessories	7
HVF110 Wiring/Parts	8-10
HVF210 Wiring/Parts	11-13
HVF310 Wiring/Parts	11, 14-15
HVF410HD Wiring/Parts	20-23
Chimney/Flue Set-up	19
Troubleshooting	24-30

WARRANTY

All new Heat Wagon and Sure Flame heaters and fans are guaranteed against defective materials and workmanship for one (1) year from invoice date.

Warranty repairs may be made only by an authorized, trained and certified Heat Wagon dealer. Warranty repairs by other entities will not be considered. Warranty claims must include model number and serial number.

LIMITATIONS

Warrant claims for service parts (wear parts) such as spark plugs, igniters, flame rods will not be allowed. Diagnostic parts such as voltage meters and pressure gauges are not warrantable.

Evidence of improper fuel usage, fuel pressures outside of manufacturer's specification, poor fuel quality, and improper electric power, misapplication or evidence of abuse may be cause for rejection of warranty claims.

Travel time, mileage and shipping charges will not be allowed. Minor adjustments of heaters are dealers' responsibility. Defective parts must be tagged and held for possible return to the factory for 60 days from date of repair. The factory will provide a return goods authorization, (RGA) for defective parts to be returned.

No warranty will be allowed for parts not purchased from Heat Wagon.



342 N. Co. Rd. 400 East • Valparaiso, IN 46383
219-464-8818 • 888-432-8924 • Fax 800-255-7985
www.heatwagon.com

TECHNICAL SPECIFICATIONS			HVF110	HVF210	HVF310	HVF410HD
Heat input	[kBTU/h]		112	205	294	412/272
Air flow	[cfm]		1020	1530	2531	3250
Efficiency	[%]		85.0	89.5	88.0	
Heat output	[kBTU/h]		94.8	183.5	258.7	354/231
Fuel consumption	[gal/h]		0.81	1.48	2.17	2.89/1.86
	[lb/h]		5.73	10.47	15.37	
Power supply	Phase		1	1	1	1
	Voltage	[V]	120	120	120	120
	Frequency	[Hz]	60	60	60	60
Electric consumption	[W]		440	785	1,330	1,820
	[A]		4.05	7.65	11.80	20
Nozzle	[USgal/h]		0.55-80° W	1.10-80° W	1.50-80° W	2.0-80° W
Pump pressure	[psi]		196	174	174	160/218
Static pressure	[in WC]		0.5	0.5	0.5	0.6
Adjustment of combustion air flap	[in]		0.118	A=3.5, .196	A=4, .236	1.5
Flue diameter	[in]		5.9	5.9	5.9	5.90
Compulsory flue draft	[in WC]		0.05	0.05	0.05	0.05
Tank capacity	[gal]		17.2	27.7	35.7	57
Dimensions , L x W x H	[in]		49.3x20x33.3	56.5x21.9x38	56.5x21.9x38	83x33x48
Net Weight	[lb]		142	220	297	456

Fuel Blend Guide	
Temperature Range	Fuel Blend
15° to 30°F	80% #2 : 20% #1
0° to 15°F	70% #2 : 30% #1
-15° to 0°F	50% #2 : 50% #1
below -15°F	30% #2 : 70% #1

**Runs on: #2 diesel (winter blend)
#1 kerosene**

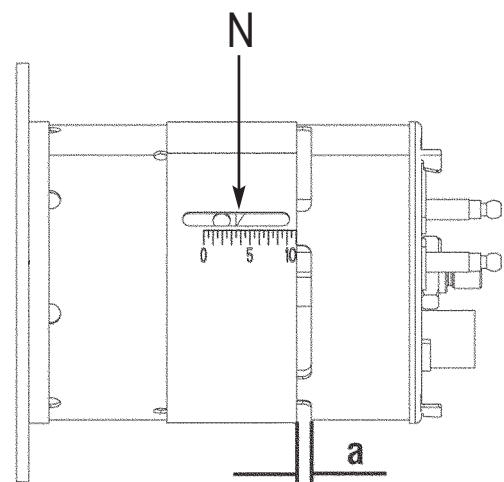

Figure 1

HVF 110, 210, 310

IMPORTANT

Before using the heater, read and understand all instructions and follow them carefully. The manufacturer is not responsible for damages to goods or persons due to improper use of units.

GENERAL RECOMMENDATIONS

The hot air heaters run on heating oil. Those with direct combustion send hot air and the combustion products into the room, while those with indirect combustion are fitted with a flue to take the products of combustion away through the chimney.

Always follow local ordinances and codes when using this heater:

- Read and follow this owner's manual before using the heater;
- THE INSTALLATION OF THE UNIT SHALL BE IN ACCORDANCE WITH THE REGULATIONS OF THE AUTHORITIES HAVING JURISDICTION. Also, as a recommended installation practice reference should be made to the current issue of CSA B139, Installation Code for Oil Burning Equipment in Canada and NFPA 31 Standard for the Installation of Oil-Burning Equipment in the USA.
- Use only in places free of flammable vapours or high dust content;
- Never use heater in immediate proximity of flammable materials (the minimum distance must be 5 ft);
- Make sure fire fighting equipment is readily available;
- Make sure sufficient fresh outside air is provided according to the heater requirements. Direct combustion heaters should only be used in well vented areas in order to avoid carbon monoxide poisoning;
- A rough estimate of opening required for each gallon (US) of capacity is one square foot for indirect-fired heater and three square foot at heater level, for direct-fired heaters;
- the heater is installed near a chimney to vent products of combustion (see the paragraph "CHIMNEY LAY-OUT RECOMMENDATION") and connected to an electrical switchboard;
- When the heater is connected to a flue pipe, the flue pipe shall terminate in a vertical section at least two feet long and sufficient draft shall be created to assure safe and proper operation of the heater;
- Never block air inlet (rear) or air outlet (front);
- In case of very low temperatures add kerosene to the heating oil; -below 20°F
- Before starting the heater always check free rotation of fan;
- Make sure heater is always under surveillance and keep children and animals away from it;
- Connect the power cord to the mains and wait 15 min at least before starting heater, to allow pre-heated filter warming heating oil inside the filter;
- Indirect fired units only can be connected to air ducts to distribute warm air, with respect to the max. static pressure declared (see "TECHNICAL SPECIFICATION" sheet);
- Unplug heater when not in use.

OPERATION

Before any attempt of starting the heater is made, check that your electrical supply conforms to the data on the model plate.

Warning



Mains must be fitted with a breaker switch.

**Unit plug must be linked to a socket with a mains disconnect switch
Do not touch exhaust gas outlet danger of burns.**

The heater can only work automatically when a control device, such as for example a thermostat or a timer, is connected to the generator. Connection to the heater is made by removing the socket cover (4) and inserting the thermostat plug.

To start the machine you must:

- if connected to the thermostat, turn the switch to (ON + );
- if not connected to the thermostat, turn the switch to (ON).

When unit is started for the first time or is started after the oil tank has been totally emptied, the flow of oil to the burner may be impaired by air in the circuit. In this case the control box will cut out the heater and it might be necessary to renew the starting procedure once or twice by depressing the reset button (1).

Hand filling the filter cup with fuel may help to prime the pump.

Should the heater not start, check that oil tank is full and depress reset button (1).

Should the heater still not work, please refer to chapter "OBSERVED FAULTS, CAUSES AND REMEDIES".

STOPPING THE HEATER

Set main switch (3) on "0" position or turn thermostat or other control device on lowest setting.

The flame goes out and the fan continues to work for approx. 90 sec. cooling the combustion chamber.

SAFETY DEVICES

The unit is fitted with an electronic flame control box. In case of malfunction this box will cut in and stop the heater, at the same time the pilot lamp in the control box reset button (1) will light up.

Heaters are also equipped with an overheat thermostat safety cut out which will stop the heater in case of overheating. This thermostat will reset automatically but you will have to depress button (1) on control box before being able to restart the heater.

TRANSPORT

Warning



Before making any attempt to restart heater find and eliminate reason of overheating.

Before heater is moved it must be stopped and unplugged. Before moving the heater wait till it has totally cooled off and make sure oil tank cap is securely fixed.

The hot air heater with wheels must be wheeled. The suspended version which has no wheels must be transported with adequate machinery.

MAINTENANCE

Preventive and regular maintenance will ensure a long trouble free life to your heater.

Warning



Never service heater while it is plugged in, operating or hot. Severe burns or electrical shock can occur.

Every 50 hours of operation: disassemble filter and wash with clean oil, remove upper body parts and clean inside and fan with compressed air, check correct attachment of H.T. connectors to the electrodes and check H.T. cables, remove burner assembly, clean and check electrode settings, adjust according to "REGULATION OF ELECTRODES".

HVF 110, 210, 310 Only

CONTROL BOARD

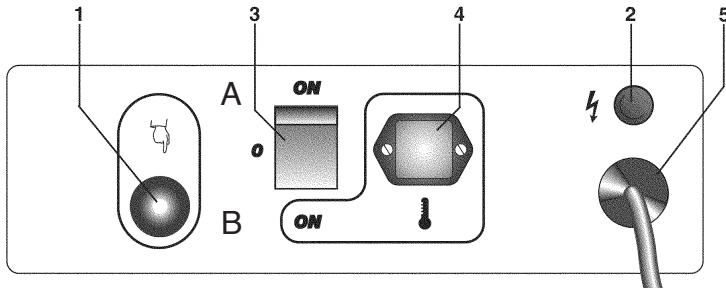

1. Reset Button
2. Control Lamp
3. Main Switch A-No Thermostat
B-With Thermostat
4. Room Thermostat Plug
5. Power Cord

HVF 410 Only

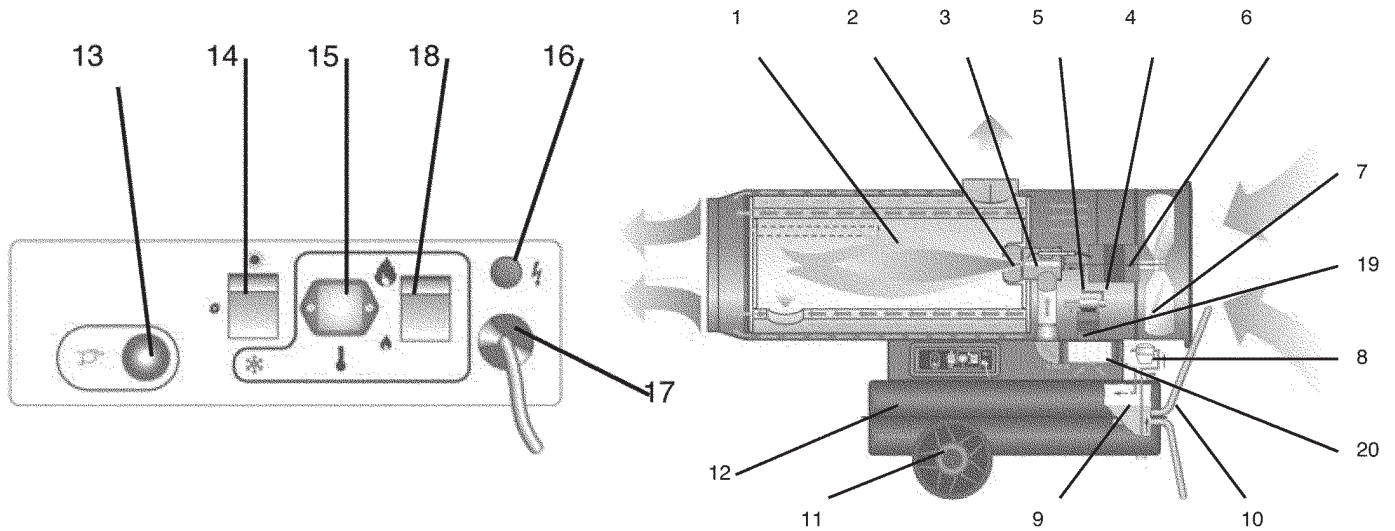

- 1 COMBUSTION CHAMBER
- 2 BURNER
- 3 NOZZLE
- 4 SOLENOID VALVE
- 5 DIESEL PUMP
- 6 COOLING FAN MOTOR
- 7 FAN
- 8 FUEL FILTER
- 9 FUEL CIRCUIT
- 10 SUPPORT/HANDLE

- 11 WHEEL
- 12 FUEL TANK
- 13 RESET BUTTON WITH CONTROL LAMP
- 14 MAIN SWITCH
- 15 ROOM THERMOSTAT PLUG
- 16 CONTROL LAMP
- 17 POWER CORD
- 18 HIGH - LOW THERMAL POWER SWITCH
- 19 BURNER MOTOR
- 20 AIR COMBUSTION ADJUSTMENT

Regulation of Electrodes

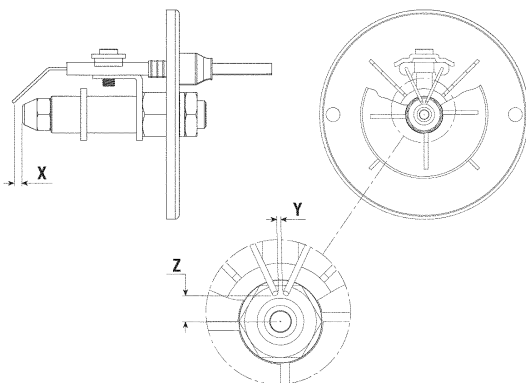

Models	X	Y	Z
HVF110	2 mm	3 mm	6,5 mm
HVF210	4 mm	2,5 mm	4 mm
HVF310	4 mm	2,5 mm	4 mm
HVF410HD	2 mm	3 mm	6,5 mm

Note: 1/16" = 1.6 mm

Accessories



THERMOSTAT
#ACC TH1DF

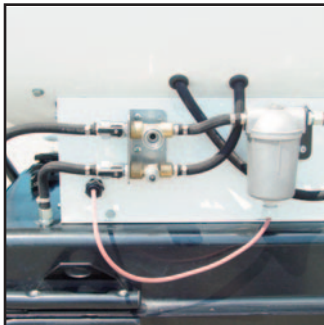

EXTERNAL FUEL KIT
(allows access to external fuel source)
#ACC TK300

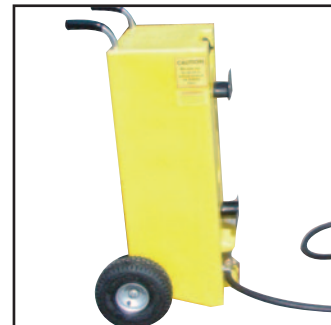

FUEL CADDY (28 GALLONS)
#ACC PFC28

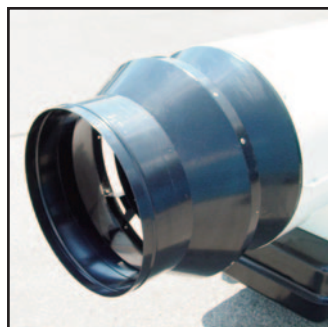

DUCT ADAPTERS (ONE WAY)

- HVF110 #ACC AR110
- HVF210 #ACC AR210
- HVF310 #ACC AR310
- HVF410HD #ACC AR401



DUCTING

- HVF110 - #ACC WD1225 (12"x25')
- HVF210 (2 WAY)- #ACC WD1225 (12"x25')
- HVF310 (2 WAY)- #ACC WD1225 (12"x25')
- HVF210 (1 WAY)- #ACC WD1425 (14"x25')
- HVF310 (1 WAY)- #ACC WD1825 (18"x25')
- HVF410 (2 WAY)- #ACC WD1825 (18"x25')
- HVF410HD (1 WAY)- #ACC WD2025 (20"x25')

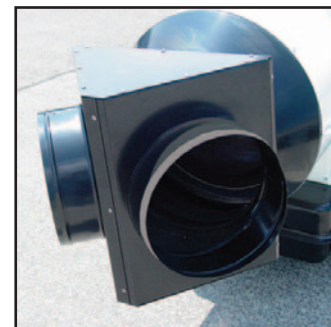

DUCT ADAPTERS (TWO WAY)

- HVF210 #ACC AR212
- HVF310 #ACC AR312
- HVF410HD #ACC AR402



FLUE STACK
#ACC EF1



FUEL PRESSURE GAUGE
#BIE 99AM003

HVF110 Electrical Schematic

For SN 21103001 and Beyond

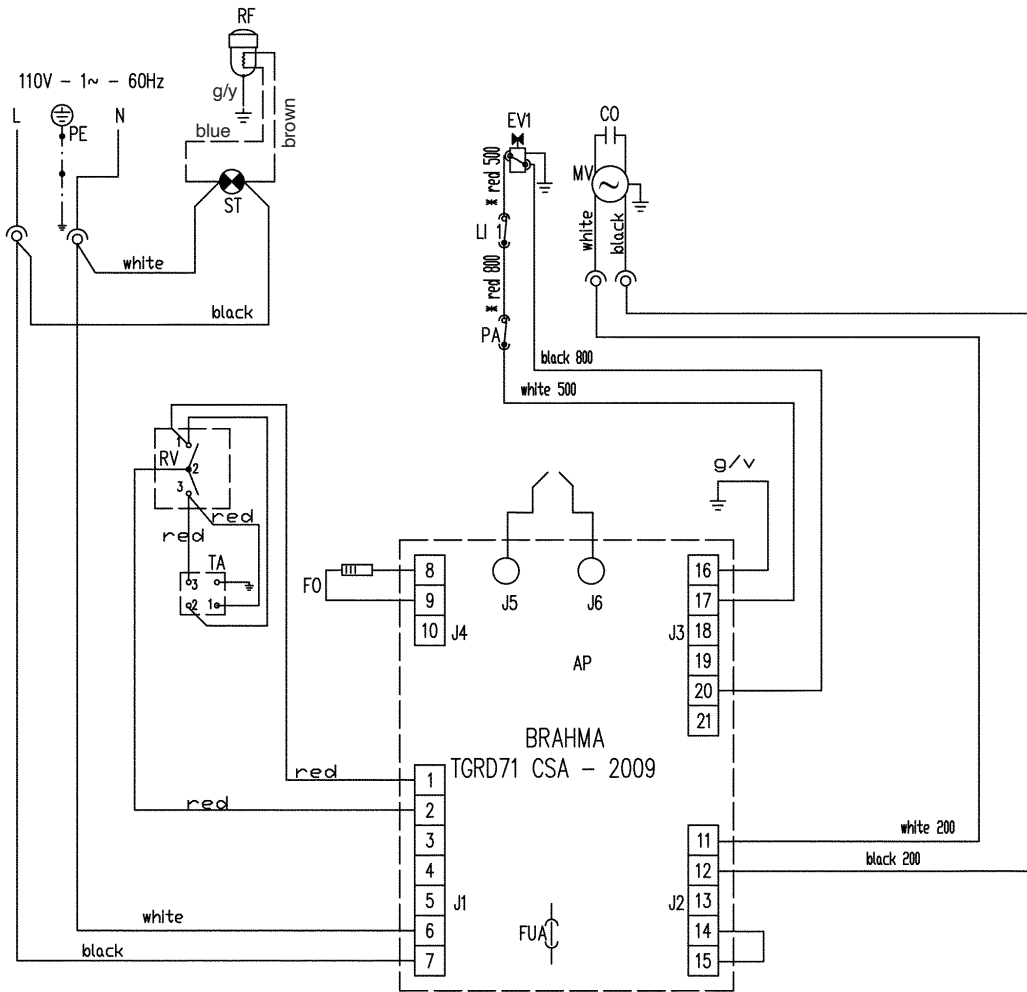

- | | |
|---|--------------------------------|
| FUA FUSE 6.3 A
P/N - BIE E10325 | TA ROOM THERMOSTAT PLUG |
| LI1 OVERHEAT THERMOSTAT | AP CONTROL BOX |
| EV1 SOLENOID VALVE 1° | PA AIR PRESSURE SWITCH |
| FO PHOTOCCELL | RF HEATED FILTER |
| CO CONDENSER (CAPACITOR) | |
| MV FAN MOTOR | |
| ST ELECTRIC PILOT LAMP | |
| RV CONTROL | |

RV3 (110)
RV1 (210,310)
RV (410)

Wiring Schematic For Digital Thermostat

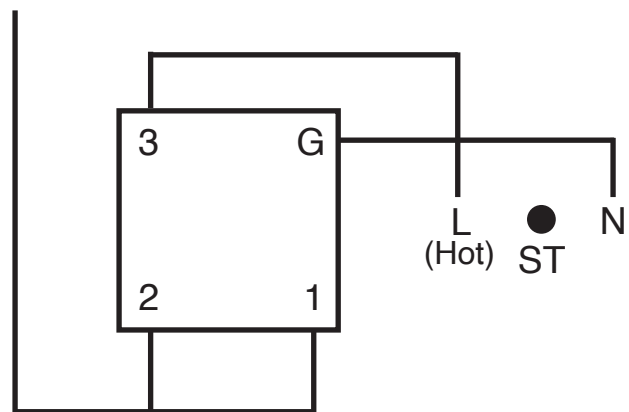

RV1 (110)
RV3 (210,310)
Term #2 on Brahma (410)



HVF110 Breakdown

For SN 21103001 and Beyond

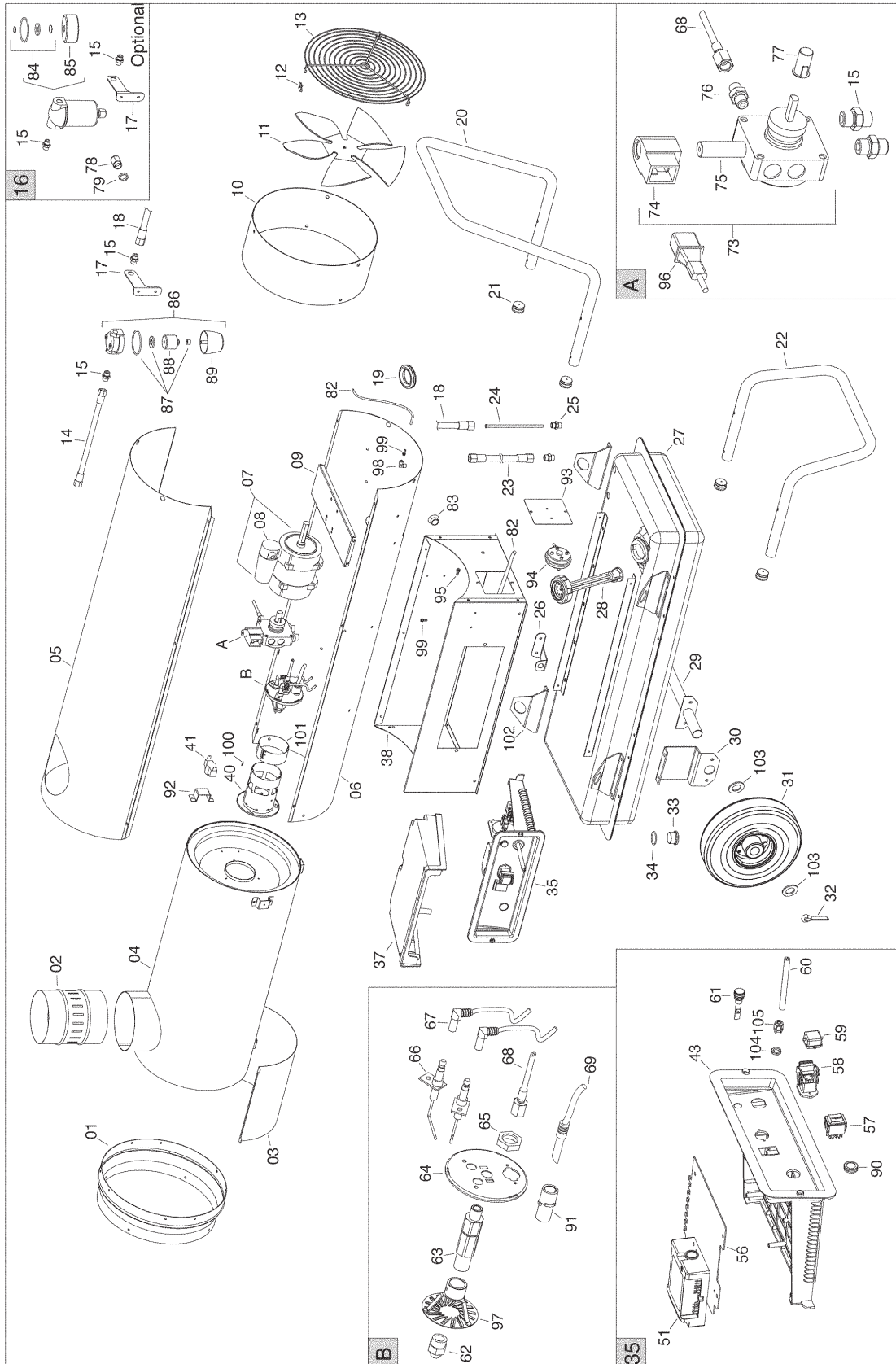

HVF110 Parts List

For SN 21103001 and Beyond*

POS	P/N	DESCRIPTION
01	BIE G06075-9010	Outlet cone
02	BIE G06077	Chimney fitting
02	BIE G06548	Chimney fitting starting w/SN 21109501
03	BIE G06079	Insulating panel combustion panel support
04	BIE G06301	Combustion chamber
05	BIE G06083-9010	Upper body
06	BIE G06216-9010	Lower body
07	BIE E10677-110	Motor 220W, 25uF *(AACO)
08	BIE E11233	Capacitor 20 uF *
09	BIE G06217	Motor support bracket
10	BIE G06070-9010	Air conveyer , fan protection
11	BIE T10207	Fan
12	BIE M20412	Lock plate , elastic
13	BIE P30165	Inlet grill
14	BIE I40330	Flex diesel pipe 16.53" tube
15	BIE I20104	Iron fitting , nipple FE 1/4" MM
16	BIE 02AC513	Diesel pre-heaters filter kit
17	BIE G06104-9005	Filter support bracket
18	BIE I40329	Flex diesel pipe 10.25"
19	BIE C30372	Cable protection
20	BIE P20174-9005	Handle
21	BIE C30355	Pipe cap. plug 25,oil
22	BIE P20175-9005	Support foot
23	BIE I40331	Flex diesel pipe 22.83"
24	BIE I30696	Suction pipe 8.66"
25	BIE I30737	Brass fitting , nipple
26	BIE G06068-9005	Power cord support , lead hook
27	BIE G06110-9005	Fuel tank 65L
28	BIE 02AC508	Cap with level control
29	BIE G06464-9005	Wheel axle
30	BIE G06106-9005	Wheels axle support bracket
31	BIE C10556	Wheel - Air filled
	BIE C10510	Wheel - Solid rubber
32	BIE M20507	Cotter pin
33	BIE I25020	Drain cap , plug
34	BIE C30375	O-ring 15 x 2.62
35	BIE G00249	El. control box - complete
37	BIE P50127	Control box cover
38	BIE G06405-9010	Base
40	BIE G06361	Blast tube
41	BIE E50109	Safety thermostat
43	BIE G06153	El. control box panel
51	BIE E40125	Flame control box, Brahma
56	BIE G06184	Support plate for electrical
57	BIE E10102-P	Switch
58	BIE E20640	Thermostat plug 4 pin w/clip

POS	P/N	DESCRIPTION
59	BIE E20665	Thermostat plug cover /socket cap
60	BIE E30443	Power cord *
61	BIE E11030	Lamp 230V
62	BIE T20361	Nozzle .55 x 80°W
63	BIE I33007	Nozzle support
64	BIE G06228	Burner support disc flange
65	BIE I31034	Brass lock nut
66	BIE E10248	Ignition electrode
67	BIE G02078	H.T. Cable connect.
68	BIE I40192	Micropipe 9.84"
69	BIE E50328-BR-VERDE	Photocell **
69	BIE E50334	Phototransistor starting w/SN 21109501
73	BIE T20429-1	Diesel pump Includes valve & solenoid coil
74	BIE T20118	Solenoid coil only
75	BIE T20117	Solenoid valve body
76	BIE I20115	Iron fitting
77	BIE E10513	Motor-pump coupling *
78	BIE E20953	Cable fastener
79	BIE E20954	Cable fastener nut
82	BIE I40335	Silicone pipe 39"
83	BIE C30319	Hole cap
84	BIE T20241	Filter seal kit
85	BIE T20242	Filter cartridge
86	BIE T20201	Diesel filter
87	BIE T20234	Filter seal kit
88	BIE T20206	Filter cartridge element
89	BIE T20212	Filter container
90	BIE E20418	Stop button protection
91	BIE E50327	Photoresistor support
91	BIE E50327-20	Photoresistor support starting w/SN 21109501
92	BIE G06221	Thermostat support bracket
93	BIE G06406-9010	Pressure switch support bracket
94	BIE E50440	Pressure switch
95	BIE I31131	Brass hose connection
96	BIE T20442	Solenoid valve cable
97	BIE G01077	Diffuser ring
98	BIE I20325-2	Fitting
99	BIE I31130	Brass hose connection
100	BIE E20671	Terminal board
101	BIE G06183	Air adjustment shutter
102	BIE 02AC511	Lifting bracket
103	BIE M20111	Washer

Optional Thermostat

ACC TH1DF Optional thermostat
 ACC 7979K62 4 pin plug insert
 ACC 7979K68 4 pin plug cover

* Note for S/N Starting 21105001

POS	P/N	DESCRIPTION
07	BIE E10770	Motor 200W 25uF (SIMEL)
08	BIE E10770-1	Capacitor 25uF
60	BIE E30443-1	Power cord
77	BIE E10698	Motor pump coupling
104	BIE E20965	Cable fastener nut
105	BIE E10964	Cable fastener

** E50328-BR-VERDE replaces E50328

HVF210 Electrical Schematic for SN 21202501 and Beyond

HVF310 Electrical Schematic for SN 21302501 and Beyond

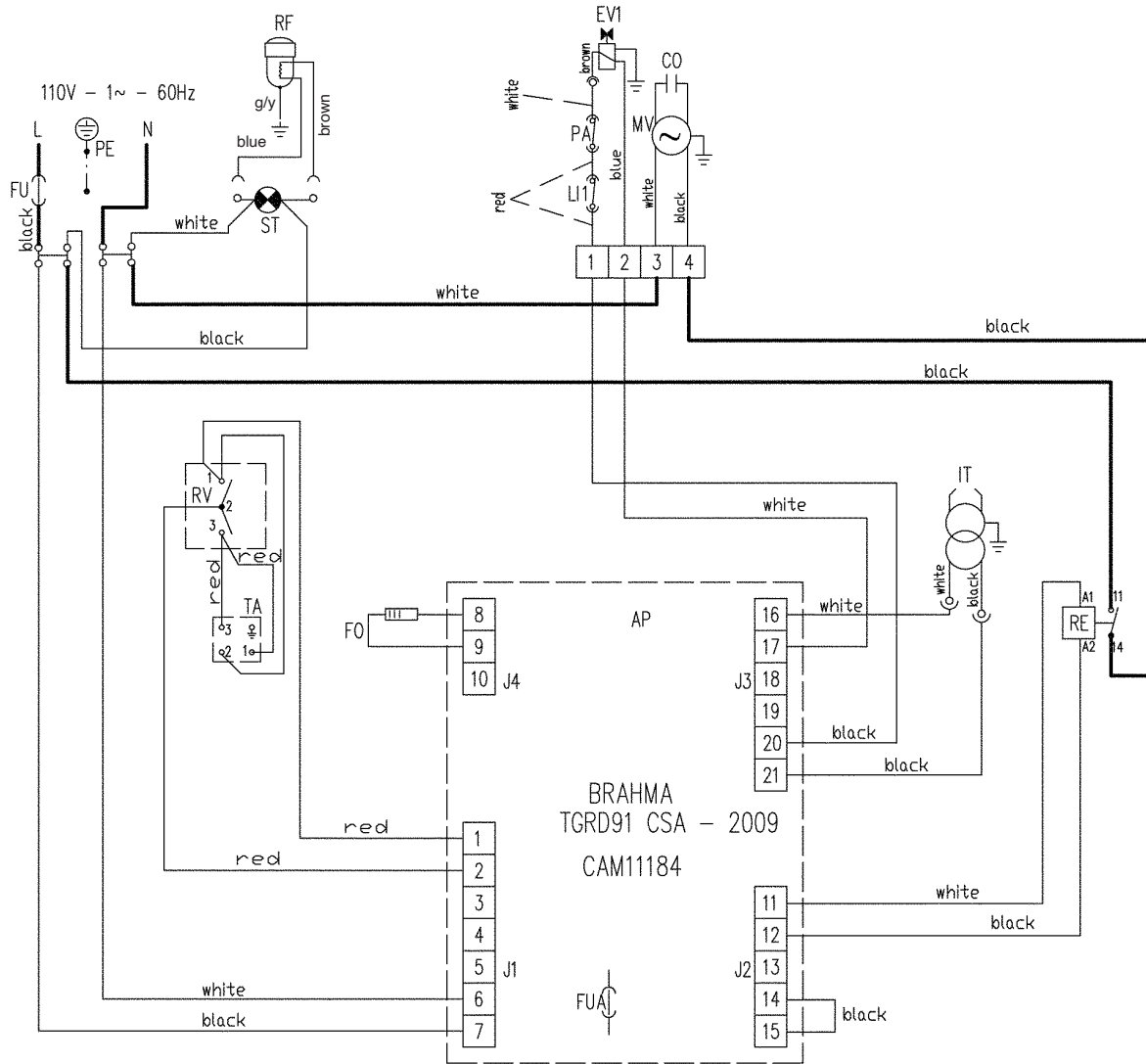

FU FUSE 20 A

RV CONTROL

IT TRANSFORMER H.V.

TA ROOM THERMOSTAT PLUG

LI1 OVERHEAT THERMOSTAT

RE RELAY

EV1 SOLENOID VALVE 1°

AP CONTROL BOX

FO PHOTOCCELL

RF HEATED FILTER

CO CONDENSER (CAPACITOR)

PA AIR PRESSURE SWITCH

MV FAN MOTOR

FUA FUSE 6,3 A
P/N - BIE E10325

ST ELECTRIC PILOT LAMP

HVF210 Breakdown

For SN 21202501 and Beyond

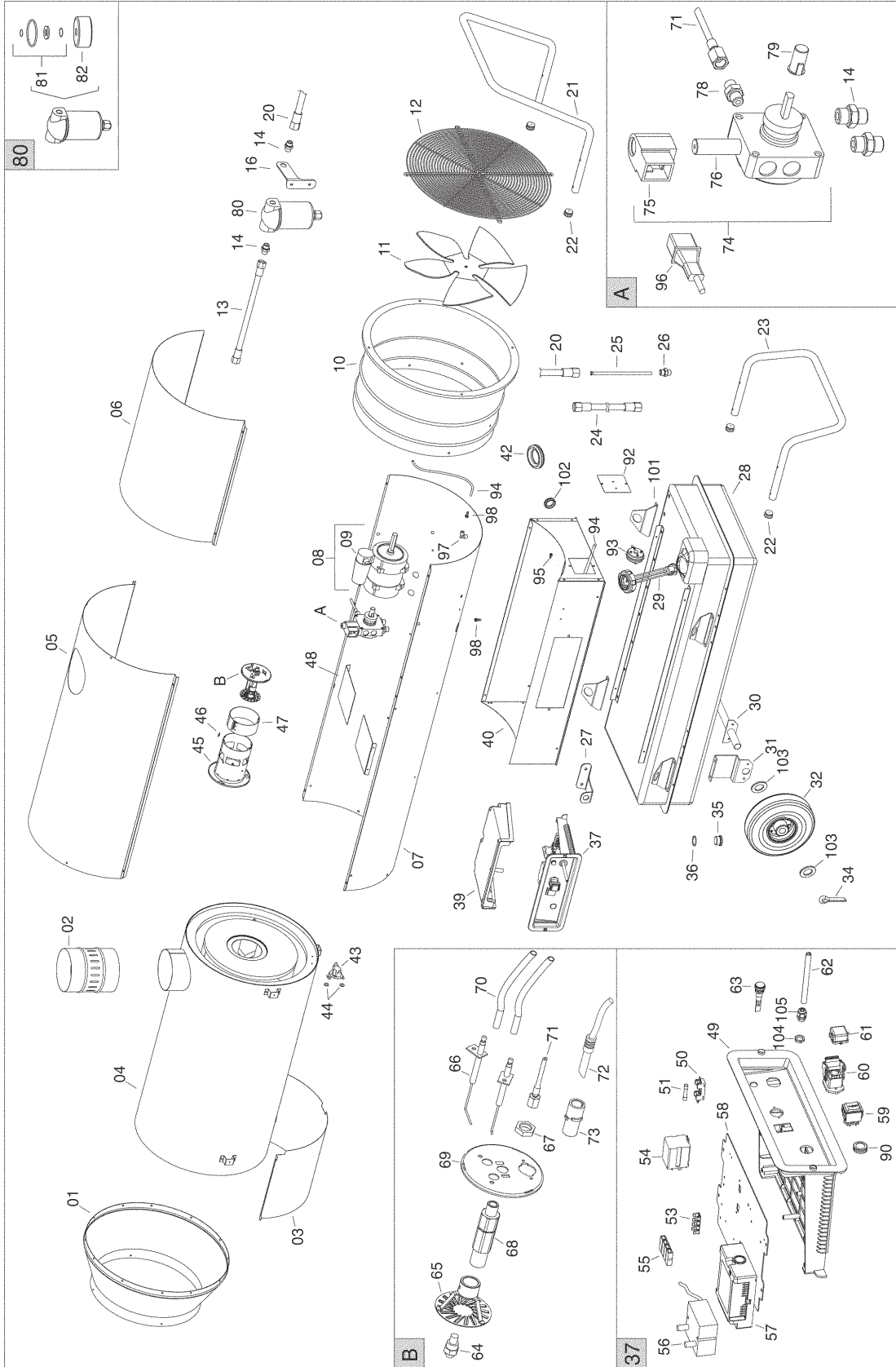

HVF210 Parts List

For SN 21202501 and Beyond*

POS	P/N	DESCRIPTION
01	BIE G06113-9010	Outlet cone
02	BIE G06077	Chimney 150 MM
03	BIE G06174	Insulating panel comb. chamber support
04	BIE G06176	Combustion chamber
05	BIE G06119-9010	Upper body
06	BIE G06121-9010	Inspection panel
07	BIE G06178-9010	Lower body
08	BIE E10678-110	Motor AACO motor (pre 21204001)*
09	BIE E11230	Capacitor 40uF *
10	BIE G06125-9010	Air conveyor /motor flange
11	BIE T10260	Fan
12	BIE P30169	Inlet grill
13	BIE I40330	Flex diesel pipe 16.53" tube
14	BIE I20104	Iron fitting, nipple FE 1/4" MM
16	BIE G06104-9005	Filter support bracket
20	BIE I40329	Flex diesel pipe 10.24"
21	BIE P20176-9005	Handle
22	BIE C30355	Pipe cap, plug oil
23	BIE P20177-9005	Support foot
24	BIE I40331	Flex diesel pipe 22.83"
25	BIE I30696	Suction pipe 8.66"
26	BIE I30737	Brass fitting, nipple
27	BIE G06068-9005	Power cord support
28	BIE G06127-9005	Fuel tank
29	BIE 02AC508	Cap with level control
30	BIE G06465-9005	Wheel axle
31	BIE G06106-9005	Wheels axle support bracket
32	BIE C10556	Wheel - Air filled
	BIE C10510	Wheel - Hard rubber
34	BIE M20507	Cotter pin
35	BIE I25020	Drain cap
36	BIE C30375	O-ring
37	BIE G00248	El. control box - complete
39	BIE P50127	Control box cover
40	BIE G06407-9010	Base
42	BIE C30372	Cable protection
43	BIE E50102	Safety thermostat
44	BIE M20107	Washer
45	BIE G06181	Blast tube
46	BIE E20671	Grounding terminal
47	BIE G06183	Air adjustment shutter
48	BIE G01061-1	Air flap, right
	BIE G01061-2	Air flap, left
49	BIE G06153	El. control box panel drawer only
50	BIE E20508	Fuse holder

Optional Thermostat

ACC TH1DF Optional thermostat
 ACC 7979K62 4 pin plug insert - 3 pole connector
 ACC 7979K68 4 pin plug cover only

POS	P/N	DESCRIPTION
51	BIE E10313	Fuse 20A
53	BIE E20319	Ground terminal board
54	BIE E11125	Relay
55	BIE E20305	Terminal board
56	BIE E10930	H.T. Transformer
57	BIE E40124	Flame control box Brahma
58	BIE G06073	Support plate
59	BIE E10102-P	Switch
60	BIE E20640	Thermostat plug w/clip
61	BIE E20665	Thermostat plug cover
62	BIE E30443	Power cord *
63	BIE E11030	Lamp
64	BIE T20355	Nozzle 1.1 x 80°W
65	BIE G01077	Diffuser ring
66	BIE E10215	Ignition electrode
67	BIE I31034	Brass lock nut
68	BIE I33005	Nozzle support
69	BIE G06228	Burner support disc flange
70	BIE G02078	H.T. Cable connect.
71	BIE I40192	Micropipe 9.84"
72	BIE E50328-BR-VERDE	Photocell **
72	BIE E50334	Phototransistor starting w/SN 21207501
73	BIE E50327	Photoresistor support
73	BIE E50327-20	Photoresistor support starting w/SN 21207501
74	BIE T20410-1	Diesel pump Includes valve & solenoid coil
75	BIE T20118	Solenoid coil
76	BIE T20117	Solenoid valve body
78	BIE I20115	Iron fitting nipple
79	BIE E10513	Motor-pump coupling *
80	BIE T20239	Filter Only
	BIE 02AC550	Preheater kit complete
	BIE T20239EL	Element for filter cartridge
81	BIE T20241	Filter seal kit
82	BIE T20242	Filter cartridge
90	BIE E20418	Stop button protection
92	BIE G06406-9010	Pressure switch support bracket
93	BIE E50440	Pressure switch
94	BIE I40335	Silicone pipe 39"
95	BIE I31131	Brass hose connection
96	BIE T20442	Solenoid valve cable
97	BIE I20325-1	Fitting
98	BIE I31130	Brass hose connection
101	BIE 02AC511	Lifting bracket
102	BIE C30323	Cable protection
103	BIE M20111	Washer

* Note for S/N Starting 21204001

POS	P/N	DESCRIPTION
08	BIE E10771	Motor (SIMEL)
09	BIE E10771-1	Capacitor 30uF
62	BIE E30443-1	Power cord
79	BIE E10698	Motor pump coupling
104	BIE E10965	Cable fastener nut
105	BIE E10964	Cable fastener

** E50328-BR-VERDE replaces E50328



HVF310 Breakdown

For SN 21302501 and Beyond

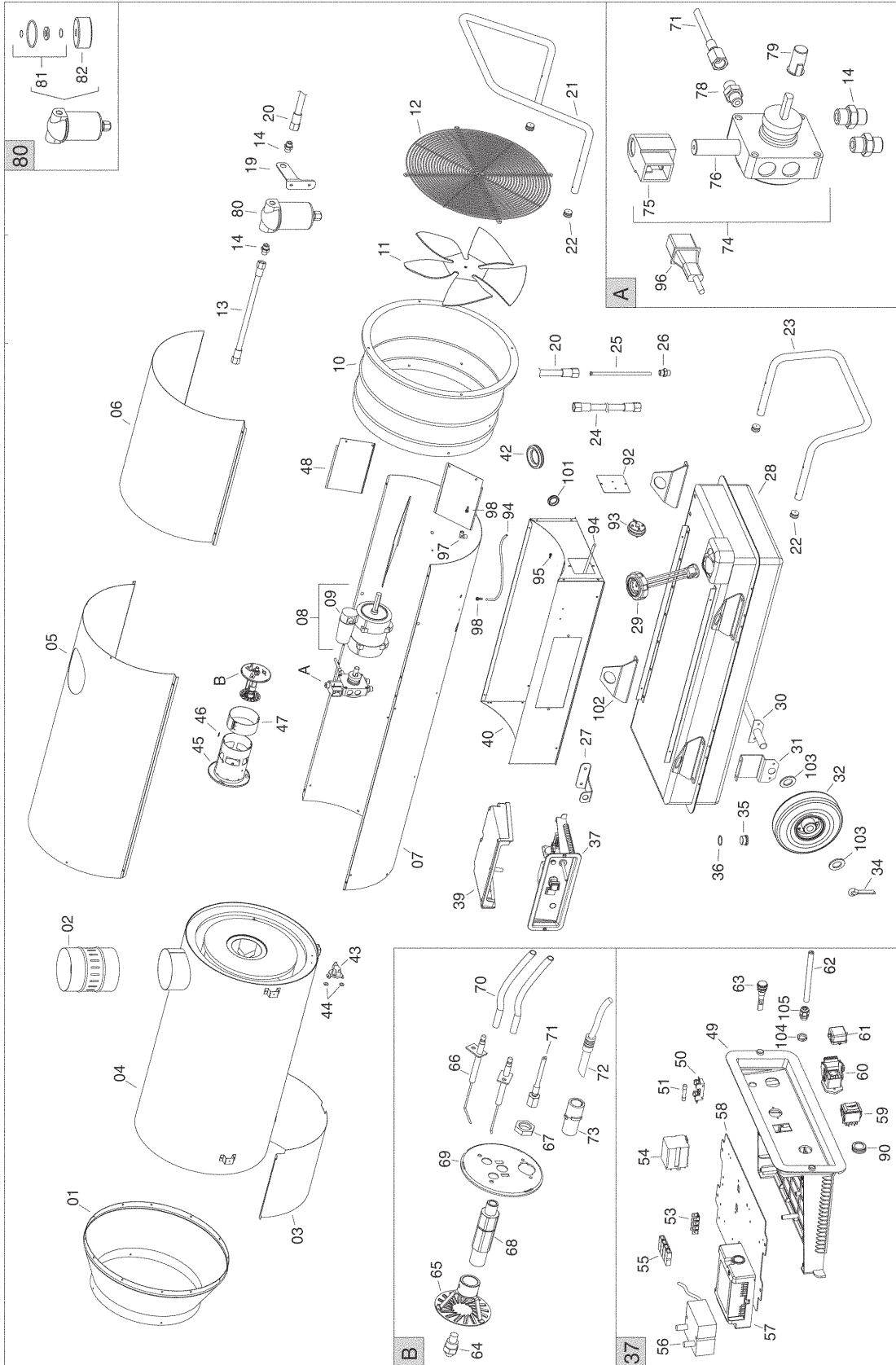

HVF310 Parts List

For SN 21302501 and Beyond*

POS	P/N	DESCRIPTION
01	BIE G06114-9010	Outlet cone
02	BIE G06077	Chimney 150 MM
03	BIE G06175	Insulating panel
04	BIE G06177-09	Combustion chamber
05	BIE G06413-9010	Upper body
06	BIE G06122-9010	Inspection panel
07	BIE G06179-9010	Lower body
08	BIE E10704-110	Motor * (AACO)
09	BIE E11249	Capacitor 80uF *
10	BIE G06126-9010	Air conveyor /motor flange
11	BIE T10261	Fan
12	BIE P30129	Inlet grill
13	BIE I40330	Flex diesel pipe 16.54"
14	BIE I20104	Iron fitting, nipple
19	BIE G06104-9005	Filter support bracket
20	BIE I40329	Flex diesel pipe 10.24"
21	BIE P20176-9005	Handle
22	BIE C30355	Pipe cap
23	BIE P20180-9005	Support foot
24	BIE I40331	Flex diesel pipe 22.83"
25	BIE I30698	Suction pipe 11.41"
26	BIE I30737	Brass fitting
27	BIE G06068-9005	Power cord support
28	BIE G06146-9005	Fuel tank
29	BIE 02AC510	Cap with level control
30	BIE G06465-9005	Wheel axle (new version)
31	BIE G06107-9005	Wheels axle support bracket
32	BIE C10556	Wheel -Air Filled
	BIE C10510	Wheel -Hard Rubber
34	BIE M20507	Cotter pin
35	BIE I25020	Drain cap
36	BIE C30375	O-ring
37	BIE G00248	El. control box
39	BIE P50127	Control box cover
40	BIE G06414-9010	Base
42	BIE C30372	Cable protection
43	BIE E50102	Safety thermostat
44	BIE M20107	Washer
45	BIE G06266	Blast tube
46	BIE E20671	Terminal board .grounding
47	BIE G06183	Air adjustment shutter
48	BIE G06394	Air conveyor
49	BIE G06153	El. control box panel
50	BIE E20508	Fuse holder
51	BIE E10313	Fuse 20A

POS	P/N	DESCRIPTION
53	BIE E20319	Ground terminal board
54	BIE E11125	Relay
55	BIE E20305	Terminal board
56	BIE E10930	H.T. Transformer
57	BIE E40124	Flame control box
58	BIE G06073	Support plate
59	BIE E10102-P	Switch
60	BIE E20640	Thermostat plug
61	BIE E20665	Thermostat plug cover/socket cap
62	BIE E30443	Power cord *
63	BIE E11030	Lamp
64	BIE T20356	Nozzle 1.5 x 80°W
65	BIE G01077	Diffuser ring
66	BIE E10215	Ignition electrode
67	BIE I31034	Brass lock nut
68	BIE I33005	Nozzle support
69	BIE G06228	Burner support disc
70	BIE G02078	H.T. Cable connect.
71	BIE I40192	Micropipe 9.84"
72	BIE E50328-BR-VERDE	Photocell **
72	BIE E50334	Phototransistor starting w/SN 21307501
73	BIE E50327	Photoresistor support
73	BIE E50327-20	Photoresistor support starting w/SN 21307501
74	BIE T20411-1	Diesel pump Includes valve & solenoid coil
75	BIE T20118	Solenoid coil
76	BIE T20117	Solenoid valve body
78	BIE I20115	Iron fitting, nipple
79	BIE E10514	Motor-pump coupling *
80	BIE T20239	Filter only
	BIE 02AC550	Preheater kit complete
	BIE T20239EL	Element for filter cartridge
81	BIE T20241	Filter seal kit
82	BIE T20242	Filter cartridge
90	BIE E20418	Stop button protection
92	BIE G06406-9010	Pressure switch support bracket
93	BIE E50440	Pressure switch 100Pa
94	BIE I40335	Silicone pipe 39"
95	BIE I31131	Brass hose connection
96	BIE T20442	Solenoid valve cable
97	BIE I20325-1	Fitting
98	BIE I31130	Brass hose connection
101	BIE C30323	Cable protection
102	BIE 02AC511	Lifting bracket
103	BIE M20111	Washer

Optional Thermostat

ACC THIDF Optional thermostat
 ACC 7979K62 4 pin plug insert
 ACC 7979K68 4 pin plug cover

* Note for S/N Starting 21304001

POS	P/N	DESCRIPTION
08	BIE E10772	Motor (SIMEL)
09	BIE E10772-1	Capacitor 100uF
62	BIE E30443-1	Power cord
79	BIE E10698	Motor pump coupling
104	BIE E20965	Cable fastener nut
105	BIE E20964	Cable fastener



** E50328-BR-VERDE replaces E50328

OPERATING DIAGRAM HVF 410HD

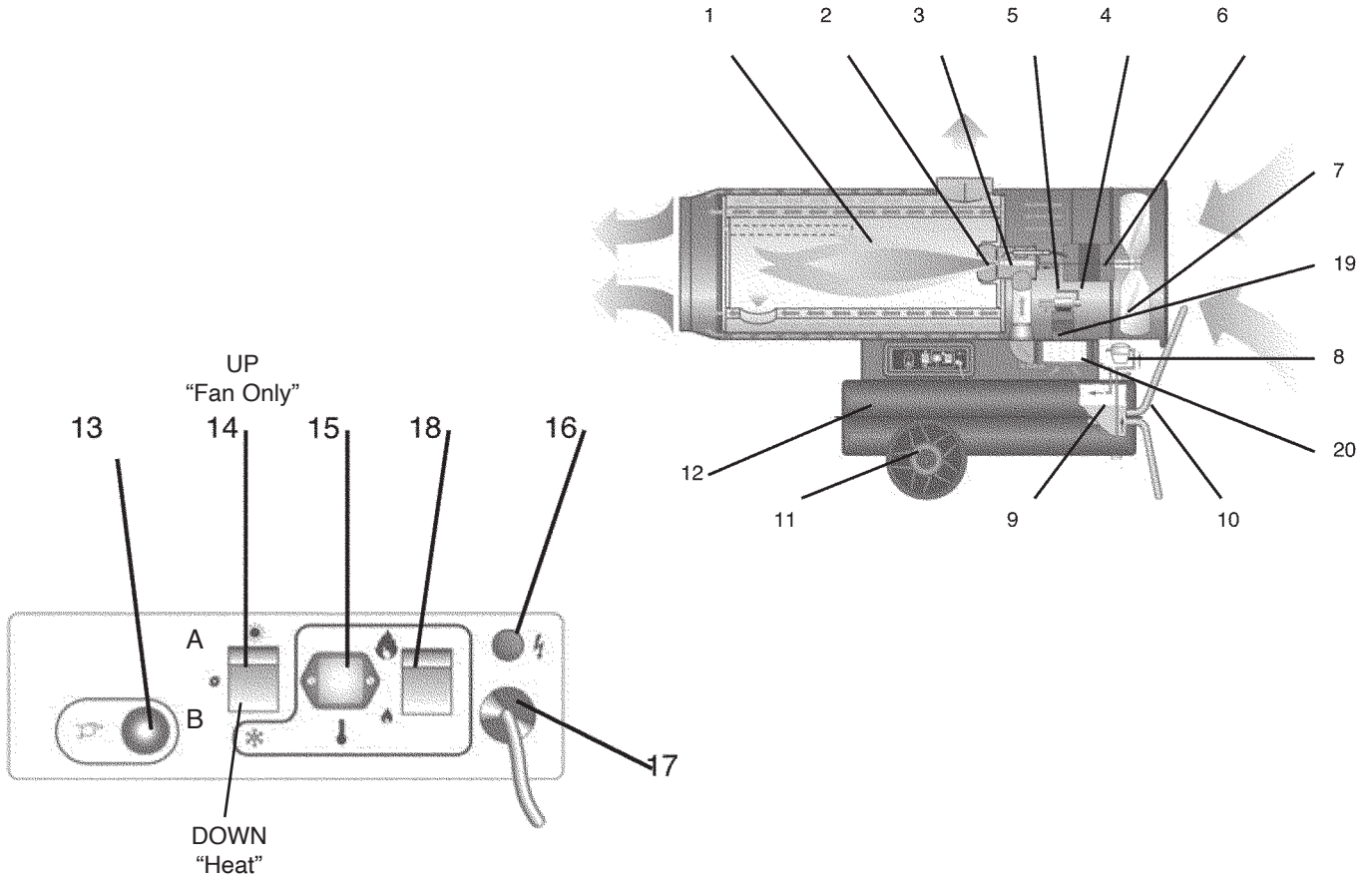

- | | | | |
|----|--------------------|----|--|
| 1 | COMBUSTION CHAMBER | 11 | WHEEL |
| 2 | BURNER | 12 | FUEL TANK |
| 3 | NOZZLE | 13 | RESET BUTTON WITH CONTROL LAMP |
| 4 | SOLENOID VALVE | 14 | MAIN SWITCH
A-Fan Only
B-Heat |
| 5 | DIESEL PUMP | 15 | ROOM THERMOSTAT PLUG - Jumper or thermostat only |
| 6 | COOLING FAN MOTOR | 16 | CONTROL LAMP |
| 7 | FAN | 17 | POWER CORD |
| 8 | FUEL FILTER | 18 | HIGH - LOW THERMAL POWER SWITCH |
| 9 | FUEL CIRCUIT | 19 | BURNER MOTOR |
| 10 | SUPPORT/HANDLE | 20 | AIR COMBUSTION ADJUSTEMENT |

IMPORTANT

Before using the space heater, carefully read all of the instructions and follow them scrupulously. The manufacturer cannot be held responsible for damage to persons and/or property caused by improper use of the equipment. This instruction manual is an integral part of the equipment and must therefore be stored carefully and passed on with the unit in the event of a change of ownership.

GENERAL RECOMMENDATIONS

The space heaters run on heating oil #2. Direct combustion versions send hot air and combustion products into the room, while indirect combustion versions are fitted with a flue to discharge the fumes through the chimney.

Always follow local ordinances and codes when using this heater:

- Follow the instructions in this booklet very carefully;
- THE INSTALLATION OF THE UNIT SHALL BE IN ACCORDANCE WITH THE REGULATIONS OF THE AUTHORITIES HAVING JURISDICTION. Also, as a recommended installation practice reference should be made to the current issue of CSA B139, Installation Code for Oil Burning Equipment in Canada and NFPA 31 Standard for the Installation of Oil-Burning Equipment in the USA;
- Use only in places free of flammable vapours or high dust content;
- Never use heater in immediate proximity of flammable materials (the minimum distance must be 5 ft.);
- Make sure fire fighting equipment is readily available;
- Ensure that the machine resting surface or ground is not made of flammable material;
- Make sure sufficient fresh outside air is provided according to the heater requirements. Direct combustion heaters should only be used in well vented areas in order to avoid carbon monoxide poisoning;
- A rough estimate of opening required for each gallon (US) of capacity is one square foot for indirect-fired heater and three square foot at heater level, for direct-fired heaters;
- the indirect combustion heater is installed near a chimney to take away the fumes (see the paragraph "CHIMNEY LAY-OUT RECOMMENDATION") and connected to an electrical switchboard;
- Never block air inlet (rear) or air outlet (front);
- In case of very low temperatures add kerosene to the heating oil;
- Make sure heater is always under surveillance and keep children and animals away from it;
- Before starting the heater always check free rotation of ventilator;
- Unplug heater when not in use.

SAFETY DEVICES

The heater is fit with an electronic device that controls the flame and the maximum safe temperature by means of a photocell, two overheat thermostats, an air pressure switch and a fan start thermostat.

The electronic device controls start/stop times and trips the safety in case of malfunctions. It has reset button (13) that can assume different colours (Function Light) depending on the function mode:

- off: heater is in stand-by, waiting for heating call ;
- steady green: heater functioning normally;
- steady red: heater in safety stop;

To restart heating after a safety stop, push reset button (13) for 3 seconds.

Warning



NEVER do more than two restarts in a row: uncombusted diesel fuel may accumulate in the combustion chamber and suddenly flare up at the next restart.

If the safety stop persists, you have to find and eliminate the cause of the stop before you restart the heater.

Warning



See "TROUBLESHOOTING" to identify the cause of the malfunction.

OPERATION

Before switching on the heater and, therefore, before plugging it into the electrical power supply, check that the power supply specifications are the same as those stated on the identification plate.

Warning



- **The power line must be grounded and fitted with a residual current circuit breaker.**
- **The heater plug must be inserted into a socket equipped with a mains switch.**

The heater must be placed on a flat, stable, and levelled surface in order to prevent it from overturning and/or diesel leaks from the tank filler cap.

The heater can work in "ventilation" mode turning the switch (14) to ☼ : the fan motor starts, while the burner is off.

The heater works in "heating" mode, turning the switch (14) to * : the burner motor start, immediately followed by ignition and combustion. When the combustion chamber becomes hot, the coolin fan motor starts.

To select the heating power level, turn the swith (18) to the position corrspondent to the first stage (I S) or second stage (II S).



In heating mode the heater can run automatically when connected to a thermostat. Note: if not operating with thermostat the plate plug(64) must remain connected to panel.

When unit is started for the first time or is started after the oil tank has been totally emptied, the diesel flow to the burner may be impaired by air in the circuit. In this case the control box will cut out the heater and it might be necessary to renew the starting procedure once by depressing the reset button (13).

If the heater does not function, the first things to do are:

1. Check that the tank still contains some diesel;
2. Push reset button (13);
3. If the heater still does not function, see "TROUBLESHOOTING" to identify the cause of the malfunction.

HVF 410HD

Warning



Never stop the machine by unplugging the electrical plug: this could cause overheating.

STOPPING THE HEATER

Set main switch (14) on "0" position or turn thermostat or other control device on lowest setting.

The flame goes out and the fan continues to work for approximately 90 sec. cooling the combustion chamber.

TRANSPORT

Warning



Before moving the heater:

- Stop the heater as indicated in the "STOP" paragraph;
- Cut electrical power by removing the plug from the electrical socket;
- Wait until the heater cools.

Before moving the heater, make sure the oil tank cap is securely attached.

Warning



Diesel may leak during handling and transport: the fuel tank cap is not sealed. This allows air to enter and allows the tank to be emptied while the heater is running.

The heater can be supplied in a mobile version (with wheels) or wall version mounted on a support structure with anchors for fastening by means of ropes or chains. To move the mobile version, just grip the heater by the support handle and roll it on the wheels. The second version must be lifted by using a lift truck or similar equipment.

In this case, make sure that the ropes and/or chains are securely attached and that they are in perfect condition before you start to move the heater.

MAINTENANCE

To ensure correct heater function, you have to clean the combustion chamber, burner, and fan at regular intervals.

Warning



Before starting any maintenance procedure, ALWAYS:

- Stop the heater as indicated in the "STOP" paragraph;
- Cut electrical power by removing the plug from the electrical socket;
- Wait until the heater cools.

Every 50 hours of operation:

- Disassemble the filter cartridge, remove it, and clean it with clean diesel fuel;
- Disassemble the external cylindrical fairing and clean the inside and the fan blades;
- Check the condition of the leads and of the high-voltage connections to the electrodes;
- Disassemble the burner and clean all of its parts. Clean the electrodes and set the gap to the value specified

CHIMNEY LAY-OUT SUGGESTED RECOMMENDATIONS

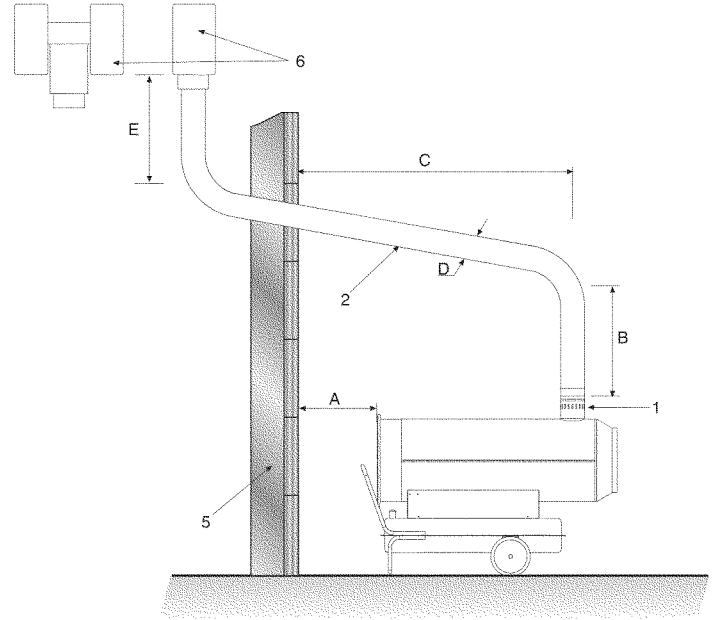
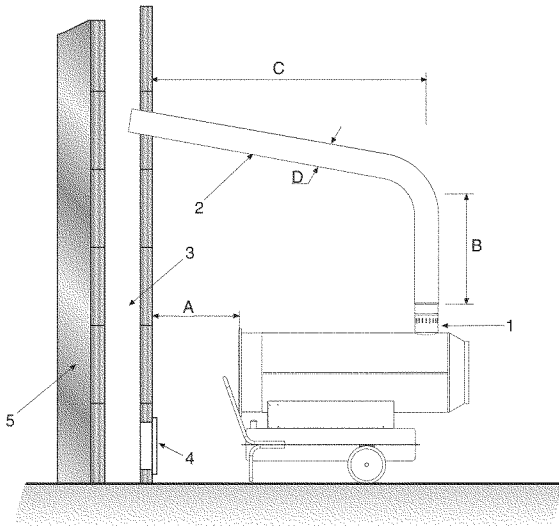

DESCRIPTION

ENGLISH

- A) Minimal 3 ft
- B) Minimal 3 ft
- C) The shortest
- D) The same or bigger than the outlet collar diameter of heater
- E) Minimal 3 ft
- 1) Anti-wind device provided with the heater
- 2) Horizontal crossing with minimal upside angle pitch of 5°
- 3) Chimney 8" x 8" minimal
- 4) Chimney anti-explosion flap door
- 5) External seating wall
- 6) Chimney ending H shape

Have your installation checked by local authority.

MINIMUM CLEARANCES TO COMBUSTIBLES

Heater; outlet 10 ft, front 3 ft, rear 3 ft, side 1 ft, ceiling 6 ft, flue 1 ft

FLUE CONNECTIONS DIAGRAM

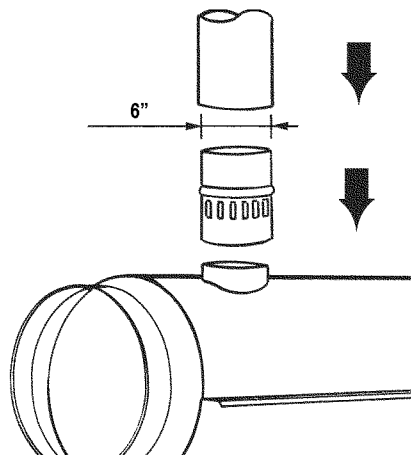

HVF410HD Electrical Schematic

SN 21801001 and Beyond

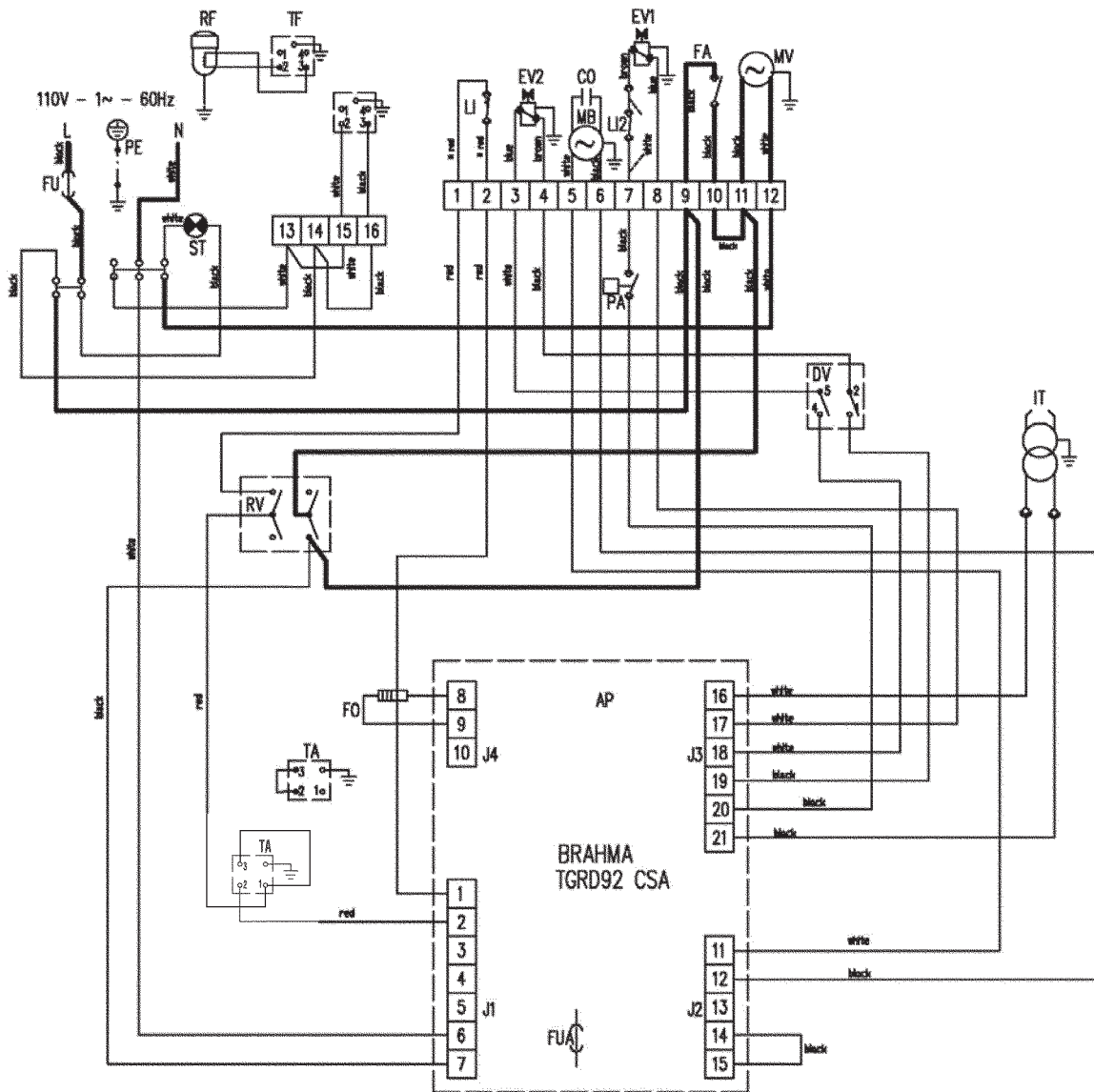

AP	CONTROL BOX	CO	CAPACITOR	FA	FAN THERMOSTAT
TA	ROOM THERMOSTAT PLUG	IT	TRANSFORMER H.V.	PA	AIR PRESSURESWITCH
ST	ELECTRIC PILOT LAMP	MV	FAN MOTOR	FO	PHOTOCELL
FU	FUSE 20 A	FUA	FUSE 6.3 A P/N - BIE E10325	DV	HIGH - LOW THERMAL POWER SWITCH
LI1	OVERHEAT THERMOSTAT	EV2	SOLENOID VALVE II° Stage	LI2	OVERHEAT SAFETY THERMOSTAT
EV1	SOLENOID VALVE I° Stage	RV	CONTROL SWITCH	RF	HEATED FILTER
MB	BURNER MOTOR				

HVF410HD Breakdown SN 21801001 and Beyond

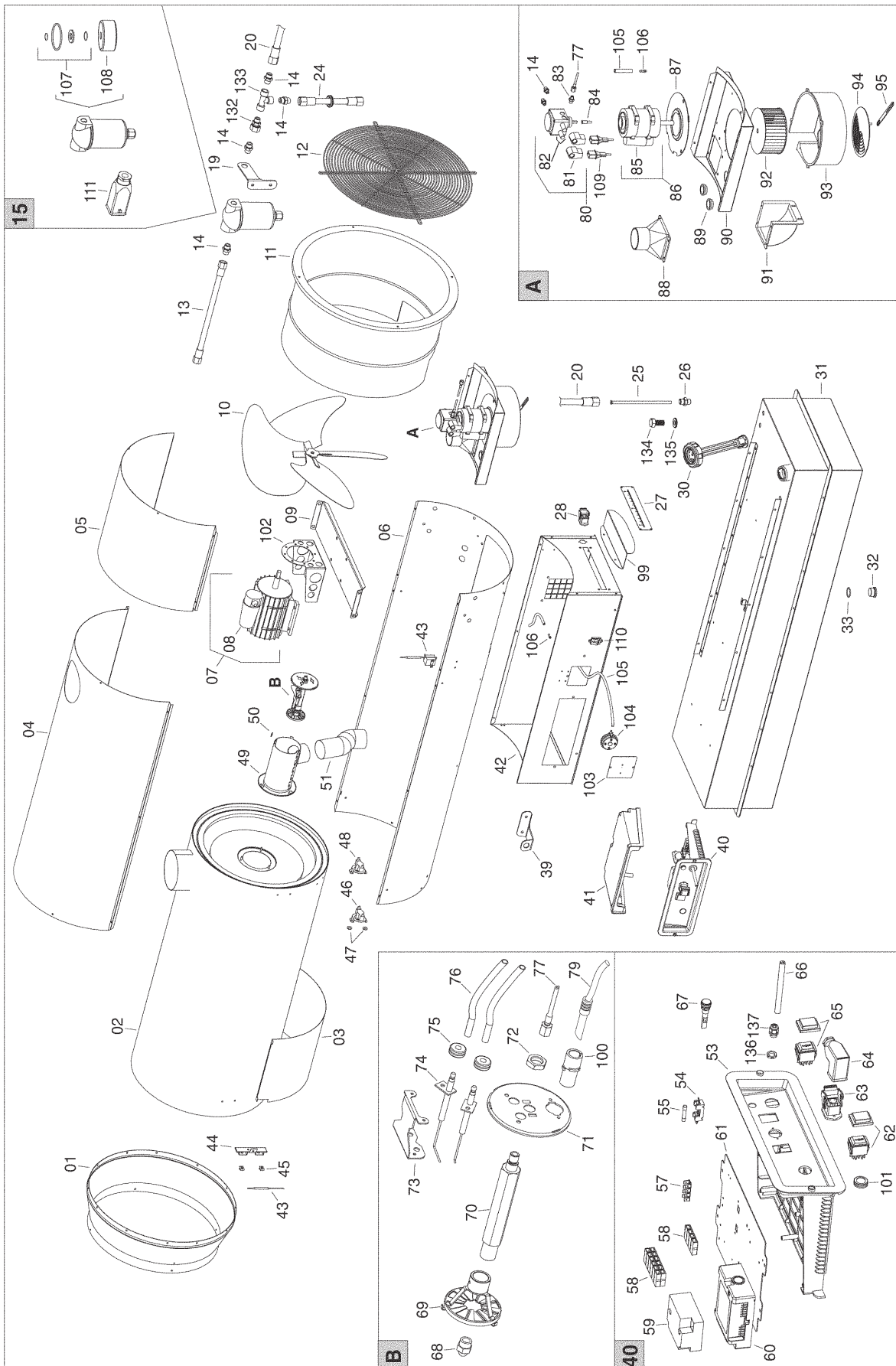

HVF410HD Breakdown SN 21801001 and Beyond

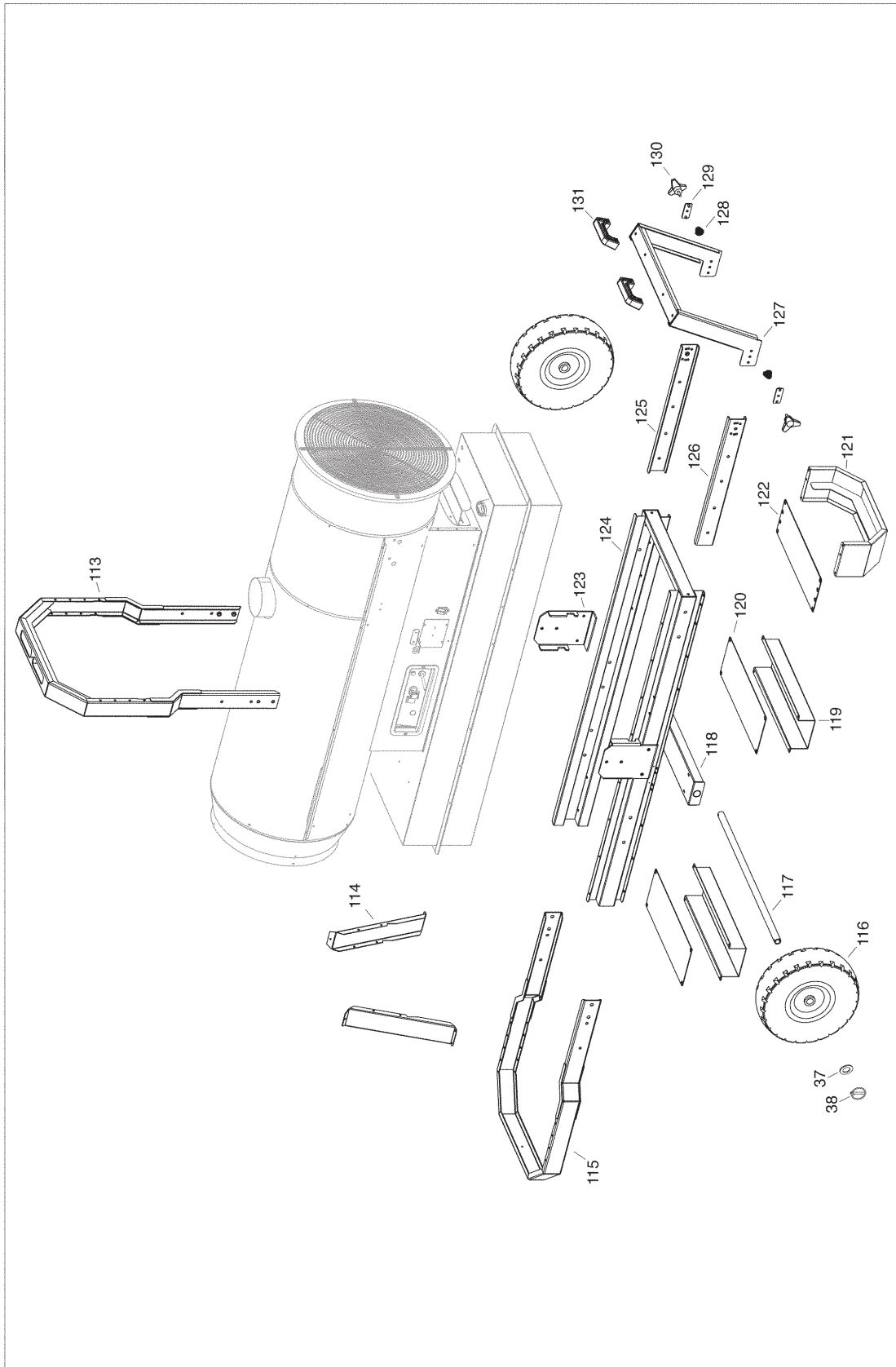

HVF410HD Parts List SN 21801001 and Beyond*

Pos.	Cod.	PART LIST
01	BIE G06185-9010	Outlet cone
02	BIE G06186	Combustion chamber
03	BIE G06187	Combustion chamber support
04	BIE G06188-9010	Upper body
05	BIE G06189-9010	Cover inspection
06	BIE G06429-9010	Lower body
07	BIE E10695-110	Motor 750W with capacitor 50mF, 80mF(AACO)*
08	BIE E11242	Capacitor 50 μ F *
09	BIE G06191	Motor flange
10	BIE T10267	Fan Ø550 18°
11	BIE G06192-9010	Air flap
12	BIE P30151	Inlet grille
13	BIE I40330	Tube BP 1/4" FF L.420mm 16.54"
14	BIE I20104	1/4" MM fitting
15	BIE T20239	Oil pre-heaters filter 1/4"
19	BIE G06104-9005	Filter support
20	BIE I40329	Tube BP 1/4" FF L.260mm 10.24"
24	BIE I40331	Tube BP 1/4" FF L.580mm 22.83"
25	BIE I30698	L.290mm suction pipe 11.41"
26	BIE I30737	OT 1/4" M - M12x1,75 M fitting
27	BIE G06193	Air adjustment panel
28	BIE E20640	Thermostat plug 4P+T
30	BIE 02AC510	Plug with level control L=290
31	BIE G06427-9005	Fuel tank 57 US gal
32	BIE I25020	Drain plug M16x1,5 mm
33	BIE C30375	OR Ø16 x 2,62 mm
37	BIE M20111	Washer Ø26 x Ø44 x 4 mm
38	BIE M20505	Wheel locking pin
39	BIE G06068-9005	Power lead hook
40	BIE G00332	El. componets drawer
41	BIE P50127	Control box cover
42	BIE G06428-9010	Base
43	BIE E50767	Thermostat TY95A 105 °C Campini
44	BIE G06196	Thermostat bulb metal bracket
45	BIE M20413	Bulb support
46	BIE E50102	Limit Thermostat
47	BIE M20107	Washer Ø5 x Ø15 x 1,5 mm
48	BIE E50104	Fan Thermostat
49	BIE G06197	Blast tube
50	BIE E20671	Terminal board
51	BIE I40804	Air duct L=220 mm
52	BIE E11229	Capacitor 80 μ F
53	BIE G06154	Electr. componets drawer
54	BIE E20508	Fuse holder
55	BIE E10324	Fuse (6x30) 25A
57	BIE E20319	Terminal board
58	BIE E20305	Terminal board
59	BIE E10939	Transformer H.T. COFI
60	BIE E40121	Control box BRAHMA TGRD 92 120V
61	BIE G06073	Plate for electrical components
62	BIE E10102-P	Switch 0 - 1
63	BIE E20640	Thermostat plug 3P+T

* Note for S/N Starting 21801001

POS	P/N	DESCRIPTION
07	BIE E10772	Motor (SIMEL)
08	BIE E10772-1	Capacitor 100uF
84	BIE E10698	Motor pump coupling
85	BIE E10770-1	Capacitor 250uF
86	BIE E10770	Motor
136	BIE E20965	Cable fastener nut
137	BIE E20964	Cable fastener

Optional Thermostat

ACC TH1DF Optional thermostat
 ACC 7979K62 4 pin plug insert-3 pole
 ACC 7979K68 4 pin plug cover

Pos.	Cod.	PART LIST
64	BIE E20675	Plate plug 90° 3P + T
65	BIE E10112-P	Switch 0 - 1
66	BIE E30443 -1	El. wire with plug and cable fastener
67	BIE E11030	Lamp
68	BIE T20357	Nozzle 2,0 GPH 80° W
69	BIE G06225	Turbo disc
70	BIE I33006	Nozzle support
71	BIE G06226	Burner flange Ø 102mm
72	BIE I31034	Nut M14
73	BIE G06199	Electrodes stirrup
74	BIE E10215	Electrodes
75	BIE C30368	Cable protection Ø12 mm
76	BIE G02080	H.T. Cable connect. L=1200 mm
77	BIE I40192	Micropipe L=250 mm 9.84"
79	BIE E50329-BR-VERDE	Photocell
79	BIE E50336	Phototransistor starting w/SN 21803501
80	BIE T20441-1	Pump Suntek AT2 45 BK 2S-120V-Includes valve & solenoid coil
81	BIE T20459	Solenoid coil AT2 45 BK 2S Suntek -120V
82	BIE T20130	Solenoid valve body torque Suntek
83	BIE I20115	Nipple FE 1/8" MM fitting
84	BIE E10513	Coupling K1
85	BIE E11233	Capacitor 20 μ F
86	BIE E10677-110	Motor 200W with capacitor - 120V 25uF
87	BIE G06200-9010	Support fan and motor
88	BIE C10328	Connection channel
89	BIE C30372	Cable protection Ø35 mm
90	BIE G06201-9010	Support fan and motor
91	BIE C10329	90°elbow connection
92	BIE T10262	Fan AP 160x55 F12,7
93	BIE C10326	Spiral fan housing
94	BIE G06202	Shutter for air regulation
95	BIE G06203	Air adjustment level
99	BIE G06204	Air adjustment protection
100	BIE E50327	Photoresistance protection
100	BIE E50327-30	Photoreistor support starting w/SN 21803501
101	BIE E20418	Stop button protection
102	BIE G06227	Fitting support
103	BIE G06406-9010	Switch Support
104	BIE E50441	200 Pa air switch
105	BIE I40335	Silicone pipe Ø4x8, 39"
106	BIE I31131	Conn. Straight Ø6
107	BIE T20241	OR KIToil filter
108	BIE T20242	Filter cartridge
109	BIE T20442	Solenoid valve cable
110	BIE E20406-1	Plastic profile
111	BIE E20627	Plate plug 4P + T
113	BIE G06418-9005	Lifting frame
114	BIE G06315-9005	Body support
115	BIE G06316-9005	Front protection
116	BIE C10558	Wheel Ø 409 - Ø 26 mm
117	BIE G06419-9005	Wheel axle Ø25
120	BIE G06208	Reinforcement plate
121	BIE G06461-9005	Support
122	BIE G06422	Reinforcement plate
123	BIE G06326-9005	Bracket
124	BIE G06317-9005	Tank structure
125	BIE G06424-9005	Panel DX
126	BIE G06425-9005	Panel SX
127	BIE G06423-9005	Handle
128	BIE M30001	Spring
129	BIE G06426	Plate
130	BIE C10710	Knurled wheel M8x25
131	BIE C10203	Handle
132	BIE I20613	Fitting
133	BIE I30115	Fitting
134	BIE M10246	Screw
135	BIE M21023	Aluminum washer

** E50329-BR-VERDE replaces E50329



**TROUBLESHOOTING
OBSERVED FAULTS, CAUSES AND REMEDIES**

<i>OBSERVED FAULT</i>	<i>CAUSE</i>	<i>REMEDY</i>	
• Motor does not start, no ignition	• No electrical current or main switch	• Check mains • Check proper positioning and functioning of switch • Check fuse	
	• Wrong setting of room thermostat	• Check correct setting of main switch(s) If thermostat, make sure selected temperature is higher than room temperature	
	• Thermostat or overheat limit	• Replace control device	
	• Electrical motor defective	• Replace electrical motor	
	• Red light on	• Push to reset 1 second Hold 3-5 seconds for diagnostic code	
	• Burned out capacitor	• Replace capacitor	
• Motor starts, no ignition or cuts out	• Not enough or no fuel at all at burner	• Check state of motor-pump plastic coupling • Check fuel line system including fuel filter for possible leaks • Clean or replace oil nozzle	
	• Air switch fault	• Remove ducting restrictions/check voltage at control board	
	• Flame control box defective	• Replace control box	
	• Photocell defective	• Clean or replace photocell Check resistance, if zero or infinite-replace	
	• Electric ignitor defective	• Check connection of H.T. leads to electrodes and transformer	• Check electrodes setting (see scheme "REGULATION OF ELECTRODES") pg. 6
		• Check electrodes for cleanliness	
		• Replace H.T. transformer	
• Solenoid defective	• Check electrical connection • Check thermostat LI • Clean or replace solenoid		
• Motor starts, heater emits smoke	• Not enough combustion air	• Make sure air inlet and outlet are free	
		• Check setting of combustion air flap	
		• Clean burner disc	
	• Not enough fuel at burner	• Check pump pressure	
		• Clean or replace fuel nozzle	
	• Too much fuel at burner	• Check pump pressure • Replace nozzle	
	• Air leaks in fuel circuit	• Check the seals on diesel filter	
• Fuel contaminated or contains water	• Drain fuel in tank with clean fuel • Clean oil filter		
• Too much combustion air	• Check setting of combustion air flap		
• Heater does not stop	• Solenoid defective	• Replace solenoid coil or complete solenoid	

For additional details see advanced troubleshooting (page 25).

ADVANCED TROUBLESHOOTING

Motor and transformer do not operate.

Causes:

1. Incorrect or low voltage supplied to the heater.
2. Fuse in heater is blown. (no green light)
3. Thermostat defective, or not turned up to call for heat.
4. Control board is defective.
5. Reset button has not been reset. (red light on)

Solutions:

1. Incorrect or low voltage supplied to the heater. Most indirect oil heaters require a minimum of 108 volts to operate properly. A multi-meter set to measure volts can be used to check the amount of voltage at the end of the extension cord(s). If the measured voltage is too low, the length of the extension cord (s) must be shortened or a thicker gauge extension cord must be used.
2. Fuse in heater is blown. Locate and remove the in-line fuse of the heater. Set a multi-meter to measure ohms of resistance. Place a multi-meter probe on each end of the fuse. The multi-meter should read zero ohms (continuity) or the fuse is blown. If a new fuse blows immediately, check for possible causes. Check for incorrect voltage to the heater. Make sure the total amperage draw of all equipment running on the circuit is not too great. If the supplied voltage and total amperage draw are correct, check the wiring in the heater for correctness and possible shorts.
3. Thermostat is defective or not turned up to call for heat. Turn the thermostat up to the highest possible setting and try to start the heater. Next set a multi-meter to measure voltage coming out of the thermostat. If approximately 120 volts is not measured, the thermostat is defective.
4. Control board is defective. Using a multi-meter set for volts, check the hot and neutral wires which bring voltage into the control board. If proper voltage is reaching the board then the control board is defective. Check fuse on control board.
5. Reset button has not been reset. Push the reset button and try to start the heater.

Motor does not start, but ignition spark is present

Causes:

1. Control board is defective.
2. Motor is defective.
3. Motor start capacitor is defective.
4. Fuel pump seized

Solutions:

1. Control board is defective. Locate the terminals of the control board that connect to the motor wires. Use a multi-meter set to read voltage and check for approximately 120 volts to the motor when the heater is turned on. If no voltage is observed the control board is defective. Check fuse on control board.
2. Motor is defective. If the control board and the motor start capacitor check ok and the fuel pump is not seized, the motor is defective.
3. Motor start capacitor is defective. The capacitor may be tested using a multi-meter set to the lowest possible ohm range. First "short" the capacitor by momentarily placing a screwdriver across the two capacitor terminals. Then place the multi-meter probes on the two capacitor terminals. The multi-meter should read close to zero ohms (continuity) first, then slowly move to infinity on the multi-meter. If not then the capacitor is defective.
4. Fuel pump seized. With the heater unplugged, stand behind the heater and attempt to turn the fan blade clockwise by hand. If the fan blade is difficult to turn, undo the connection between the motor shaft and the pump shaft. Attempt turning the fan blade again. If the motor now turns freely, the pump has seized up. If the fan blade is still difficult to turn, the motor is defective.

****NOTE: Top cover shell of heater needs to be attached during troubleshooting (will affect operation of airswitch and photocell).***

Motor runs, no visible ignition and heater reset (red light) comes on

Causes:

1. Fuel filter is dirty.
2. Spray nozzle clogged.
3. Air proving switch defective.
4. Air entering the fuel pump thru the inlet line.
5. Safety thermostat defective or tripped.
6. Fuel pump is defective/or broken pump coupling
7. Solenoid valve is defective.
8. Control board is defective.

Solutions:

1. Fuel filter dirty. Check the external and internal fuel filters and clean or replace as necessary. Most fuel pumps contain an internal fuel filter located where the inlet line enters the fuel pump.
2. Spray nozzle clogged. Remove and inspect the spray nozzle. Clean or replace as needed. Do not clean the nozzle orifice with anything metal as this may enlarge the orifice.
3. Air proving switch is defective. Try to start the heater without ducting. Indirect oil heaters have an air proving switch wired between the control board and the solenoid valve. The air proving switch is normally open and requires air from the turning fan blade to close the switch and send power to the solenoid valve. Set a multi-meter to measure voltage. With the fan blade turning, check for voltage coming out of the air proving switch to the solenoid valve. If no voltage is read, next check for voltage at the control board terminals out to the air proving switch. If voltage at the control board is read, the air proving switch is defective. If no voltage is read at the board, the control board is defective.
4. Air entering the fuel pump thru the fuel inlet line. If air enters the pump it will lose its prime and will not maintain adequate pump pressure. First make sure all fittings, including the fuel filter on the inlet line are tight. If you still suspect air is entering the pump, start eliminating portions of the inlet line until the air leak is found. Start this process at the fuel tank end of the inlet line. It may be necessary to draw fuel from a small container rather than the fuel tank.
5. Safety thermostat defective or tripped. Also called overheat switch. Some indirect oil heaters have a safety thermostat wired between the control board and the solenoid valve. If the heater becomes too hot this normally closed switch will open and interrupt power to the solenoid valve. Use a multi-meter set to measure ohms. Place the multi-meter probes on the two male terminals of the safety thermostat. If the multi-meter shows infinity (no continuity) the safety thermostat is defective. If the switch opens up before the heater becomes hot, the safety thermostat is defective.
6. Fuel pump is defective. The output pressure of the fuel pump can be checked by placing a high pressure fuel gauge into the gauge port of the fuel pump. Use a gauge with enough capacity to measure the high pressure your particular heater can produce. Use the adjustment on the pump to set the pump pressure to the manufacturer's specification. If you do not have a fuel gauge, you may slightly loosen the pump's output line connection and place a rag there. Run the heater briefly and see if fuel reaches the rag. If no fuel is pumped, check the connection between the motor and the fuel pump to make sure the motor can turn the pump. Also check the external and internal fuel filters for blockage, and clean or replace if necessary. The fuel pumps internal filter is usually located where the fuel inlet line enters the pump. Check to make sure motor is rotating pump.
7. Solenoid valve is defective. Call tech service for assistance.
8. Control board defective. Use a multi-meter set to measure voltage. Take a voltage reading on the control board terminals that send input power to the transformer. If proper voltage is not present, the control board is defective. Check fuse on control board.

Motor runs, fuel sprays, but no spark is observed

Causes:

1. Electrodes damaged or gapped incorrectly.
2. Transformer defective.
3. Control board defective.

Solutions:

1. Electrodes damaged or gapped incorrectly. Inspect the electrode tips for melting. Make sure there are no cracks in the porcelain insulation. Check the electrodes with the manufacturer's specifications for gapping and spacing. Adjust or replace the electrodes as needed.
2. Transformer defective. Transformers require a ground connection to function properly. Check the transformer's ground wire or mounting tabs for a good ground connection. Use a multi-meter set to measure voltage. Check the voltage in to the transformer from the control board for approximately 120 volts. Do not attempt to measure the transformer's output voltage with an ordinary multi-meter. The transformer may also be bench tested for proper output arc.
3. Control board defective. Use a multi-meter set to measure voltage. Take a voltage reading on the control board terminals that send input power to the transformer. If proper voltage is not present, the control board is defective. Check fuse on control board.

Motor runs, fuel sprays, spark is present, but heater will not ignite

Causes:

1. Pump pressure incorrect.
2. Electrodes damaged or gapped incorrectly.
3. Nozzle dirty or worn.
4. Air damper setting is incorrect.
5. Transformer output is weak.
6. Ducting is improper.
7. Venting is improper.
8. Fuel contains water or contaminants.

Solutions:

1. Pump pressure incorrect. Using a high pressure fuel gauge, check the output pressure of the fuel pump. If necessary, use the pump's adjustment to set the pump pressure to the manufacturer's specifications.
2. Electrodes damaged or gapped incorrectly. Inspect the electrode tips for melting. Make sure there are no cracks in the porcelain insulation. Check the electrodes with the manufacturer's specifications for gapping and spacing. Adjust or replace the electrodes as needed.
3. Nozzle dirty or worn. Clean the nozzle using compressed air. Never use anything metal to clean the nozzle as this may enlarge the orifice. With enough use, fuel traveling under high pressure thru the nozzle orifice can enlarge the orifice. This is especially true when diesel fuel is used. Clean or replace the nozzle as needed.
4. Air damper setting is incorrect. Use the manufacturer's specifications for the air damper setting and adjust as needed.
5. Transformer output is weak. Remove the transformer and perform a bench test.
6. Ducting is improper. Follow the manufacturer's recommendations concerning maximum duct length and diameter.
7. Venting is improper. Follow the manufacturer's guidelines for venting.
8. Fuel contains water or contaminants. Visually inspect the fuel in the tank for water bubbles or contaminants. Drain, flush, and re-fill tank as needed.

Heater ignites, runs less than one minute and shuts down

Causes:

1. Photocell is dirty, misaligned or defective.
2. Control board is defective.
3. Fuel pump defective.
4. Fuel filter dirty.

Solutions:

1. Photocell is dirty, misaligned or defective. Check that the photocell is aimed correctly and is free of dirt. If necessary, clean the photocell "eye" with a soft, dry cloth. If resistance is zero or infinite, photocell is defective (10K scale on multimeter).
2. Control board is defective. If the heater's spray and spark are correct, the photocell and control board must work together to recognize the combustion flame has become established. Therefore if a new photocell does not correct this symptom, the control board is defective.
3. Fuel pump is defective. If the fuel pump will not achieve or maintain proper output pressure, the fuel pump is defective. Check the pump's output pressure with a gauge.
4. Fuel filter dirty. Inspect the internal and external fuel filters and clean or replace as needed.

Heater ignites, runs several minutes, then shuts down.

Causes:

1. Fuel pump is defective.
2. Overheat thermostat is defective.
3. Ducting is improper.
4. Venting is improper.
5. Nozzle is dirty.
6. Fuel filter is dirty.
7. Control board is defective.
8. Fuel contains water or contaminants.
9. Solenoid valve is defective.

Solutions:

1. Fuel pump is defective. If the fuel pump will not achieve or maintain proper output pressure, the pump is defective. Check the fuel pump output pressure with a gauge.
2. Overheat thermostat is defective. Also called a safety thermostat or limit switch. Some heaters are equipped with this. Set a multi-meter to measure ohms of resistance. Perform this test immediately after the heater shuts down and the overheat thermostat is still hot. Place the multi-meter probes on the two male terminals of the safety thermostat. If the multi-meter reads infinity (no continuity) the safety thermostat is defective. Remember that if the heater is over firing due to high pump pressure, worn nozzle, or is improperly ducted or vented, the safety thermostat will heat enough to shut the heater off.
3. Ducting is improper. Always follow the manufacturer's recommendations regarding maximum duct length and diameter. Failure to do so can result in heat building up in the heater until the safety thermostat contacts open and shut the heater off.
4. Venting is improper. Follow the manufacturer's recommendations concerning proper venting. Failure to do so can result in heat building up in the heater until the safety thermostat contacts open and shut the heater off.

5. Nozzle is dirty. If dirt reaches the nozzle, the spray can be adversely affected and cause a shut down. If possible observe the spray pattern and clean the nozzle as needed.
6. Fuel filter dirty. Check the internal and external fuel filters. Clean or replace as needed.
7. Control board is defective. For the heater to function, the control board must send proper voltage to three components: motor, transformer and solenoid valve. Using a multi-meter set to measure voltage, check the appropriate control board terminals for proper voltage out to these three components. If proper voltage to any of these three components is not observed, the control board is defective.
8. Fuel contains water or contaminants. Visually inspect the fuel in the tank for water bubbles or contaminants. Drain, flush, and re-fill as needed.
9. Solenoid valve is defective. Use a multi-meter set to measure voltage. Check for proper voltage at the solenoid valve. If proper voltage is read and the solenoid valve will not stay open and allow fuel spray, the solenoid valve is defective.

Heater ignites, but combustion is poor or uneven

Causes:

1. Fuel pump pressure is incorrect.
2. Nozzle dirty or worn.
3. Electrodes damaged or gapped incorrectly.
4. Fuel filter is dirty.
5. Air damper setting incorrect.
6. Whirl disk dirty or mis-aligned.
7. Ducting is improper.
8. Venting is improper.
9. Fuel contains water or contaminants.

Solutions:

1. Fuel pump pressure is incorrect. The output pressure of the fuel pump can be checked by placing a high pressure fuel gauge into the gauge port of the fuel pump. Use a gauge with enough capacity to measure the high pressure your particular heater can produce. Use the adjustment on the pump to set the pump pressure to the manufacturer's specifications.
2. Nozzle dirty or worn. Clean the nozzle using compressed air. Never use anything metal to clean the nozzle as this may enlarge the orifice. With enough use, fuel traveling under high pressure thru the nozzle orifice can enlarge the orifice. This is especially true when diesel fuel is used. Clean or replace the nozzle as needed.
3. Electrodes damaged or gapped incorrectly. Inspect the electrode tips for melting. Make sure there are no cracks in the porcelain insulation. Check the electrodes with the manufacturer's specifications for gapping and spacing. Adjust or replace the electrodes as needed (page 5/17).
4. Fuel filter is dirty. Inspect the internal and external fuel filters and clean or replace as needed.
5. Air damper setting incorrect. Use the manufacturer's specifications for the air damper setting and adjust as needed. (see Diagram B, page 17)
6. Whirl disk dirty or mis-aligned. Inspect the whirl disk and clean if necessary. If the disk is warped or mis-aligned, replace or adjust as needed.
7. Ducting is improper. Follow the manufacturer's recommendations concerning maximum duct length and diameter.
8. Venting is improper. Follow the manufacturer's guidelines for venting.
9. Fuel contains water or contaminants. Visually inspect the fuel in the tank for water or contaminants. Drain, flush, and re-fill tank as needed.

Heater ignites but flame is excessive

Causes:

1. Fuel pump pressure is too high.
2. Nozzle is worn.
3. Incorrect fuel.

Solutions:

1. Fuel pump pressure is too high. Attach a high pressure fuel gauge to the fuel pump and check the pump pressure. Adjust the pressure to the manufacturer’s specifications with the adjustment on the fuel pump.
2. Nozzle is worn. With enough use, the impurities in the fuel traveling under high pressure thru the nozzle orifice can enlarge the orifice. This is especially true when diesel fuel is used. A worn nozzle can cause the heater to run “rich” and possibly over fire the heater enough to activate the safety thermostat and cause a shutdown. Replace after 400 hours of operation.
3. Incorrect fuel. Only use the manufacturer’s recommended fuels. Never use gasoline, paint thinner, solvents, or other flammable liquids. If you suspect the fuel is incorrect, drain, flush and re-fill the tank with proper fuel.

FUEL PUMP ADJUSTMENT

Model Heat Wagon	Type	Nozzle		Pump pressure [bar] / [psi]
		[GPH]	[°]	
HVF 110	Danfoss	0,55	80° W	13,5 / 196
HVF 210	Delavan	1.10	80° W	12 / 174
HVF 310	Delavan	1.50	80° W	2 Stage P1: 10/145 P2: 20 / 290 1 Stage 12 / 174
HVF 410	Delavan	2,00	80° W	P1: 160 P2: 218

1. DIAGNOSTICS

If the control unit is in lockout status, by keeping the reset push-button pressed for about 5 seconds, the diagnostics routine will be activated and the cause leading to the lockout condition will be displayed. Pressing the reset push-button again enables to reset the device and to terminate the diagnostics routine. The following table shows a description of the diagnostics messages provided by the red LED blinking:

No. blinks of red LED	Description
2	Flame failure at the end of TS
4	Extraneous light / Flame simulation at start-up
7	Flame failure in running status
8-14	Internal failure

FOR 2 RED BLINKS CAUSE MAY BE:

- No flame at 1st start up (review page 12 and 13)
- Other causes may be defective over heat limit switch (check for continuity)

FOR 4 RED BLINKS CAUSE MAY BE:

- Photocell senses light before start- up (make sure cover is on and photocell installed properly)

FOR 7 RED BLINKS CAUSE MAY BE:

- Out of fuel
- Filter or nozzle blocked
- Broken fuel line (intake sucking air)
- Bad photocell
- Overheat limit switch tripped

2. SIGNALLING DURING OPERATION

In the various operating conditions, the device can signal its operating status by means of a multicolour LED located on the on-board lockout signal. The meaning of the colours is the following:







	Green: Prepurge time (TP) – Ignition (TS) - Operating (RP)
	Orange: Cooling of the transformer
	Red: Lockout position (LO)
	Flashing Green: Stand-by position (SY)
	Flashing Orange: Stand-by position (SY) with presence of spurious flame
	Green + Flashing Orange: Prepurge time (TP) with presence of spurious flame

Fig. 6 – Meaning of LED signals

3. RESETTING THE CONTROL UNIT

When the control unit goes to non-volatile lockout, to reset the system press the reset push-button till the lockout signal turns off (< 5 seconds).

- Non-volatile lockout (manual reset), in order to reset the system, the reset button must be pressed (less than 5 seconds).
- Volatile lockout, turn selector switch to OFF position, hold reset button for a least one minute, red light should go out, let control board “reboot” for at least another minute before attempting to start again.



*342 N. Co. Rd. 400 East
Valparaiso, IN 46383
219-464-8818 • Fax 219-462-7985
www.heatwagon.com*

